

## **NOTICE OF GUIDANCE DOCUMENT**

Pursuant to Wis. Stat. § 227.112, the Wisconsin Department of Justice is hereby seeking comment on the following proposed guidance documents

### **Physical Evidence Handbook (9<sup>th</sup> Ed.)**

### **PUBLIC COMMENT AND DEADLINE FOR SUBMISSION**

Comments may be submitted to the Wisconsin Department of Justice until February 24, 2020, by emailing the agency contact person listed below.

### **AGENCY CONTACT PERSON**

Jody J. Schmelzer  
Assistant Attorney General  
[schmelzerjj@doj.state.wi.us](mailto:schmelzerjj@doj.state.wi.us)

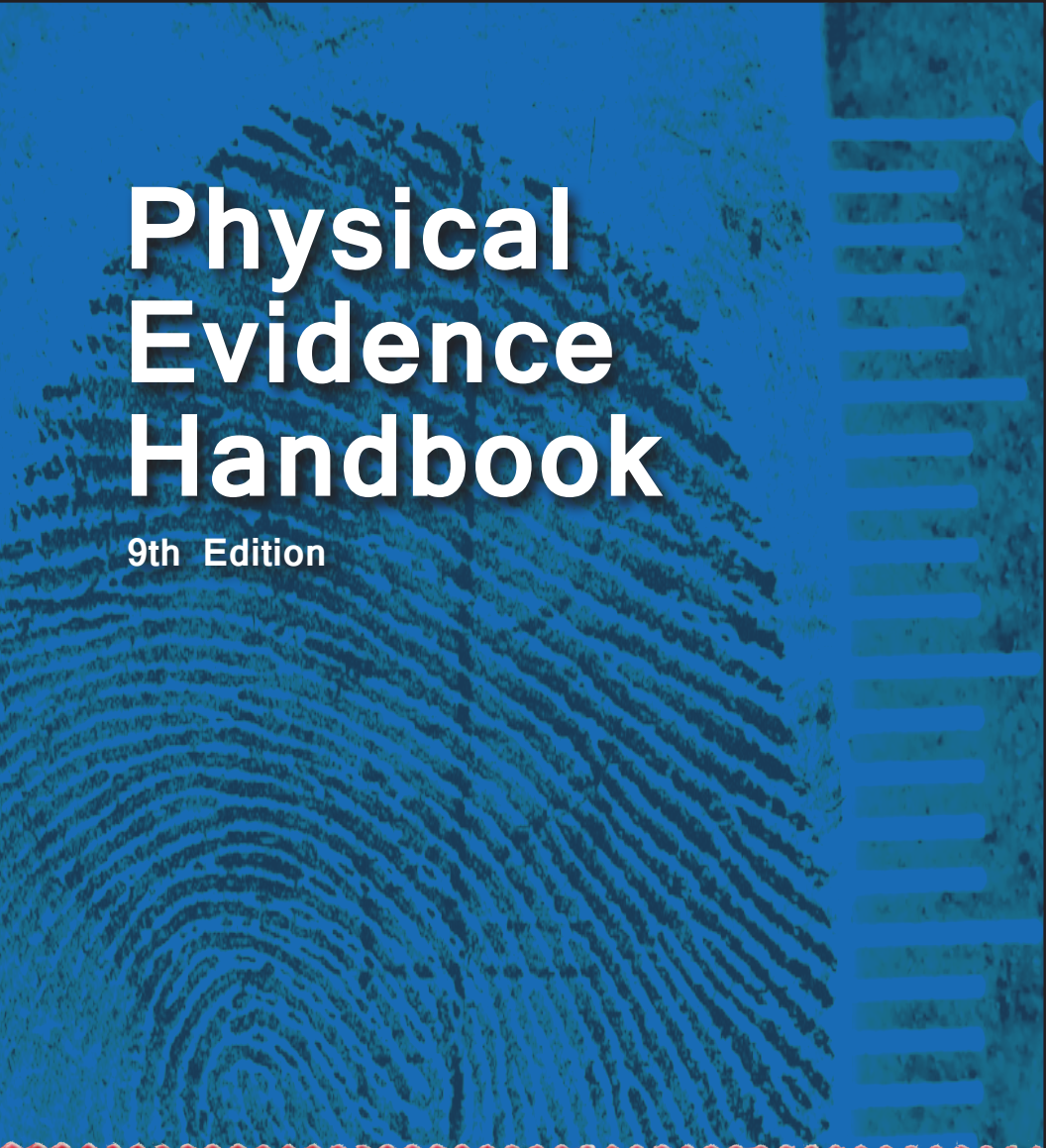

# Physical Evidence Handbook

9th Edition



# EVIDENCE

Wisconsin Department of Justice  
Crime Laboratory Bureau  
Brad Schimel, Attorney General

# Physical Evidence Handbook

9<sup>th</sup> Edition



**Wisconsin Department of Justice  
State Crime Laboratories**

**Brad Schimel, Attorney General**

Copyright© 2017 by the State of  
Wisconsin Department of Justice  
All rights reserved.

---

May not be reproduced in part or in whole in any form without  
the express permission of the Department of Justice.

---

First Edition – 1968  
Second Edition – 1973  
Third Edition – 1981  
Fourth Edition – 1987  
Fifth Edition – 1993  
Sixth Edition – 2001  
Seventh Edition – 2003  
Eighth Edition – 2009  
Ninth Edition – 2017

Published in the United States of America



# Table of Contents

Preface.....	i
Introduction .....	iii
1. Evidence Integrity .....	1
2. Forensic Photography .....	17
3. Video and Audio Recordings .....	41
4. Crime Scene Sketch .....	47
5. Bloodstain Pattern Analysis .....	59
6. DNA Evidence and Standards.....	61
7. Sexual Offenses .....	73
8. DNA Databank .....	79
9. Questioned Documents.....	87
10. Firearms and Ammunition .....	91
11. Footwear and Tire Examinations .....	101
12. Footwear and Tire Impressions .....	103
13. Latent Prints .....	119
14. Major Case Prints .....	131
15. Automated Fingerprint Identification System (AFIS) .....	141
16. Burglary.....	157
17. Building Materials .....	163
18. Glass.....	167
19. Tool Marks.....	171
20. Paints .....	175
21. Metals.....	179
22. Clothing and Fabrics.....	181
23. Hairs and Fibers .....	185
24. Woods and Sawdust.....	189
25. Fracture and Tear Matches.....	191
26. Vehicles.....	195
27. Autopsy .....	205
28. Identification of Unknown Deceased .....	213
29. Dental Identification of Human Remains.....	219
30. Toxicology.....	227
31. Poisoning.....	241
32. Controlled Substances.....	245

33. Arson ..... 257

34. Explosives, Bombs and Fireworks ..... 261

    Appendix A - Bloodborne PAtHogens..... 265

    Appendix B - Collection Kits..... 268

    Appendix C - Evidence Submission Guidelines ..... 272

Index..... 284



## Preface

Many changes have occurred in the Forensic Science community since last revision of this Physical Evidence Handbook in the field of Forensic Science. The release of the National Academy of Sciences report *Strengthening Forensic Science in the United States: A Path Forward*, a resulting emergence of the Organization of Scientific Area Committees (OSAC) made up of five Scientific Area Committees (SACs) which report to a Forensic Science Standards Board (FSSB) for Forensic Science under the development coordination of the National Institute of Standards and Technology (NIST), emerging technology in various fields such as new and innovative DNA technologies, imaging workstations incorporating comparative analysis software for forensics and law enforcement, and the President's Council of Advisors on Science and Technology report (PCAST), etc. All which are worthy of attention and discussion; however, the scope of this handbook does not allow attention to direct discussion of such occurrences except to potentially make reference as they relate to the physical evidence of forensic science that is the application of various sciences to law.

The need for proper recognition, collection, and preservation of physical evidence is apparent to all who are involved in the criminal justice system. Physical evidence can directly or indirectly lead to the resolution of a crime. Charging and prosecuting decisions may be affected by the quality of the physical evidence supporting the case. The United States and Wisconsin Supreme Court decisions have placed great emphasis upon physical evidence in criminal cases.

The Wisconsin State Crime Laboratory provides an important link between collection and court presentation of such evidence—most agencies within the state rely on the Laboratory for forensic examinations. It sometimes happens, however, that materials submitted to the Laboratory prove inadequate for proper analysis, or that improper collection or packaging methods destroy valuable evidence. It is unrealistic to expect that all submitters will know how to collect evidence in the

## ***Preface - Introduction***

manner required by the Laboratory, however, submitters should have at least general knowledge of proper techniques to guide them.

This handbook is offered in the belief that increased knowledge leads to understanding and that understanding leads to excellence. It was written to provide information regarding Laboratory requirements surrounding collection and preservation of physical evidence. This handbook is not intended to be a comprehensive treatment of all of the factors involved in criminal investigation.

Because the laws and legal precedents concerning collection of physical evidence are subject to change, it is impossible to give specific, up-to-date information on acceptable procedures. Therefore, it is imperative that during an investigation, close liaison is maintained between the prosecutor's office and persons responsible for the collection of physical evidence.

The staff of the Wisconsin State Crime Laboratory has revised and updated this 9th edition of the Handbook with intention that it will continue to be of great value to those who use it. Gratitude and acknowledgement is expressed to laboratory staff members for their many contributions to the work and to the Wisconsin State Crime Laboratory colleagues in other Divisions of the Department of Justice who have assisted in seeing this revision completed. Special acknowledgement is made to Crime Laboratory Bureau Technical Unit Leaders, the Wausau Forensic Imaging Unit, and management.

# Introduction

## Wisconsin State Crime Laboratory Bureau

The first Wisconsin State Crime Laboratory, located in Madison, was created by the Legislature in 1947. A second laboratory opened in the Milwaukee area in 1975. The Wausau Laboratory opened for business in 1991. Since the last edition of this handbook, the three Laboratories became the single State Crime Laboratory Bureau and continues to provide technical assistance in criminal matters when requested by authorized parties.

### Mission

*To promote excellence in analysis, training service to the community and our organization with integrity and uncompromising quality.*



### Vision

*To search for the truth through science and to lead and shape the advancement of forensic science.*

**Fig. Intro-1** Mission and Vision Statements

Contact information for the three crime laboratories within the Wisconsin State Crime Laboratory Bureau, Division of Law Enforcement Services, Department of Justice is as follows:

#### **State Crime Laboratory-Madison**

4626 University Avenue, Madison, WI 53705-2174  
Phone: (608) 266-2031, Fax: (608) 267-1303

#### **State Crime Laboratory-Milwaukee**

1578 South 11th Street, Milwaukee, WI 53204-2860  
Phone: (414) 382-7500, Fax: (414) 382-7507

#### **State Crime Laboratory-Wausau**

7100 Stewart Avenue, Wausau, WI 54401-8410  
Phone: (715) 845-8626, Fax: (715) 848-5833

Service map review provides guidance on the nearest and targeted lab to assist agency needs.

# Laboratory Service Areas

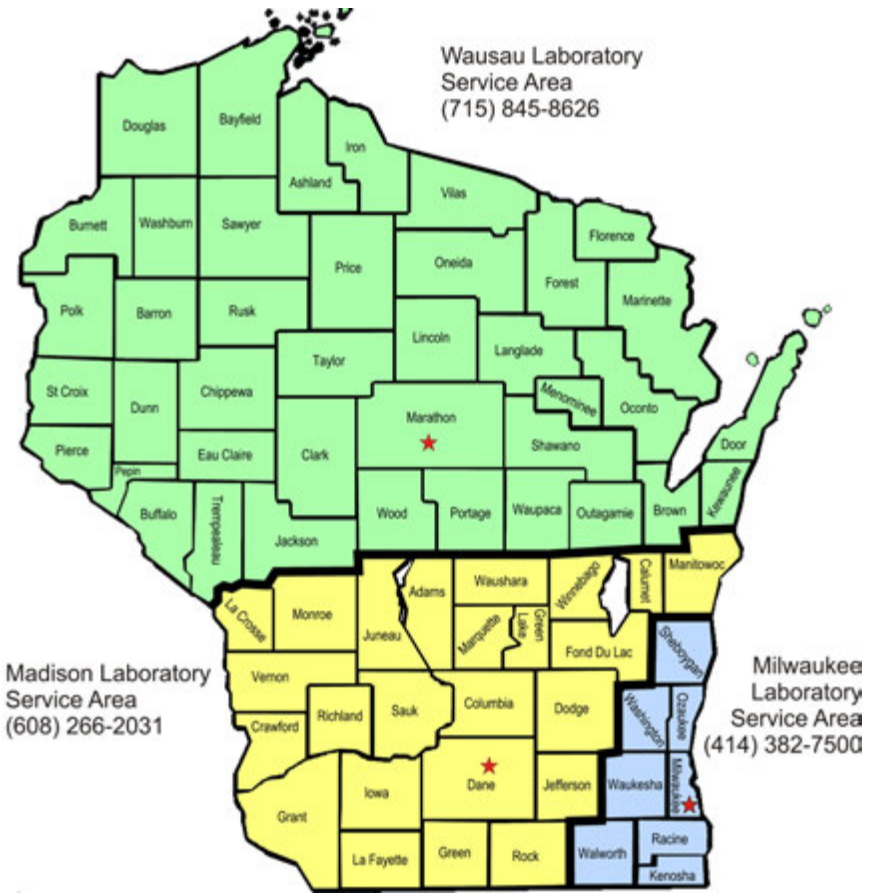

Fig. Intro-2 Laboratory Service Areas

## Forensic Analysis Units

Scientific analysis of physical evidence is conducted at the Laboratory<sup>1</sup> by specialized units grouped into three sections.

<sup>1</sup> The capitalized term “Laboratory” is used in this handbook to refer specifically to the Wisconsin State Crime Laboratory Bureau.

## Areas of Analysis:

### Chemistry

Controlled Substances Analyzes for presence (or absence) of controlled substances (i.e., cocaine, heroin, methamphetamine, LSD, and THC).

Toxicology Analyzes bodily specimens for presence of harmful substances or for criminally unlawful substances. Includes unknown causes of death and felony alcohols.

Trace Analyzes a broad spectrum of physical evidence including paint, glass, fibers, fire debris, explosives, plastics, lubricants, household and industrial chemicals, building materials, cosmetics, tapes, ropes and cordage, metals.

### Criminalistics

Firearms/ Toolmarks Examines firearms and tool marks; NIBIN entry of guns and unsolved cases; gunpowder pattern interpretation and serial numbers restoration.

Identification Examine for presence of friction ridge (“finger”) prints; AFIS; Footwear impressions. Compare prints/impressions to establish identity/origin.

Forensic Imaging Conduct photographic and digital imaging examinations and provides support for the analytical units.

Field Response Respond law enforcement agency calls for major crime scenes assistance (homicides and autopsies). Crime scene response, bloodstain pattern analysis, clandestine labs.

AFIS Specialists Operate State’s Automated Fingerprint Identification System (AFIS); provide identification information to all law enforcement agencies in Wisconsin. The central repository for fingerprint State arrestee identification records.

### DNA Analysis

DNA Analysis Analyze and compare biological material connected with crimes to characterize genetic information about the donor.

DNA Databank Maintain database of forensic evidence samples for comparisons against convicted offender and arrestee samples. Maintenance includes thorough examination of samples for deposit.

**Fig. Intro-3** Areas of Analysis

The Madison and Milwaukee laboratories are full service facilities while the Wausau laboratory supports drug analysis, fingerprint/footwear analysis, imaging, and field response.

## Computer Evidence

The Computer Forensics Unit of the Wisconsin Department of Justice is in the Division of Criminal Investigation that conducts forensic analysis of computer evidence. Information extracted from computer evidence can be a valuable component of an investigation. For questions involving computer evidence contact the Computer Forensics Unit by calling the DCI general contact number:

Wisconsin Department of Justice  
Division of Criminal Investigation  
(608)266-1671

## Procedure for Requesting Aid

The Laboratory is authorized to participate in a criminal investigation only at the request of authorized governmental officials (see table). Services of the Laboratory are available to the defendant in a felony action upon his or her request and with the approval of the presiding judge (Wis.Stat. §165. 79(1)). The Laboratory also cooperates with federal and other state agencies.

### Governmental Officials Authorized to Request Laboratory Assistance

[Wis. Stat. §165.75(3)(b)]

Sheriff	Chief of Police
Coroner	Attorney General
Medical Examiner	Governor
District Attorney	Head of any State Agency

**Fig. Intro-4** Authorized submitters to the Laboratory

The head of any Wisconsin State Department may request investigations. In such cases, the services provided by the Laboratory shall be limited to the fields of health, welfare, and law enforcement responsibility which has by statute been vested in the particular state department. Examples of such state departments include the Department of Natural Resources, the Department of Agriculture, the Department of Health and Family Services, and others.



When Laboratory assistance is desired, it is suggested that the district attorney of the appropriate county be advised that an investigation is being undertaken and the Laboratory's services are needed and requested. The Department is authorized by statute to decline to provide Laboratory service in any matter not involving a potential felony charge.

### **Services Not Offered**

The Laboratory no longer offers analytical services for tire impression evidence and questioned documents. Refer to the FBI for assistance. Guidance and procedures for collecting, preserving, packaging, and shipping evidence to the FBI may be found in the FBI Handbook of Forensic Services at <https://www.fbi.gov/file-repository/handbook-of-forensic-services-pdf.pdf/view>. The Laboratory does not offer bite mark examination.

### **Technical Support**

Regardless of case acceptance, the Laboratory is available for consultation. If in doubt, law enforcement officials are urged to communicate with the Laboratory about particular problems confronting them regarding physical evidence in their investigation. The Laboratory is open Monday through Friday, 7:45 AM to 4:30 PM, except holidays. Forensic Scientists are available 24 hours a day to answer questions concerning evidence recognition, collection, and preservation. Contact the laboratory in your service area. If unable to reach a Forensic Scientist or the Field Response Team after business hours, contact the Time Control Center at (608) 266-7633.

### **Field Services**

When requested by an authorized law enforcement official, the Laboratory provides field services to assist in processing crime scenes of major offenses. Mobile units are equipped to aid in the recognition, recovery, and preservation of physical materials which may have evidentiary value for transport to the Laboratory by an authorized submitter for processing. Laboratory personnel are not vested with power of arrest and, therefore, require that suitable law enforcement personnel be present to protect and assist Laboratory personnel when processing scenes for physical evidence.

The Laboratory provides field services in the following areas:

**Crime Scene Field Response Unit will assist law enforcement in processing suspicious death investigation**

**Bloodstain Analysis** Upon request, forensic scientists will respond to suspicious Pattern death investigations to document and analyze bloodstain patterns

**Clan Laboratory Chemist** Responds to clandestine laboratories in conjunction with the Division of Criminal Investigation (DCI)

**Autopsy** Madison Field Response Unit will assist at autopsies at the Madison VA Hospital

**Fig. Intro-5** Field services offered at the Crime Laboratory Bureau.

It is important that the crime scene is well protected and kept secured by law enforcement personnel when field assistance is requested. The requesting agency should assign the officer most familiar with the case to assume responsibility for the investigation. During the examination and processing of the crime scene, the officer who is assigned the case and other officers who have attended death investigation school and/or evidence technician courses should be made available to assist Laboratory personnel.



**Fig. Intro-6** Field Response Unit for the Milwaukee area laboratory.

Law enforcement agencies requesting assistance for crime scene investigations may contact the Laboratory at the following telephone numbers:

Agencies in the southern 24-county area served by the Madison Laboratory (608)266-2031 (24-hours a day)

Agencies in the southeastern 8 county area served by the Milwaukee Laboratory should contact the Madison Laboratory (608)266-2031 (24-hours a day)

Agencies in the northern 40-county area served by the Wausau Laboratory (715)845-8626 (24-hours a day)

If unable to reach any of the Laboratories at any time call the Time Control Center (608)266-7633



**Fig. Intro-7** Field Response Units for the Wausau area laboratory.

## **Evidence Submission Guidelines**

The Laboratory sets forth submission guidelines in partnership with customers for submission of the most probable forensic evidence first, rather than sending in all evidence in the beginning. This helps to provide investigative results in a more timely fashion.

See Appendix C.

## **Informational and Training Services**

The Laboratory presents training programs and seminars throughout the state for law enforcement, professional, and medical groups. Special training sessions for law enforcement officers may be held at the local level when deemed feasible. Requests for training by Laboratory personnel should be made through the Training Coordinator at the Madison Laboratory.

Special articles are written by the Laboratory staff when warranted. Often these articles appear in the Law Enforcement Bulletin, published by the Wisconsin Department of Justice.

If you are interested in receiving a subscription, contact the Division of Law Enforcement Services at (608)266-7751. Ask to speak with the Bulletin Editor.

District attorneys, coroners, sheriffs, chiefs of police, and members of their staffs are invited to visit our Laboratories for an informational tour when in Madison, Milwaukee, or Wausau. If desired and if advance arrangements are made, the staff is available to explain and demonstrate some of the scientific methods used in collecting, preserving, and processing evidence. Laboratory tours are limited to law enforcement personnel and to technical and professional groups by prior arrangement.

## **Court Presentation of Findings**

In addition to returning a written report of scientific findings, staff members are available to appear in courts of law as expert witnesses. At preliminary hearings, a forensic scientist's report can stand in place of an actual appearance. Wisconsin Statutes §970.03 (12)(b) reads, in part:

At any preliminary examination, a report of one of the crime laboratory's ... findings with reference to ... the evidence submitted, certified as correct by the attorney general ... or a person designated by ... them, shall, when offered by the state or the accused, be received as evidence ... The expert who made the findings need not be called as a witness.

A pretrial conference between the expert who conducted the examination and the prosecutor assigned the case, or with the defense attorney (if the expert is to appear as a witness for the defense) is recommended in all cases where expert testimony by a forensic scientist is presented at trial. Forensic scientists are available for consultation and assistance in preparation of those portions of the case involving their testimony.

# *The Physical Evidence Handbook*

*9<sup>th</sup> Edition*

**CRIME SCENE**

**EVIDENCE**



**EVIDENCE**

**EVIDENCE**

# Notes

# Evidence Integrity

**I**n any criminal investigation, the validity of information derived from examination of the physical evidence depends entirely upon the care with which the evidence has been protected from contamination. In other words, if the evidence has been improperly collected, handled, or stored, its value may be destroyed and no amount of laboratory work will be of assistance. Therefore, it is important that items of evidence be collected, handled, and stored in a way that will ensure their integrity. In doing so, the likelihood is increased that useful information can be extracted by examination and that the item will be considered admissible in court proceedings.

## I. Preserving the Crime Scene

The first officer at the scene of a crime has several immediate responsibilities. Among these duties is preserving the integrity of the scene by preventing the destruction of potential evidence that may lead to the resolution of the crime. To accomplish this responsibility, the first officer at the scene should consider the following:

- A.** As you near the scene, take note of persons and vehicles in the general area.
- B.** Attempt to obtain identification of any persons leaving the scene.
- C.** Limit access to the scene.
- D.** Note your route through a scene as you “clear” the scene.
- E.** Remove or isolate persons present at the scene - victims or witnesses - so that they do not purposely or inadvertently alter or destroy evidence. Instruct them not to discuss the events.
- F.** Every attempt should be made to exclude official “sightseers” by explaining the potential consequences of disturbing the scene.
- G.** Maintain a crime scene log in which the name, department, arrival and departure of each person at the scene is recorded. Note who has been inside the scene perimeter (EMS, fire department, etc.).

# Evidence Integrity 1

- H. Use a camera to document the scene as it was initially found.
- I. Record any changes to the scene by your actions or those of emergency personnel.
- J. Make note of the following but do not move or pick up anything:
  1. Doors and windows - opened, closed, locked?
  2. Lights, TV's or radios – on or off? Which ones?
  3. Odors (cleaning solutions, cigarette smoke, perfume, etc.) in the air?
  4. Items out of place?
  5. Condition of body?
- K. Attempt to “freeze” the scene as closely as possible to the condition in which it was found to minimize the destruction of evidence.
  1. Protect the perpetrator’s suspected routes of entry and exit. If possible use another entrance to the scene to avoid destroying possible latent footwear and fingerprint impressions.
  2. Protect evidence (such as footwear and tire impressions, biological and trace evidence) from inclement weather.
  3. Wear gloves and, if necessary, shoe covers when entering the scene. (Shoe covers should be worn at scenes where biological and trace evidence and latent footwear impressions may be important.)
- L. Collect victim/suspect clothing including footwear. If the victim’s clothing is removed at the scene by emergency personnel, advise them not to cut through holes in the clothing.
- M. Record any observations of the suspect(s). Any injuries? Any bloodstains on hands or clothing? Condition?

## II. Processing the Crime Scene

Processing of a crime scene should begin with an initial assessment. This assessment will help to formulate a systematic plan for the recognition, collection and preservation of physical evidence at the scene. Conduct a walkthrough of the scene with an officer well-informed of any actions that have occurred at the scene. As you conduct this assessment note the following:



- A. Potential evidence along the perpetrator's suspected routes of entry and exit.
- B. Is there evidence of forced entry? Toolmark impressions?
- C. What items have been disturbed or are out of place? Is there evidence of a struggle? Ransacking?
- D. Any potential bloodstains on walls, floors, or items.
- E. Possible weapon. Firearm? Knife? Blunt object?
- F. Footwear or fingerprint impressions in dust on hard surfaces. Use a flashlight with oblique lighting to reveal this evidence.
- G. What areas should be processed first to limit loss due to inclement weather or chance of contamination?
- H. What will need to be photographed? Sketched? Videotaped?
- I. How the search should be conducted.
- J. What evidence collection kits are needed? What additional resources?

After the initial assessment, processing of the crime scene can begin. This processing includes note taking, photography and videotaping (see Chapter 2), crime scene diagrams (see Chapter 4) and evidence collection. This handbook includes collection methods of various items of evidence that may be encountered at the scene. Appendix B in this handbook lists evidence collection kits that a law enforcement agency might want to consider creating for crime scene processing. **If an investigator is uncertain as to how to collect a certain piece of evidence, contact the Crime Laboratory for specific instructions.**

Make sure while processing the scene, appropriate personal protective equipment is worn (See Appendix A - Bloodborne Pathogens). Practice universal precautions (assume all biological samples are contagious). Change gloves often especially between items collected for DNA evidence. Wear booties at scenes to protect your footwear from biological materials and to prevent contaminating the scene.

If the crime scene involves a death investigation, do not remove the victim(s) until the route of removal and the area around the body have been processed to avoid contamination and destruc-

tion of evidence. Bag the victim's hands to preserve any evidence that may be trapped under the fingernails. The body must be wrapped in a new sheet and placed in a sealed body bag. An autopsy of a suspicious death should be conducted by a qualified forensic pathologist.

**When submitting evidence to the Laboratory, determine the most probative pieces of evidence to prioritize analysis. Evidence Submission Guidelines are available to submitters (See Appendix C) for assistance in prioritizing evidence for analysis. Laboratory staff are available if further assistance is required.**

## III. Collection of Evidence

It is important to properly collect, seal and identify items of evidence and maintain a proper chain of custody for two reasons. First, you must be able to prove that the item introduced in court is the same item that was collected at the scene. Second, you must ensure that the item is not altered or contaminated between the time it was collected and the time it was examined forensically or entered as evidence. These objectives are best achieved by proper packaging and sealing of evidence and maintaining a proper chain of custody.

### Packaging

Packaging materials should protect the item from contamination, tampering, or alteration. Packaging materials should not cause deterioration. For instance, articles of clothing should not be packaged in material that traps moisture. Items that might contain residual moisture should be packaged using a material that allows moisture to pass through - paper or cardboard. (**Note:** items for DNA examination should **always** be packaged in paper or cardboard, even if they appear dry.)

Unless an item of evidence is a liquid sample, items that are wet should be allowed to dry before being packaged and then packaged in paper or cardboard. There are occasions when a vapor-tight barrier is required. One example is when flammable liquid vapors are sought in fire debris. Such an item must be

packaged in a vapor-tight container.

Another way that packaging could contribute to deterioration is through abrading the surface of the item, thereby removing surface deposits. For instance, fingerprints can be obliterated by friction between the container and the item. Also, markings on lead bullets can be altered if packaged improperly.

*Only new, unused materials should be used to package evidence.* If the packaging has been previously used, trace evidence can be imparted to the item, negating the value of some examinations. Common packaging materials include paper, cardboard, plastic, metal cans and glass.

**Paper.** Paper goods are appropriate packaging for many different types of items. Paper is porous—it allows water vapor to escape. As a result, it is the packaging of choice for items which may contain residual moisture (unless it is important that the vapors be trapped). Clothing and other cloth items which are to be examined for DNA evidence should always be packaged in paper; moisture can lead to the destruction of DNA samples. Plant materials, such as marijuana or mushrooms which are confiscated fresh, should be thoroughly dried before submission to the Laboratory. When stored in plastic, plant material will mold, or, with enough time elapsed, may decompose into a moldy ooze (see Chapter 32, Controlled Substances).

Paper is also more appropriate than plastic for very small samples such as hairs, paint chips, and other small items. Surface treatments and static electricity may cause trace evidence to cling to plastic. This is not as great a problem with paper. The primary concern when using paper with trace samples is that the paper is securely folded and sealed so that the sample cannot escape through an opening.

*Bags.* Paper bags come in many sizes. Bags are a good choice for bulky items. Choose a bag that is sized to the item – don't use a full-size grocery bag to collect a wrist watch or a paint chip. Bags may leak at the seams and corners, and may not be suitable for powdery evidence unless all possible openings are taped.

**Envelopes.** Envelopes also come in a variety of sizes. Manila “coin envelopes” are good for small samples. Letter-size envelopes work well for many items. Large manila envelopes can be useful for larger moderately heavy items. Some manila envelopes designed to hold evidence are constructed with a clear acetate window which allows the contents to be viewed while retaining the breathability of paper. Like paper bags, envelopes may leak at the seams and may not be suitable for powdery evidence unless the seams are taped.



**Fig. 1-1** Choose the best size and type of packaging for your item given the wide variety of packaging and sizes available.

**Cardboard Boxes.** Large cardboard boxes work well for heavy or bulky items. Unless they have a waxy finish, cardboard shares paper’s porous nature and is a good choice for items that might contain residual moisture and for DNA samples. Cardboard boxes should not be used for trace evidence or when the item is to be examined for trace evidence. Small “slide boxes” are useful for samples such as bullets and bullet fragments. Various companies carry cardboard boxes for packaging weapons including knives and hand and long guns.



**Fig. 1-2** Examples of various cardboard boxes available including slide boxes, swab boxes and a box for securing a handgun or knife. Cardboard boxes

**Glass vials and jars.** Glass vials and jars are useful for liquid samples: blood, alcohol, flammable liquids, water and so forth. Blood samples should be collected by following instructions contained in Handbook chapters on Toxicology, DNA samples and Autopsy. The vial or jar must have a tight-fitting top and must be protected from breakage once collected.



**Fig. 1-3** Glass vials are available from hospital and scientific supply outlets. Smaller glass vials can be packaged within Nalgene bottles for protection. Use a clean, new pipette to transfer liquids to glass vials. In the case of glass pipettes, use a rubber bulb or other device designed for the purpose of providing suction. **Never** use your mouth—the practice is dangerous and may contaminate the sample.

**Plastic.** Plastic has several obvious advantages: it has great strength for its weight and transparent plastic allows inspection of the contents. There are several disadvantages which must be recognized, however. First, water vapor does not freely pass through plastic. Most evidence is adversely affected by prolonged exposure to water: steel will rust, cardboard or paper may decompose, biological materials (blood and semen stains) are destroyed, natural clothing materials (leather, wool, cotton) can mold and degrade. Some gaseous materials and vapors, depending on the plastic's moisture vapor transport rate (MVTR), can pass through semipermeable plastic and therefore may allow sought-after samples to escape. See the section, "Metal cans," for further details. Plastic is acceptable for items that you are certain are dry, especially plastics, paper, drug powders and tablets, etc.

Plastic sharps containers are available in a variety of sizes. Hypodermic needles must be packaged in a sharps container before submission to the Laboratory. Knives must be packaged in a sharps container or secured within a cardboard box. Consideration should be taken when deciding what packaging to use. If DNA testing is requested, secure the knife in a cardboard box and not a plastic sharps container.

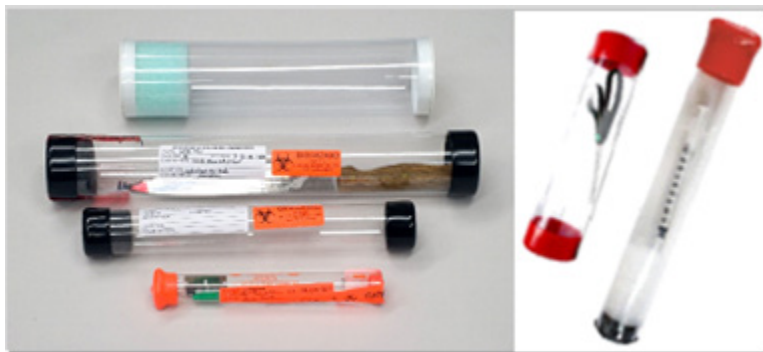

**Fig. 1-4** Examples of plastic sharps containers. Do not package knives in plastic containers if DNA testing is requested.

**Metal cans.** New, clean, unlined paint cans are ideal for storing non-biological samples that could evaporate. The most common examples are flammable liquid accelerants found in fire debris (e.g., gasoline, charcoal lighter fluid, etc.). A previously used can is not acceptable; paints contain solvents that are similar to an arsonist's accelerants. For the same reason, you should never reuse any evidence packaging materials, including cans. As indicated above, plastic allows hydrocarbon vapors to escape. Plastic may also be attacked and destroyed by high concentrations of vapors. **For these reasons, volatile samples should only be stored in metal and never in plastic.**

This general discussion is intended to give guidance in situations where specific instructions are not provided elsewhere in the Handbook. Consult chapters dealing with specific types of cases or evidence and if provided, follow instructions.

## Sealing

Evidence received by the Laboratory must be properly sealed. A proper seal provides proof that an item has not been accessed and therefore could not have been altered or contaminated during storage or transport. Nothing can be added or removed from a properly sealed package. The primary requisite of a good seal is that if it is tampered with, the tampering can be detected. There are many recognized sealing methods and a number are discussed below. All are used by the Laboratory. Methods of

sealing evidence include heat sealing in plastic, tapes, tamper-proof tapes, tamper-proof adhesive strips, or a combination of these methods.

**Tape.** Cellophane or cloth tape can provide a tamper-evident seal on some surfaces. However, tape on plastic does not provide an acceptable seal because it can be easily removed and replaced. The security of this method is improved by use of tapes with organizational names printed on them (thereby limiting the number of persons who could reseal the item). Use an indelible pen to **write your initials across the junction of the tape and the container**. If disturbed, it will be nearly impossible to reposition the tape so that it precisely matches.



**Fig. 1-5** Close the opening of the container by folding over the opening more than once. Use an indelible pen to write the sealer's initials across the junction of the tape with the container.

**Tamper-evident tapes.** Tamper-evident tapes are destroyed by efforts to remove them. Traditionally, the security feature was created by a combination of a tenacious adhesive and a low tensile strength backing. Some new tapes change color or have words develop when disturbed. The tapes come both in long rolls and in short, individual strips.

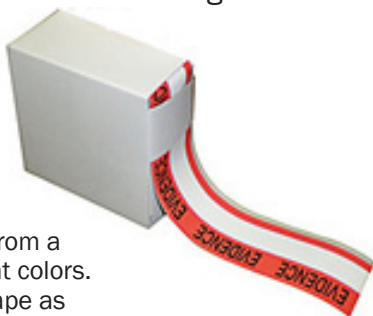

**Fig. 1-6** Tamper-evident tape is available from a number of suppliers and in several different colors. Your agency's name can be added to the tape as an additional identifier.

These tapes are advertised as providing tamper-evident seals on all surfaces. In reality, some brands of tape can be removed from plastic bags without evidence of tampering. Always check for permanence on an identical test object before using a particular tape. If the brand of tape or packaging is changed, retest.



# Evidence Integrity 1

One advantage of tamper-proof tapes is that they are designed to shred or tear when pulled or stressed. This advantage is a potential disadvantage, however, if a mechanically strong joint is required. Unless somehow reinforced, the tape may spontaneously shred if stressed. When the tape joint may be strained, use another method to secure the joint and then use tamper-evident tape across the joint. Some tamper-evident tapes will not adhere under cold conditions.

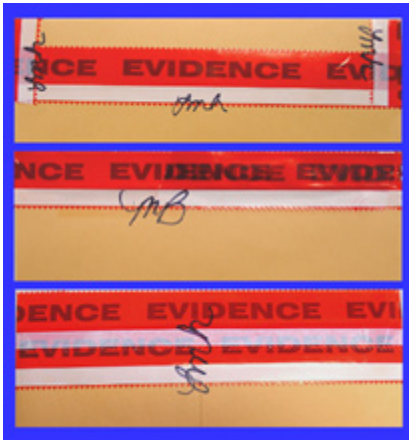
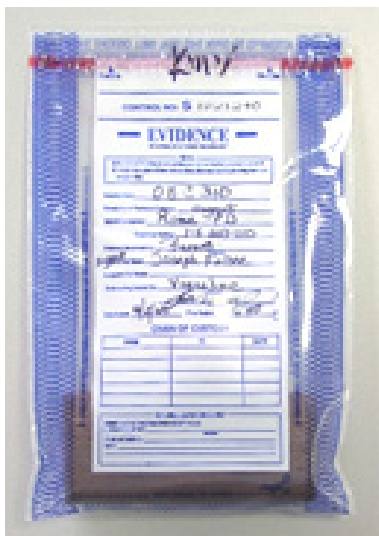

**Fig. 1-7** Use an indelible pen to write the sealer's initials across the tape. Make sure the sides as well as the bottom of the flap of the envelope are covered with tape to prevent anything from being added to or escaping from the envelope. The examples illustrate the flap folded inside or outside the envelope and taped with one or multiple strips of evidence tape. Always check the manufacturer's seal on the packaging to ensure that it is adequate.

**Tamper-evident adhesive strip.** Tamper-evident adhesive strips attached to plastic bags are a quick and easy method of sealing plastic bags. Remove the plastic protective cover from the adhesive and either squeeze the sides of the plastic bag together or on some bags fold the plastic flap over the adhesive strip and squeeze together. **Write your initials on the plastic bag directly over the adhesive seal.** Any attempt to disturb the seal results in distortion of the plastic bag and/or the initials.

**Staples.** Stapling, by itself, is not an acceptable method to seal evidence nor is it a preferred method to seal evidence. However, it can be used in conjunction with other sealing materials. Be aware, exposed staples can present a sharps hazard. **If staples are used they must be covered by tape.**





**Fig. 1-8** Use an indelible pen to write the sealer's initials on the plastic bag over the adhesive seal.

**Heat sealing.** The heat sealing method partially melts the plastic packaging and fuses it together. Some sealers emboss an identifiable mark into the seal. Use an indelible marker to **write your initials across the seal**. These markings provide evidence that the package was not opened and then resealed.



**Fig. 1-9** Several different types of plastics can be used with heat sealers, but each requires a different time/temperature combination. Make sure that you sufficiently heat the plastic to ensure the halves are fused together. Also pictured are commercial heat sealers. The heat sealer pictured embosses an identifiable mark into the seal.

**Fig. 1-10** Use an indelible pen to write your initials across the heat seal to authenticate it.

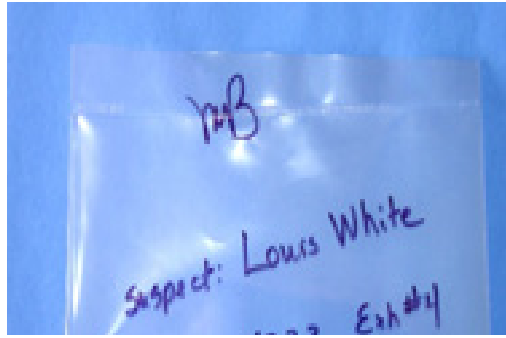

## Chain of Custody

The chain of custody is a record that documents every person that had custody and control of an item from the time it was collected until its introduction into court. It allows the courts to question all persons who possessed an item regarding their handling procedures and the actions they took.

The importance of a properly documented chain of custody cannot be overemphasized. The chain is often closely scrutinized. Evidence is challenged and sometimes rejected because of improper handling or documentation. Thus it is extremely important that proper methods be used in collecting, preserving, and documenting physical evidence.

The chain should be no longer than necessary. Ideally, it should include only:

- A. The investigator who recovers the evidence.
- B. The departmental evidence custodian (in cases when the item is not immediately transported to the Laboratory by the recovering investigator).
- C. The person who transports it to the Laboratory (if possible, one of the two preceding individuals).
- D. The person (normally the forensic program technician) who receives the evidence at the Laboratory.
- E. The Laboratory scientist who examines the evidence.
- F. The person that retrieves it from the Laboratory (if possible, one of the first two individuals).

## Transmittal of Criminal Evidence form

When submitting a new case or additional items for a case already submitted, a Transmittal of Criminal Evidence form must accompany the evidence (Fig. 1-11). This form supplies important details that are needed for Crime Laboratory record management. It also ensures that reports of analysis will be associated with the correct offense. If your agency does not have these forms or if you have any questions about proper completion, contact the Laboratory in your service area. An electronic version of the Transmittal of Criminal Evidence form is available upon request from the Laboratory in your service area and can be found on the Wisconsin law enforcement website [www.wilenet.org](http://www.wilenet.org).

Each offense should be submitted as a separate case. For instance, if fingerprints were found at three businesses burglarized on the same night in the same strip mall, each burglary could result in a separate criminal count. Therefore, each incident should be submitted on a separate form. In a drug case, if more than one buy/deal occurs involving the same suspect on the same day, the Laboratory considers **each** buy/deal a **separate** case which must be submitted on a **separate** transmittal form.

Make sure all entries are legibly recorded. Hand printing or type-writing is preferred. If there are special instructions, note them on the Transmittal form or include them in a letter in the same envelope.

### Information to be supplied includes:

1. **Submitting Agency.** Name of agency submitting case (Police Department, Sheriff's Office, MEG Unit, etc.)
2. **Submitting Agency Case Number.** Identical agency case number as shown on the evidence.
3. **City of Agency.** Municipality where agency is located.
4. **County of Agency.** County where agency is located.
5. **Date Transmitted.** Date case is mailed or transported to Lab.

6. **Offense Committed in City/Town/Village.** If known.
7. **County of Offense.** List only one county.
8. **Offense Date.** Only one incident per transmittal form. Must be one specific date, not a general time frame.
9. **Criminal Offense.** List all charge(s). Be specific. In drug cases, this is typically possession, possession with intent, delivery, manufacturing, etc. In cases such as arson, burglary, or theft, be sure to indicate the type of property burned, burglarized, or stolen.
10. **Trial Date.** Date of jury trial, if known.
11. **Victim(s).** Victim(s) of the crime. In drug cases, there are usually no victims. In the case of multiple burglaries, each burglary is a separate case even though the same suspect(s) may be involved. Each victim must be listed on a separate transmittal form. If a business is involved, include name of business, owner and any employees involved; list the cashier in armed robbery, etc.
12. **Suspect(s).** All suspect(s) in the crime, whether or not charged.
13. **Sex/Race.** Sex and race of victim(s) and suspect(s). This information is necessary in sexual assault cases for both victim and suspect.
14. **Age/Date of Birth.** Age and date of birth of victim(s) and suspect(s).
15. **Agency Exhibit Number.** If submitting agency has an exhibit number, item number or inventory number for the piece of evidence, it may be listed here and must match the exhibit number shown on the evidence.
16. **Number of Items.** Number of pieces of evidence being submitted under your item number or inventory number.
17. **Item Description and Source.** Brief description of evidence and the analysis requested.
18. **Full Name & Title of Submitting Officer.** Full, printed name of officer submitting case. (No initials or nick names —



### Packaging Checklist

Before shipping evidence ask yourself:

Has evidence been properly collected, preserved, and sealed for submission to the Laboratory (heat seals marked with the sealer's initials, all tape seals marked with the sealer's initials across the junction of the tape ends?)

Has evidence, to include fingerprint cards, been properly sealed?

Has evidence been properly packaged for shipping to the Laboratory?

Has Transmittal of Criminal Evidence form been properly completed?

Has Transmittal of Criminal Evidence form been put in an envelope attached to the **outside** of the package?

When using registered mail, the edges of the envelope must be completely covered with brown paper tape.

# Forensic Photography

*E*vidence photography, videography and other evolving multimedia technologies are indispensable to the evaluation, interpretation and presentation of physical evidence in court. Evidence photographs, diagrams, videos and other media must be of consistently high quality as well as fair and accurate representations of the depicted subject matter. The following recommendations have been compiled to produce photographs that meet these recommendations.

**DISCLAIMER:** The mention and/or use of any film, software, hardware, digital camera or other device is based on what was readily available for illustration purposes and does not constitute an endorsement or recommendation for any of these items.

## Services Provided by the Laboratory

The Forensic Imaging Unit provides analysis of photographic materials and other multimedia evidence using photographic and electronic imaging techniques. The analysis and support services provided to submitters include:

- date of manufacture of Polaroid photographs
- determination of which film camera was used
- determination of which negative was printed
- comparison of objects such as clothing, vehicles, buildings and weapons to photographs, electronic images or video images
- forensic video analysis
- demonstrative displays and video for court
- photography of bite marks and other injuries
- photography of vehicles and other physical evidence submitted to the Laboratory

Requests for photography, multimedia analysis and support services should be directed to the Forensic Imaging Unit of the laboratory serving your area.

## Photographic Procedures and Techniques

### I. Digital Imaging Issues

#### Admissibility and Chain of Custody

The legal requirements for the admissibility of digital photographs as evidence in court are the same as for film. Digital photography and digital image enhancement are accepted as a scientifically valid method of photographing objects as documented in Resolution 97-9 of the International Association for Identification.

Chain of custody requirements are the same for both film and digital photographs.

- **When photographs are taken to document what a witness observed, no chain of custody is required.**
- **If the photographs were seized as physical evidence, they must be store in the same manner as other physical evidence and a chain of custody must be maintained.**

#### Digital to Film Resolution Equivalents

There are wide variations in published tables that list the digital camera megapixel equivalent to film. The following equivalent in resolution (ability to record fine details) between digital and film photography is based on footwear impression photography research conducted by the Institute for Forensic Imaging which found that digital cameras in the range of 8 to 14 megapixels can record the same level of fine details in a footwear impression as recorded on a 35mm negative.

**Table 2-1 Digital Equivalent to Film**

Film Size	Digital Camera Resolution
35 mm	8 to 14 megapixels
120 medium format	25 to 40 megapixels
4x5" large format	116 to 174 megapixels

**NOTE:** This table is based in part on footwear impression photography research conducted by the Institute for Forensic Imaging. Table 2-2 lists the largest area that may be photographed based on



the resolution of the digital camera in order to provide enough fine detail for comparison purposes of latent prints. **Photographing a larger area than what is recommended will record less of the finer details needed and could reduce the usefulness of the digital photograph for comparison purposes.**

**Table 2-2 Digital Photography Requirements for Latent Prints**

Digital Camera Resolution	Largest Area that can be Photographed at 1,000 ppi
6 megapixels	2 X 3 inches
8 megapixels	3.25 X 2.5 inches
10 megapixels	2.6 X 3.9 inches
12 megapixels	2.85 X 4.25 inches
16 megapixels	3.3 X 5 inches
22 megapixels	4.1 X 5.4 inches
39 megapixels	5.4 X 7.2 inches

**NOTE:** This table is based on the SWGFAST standard of 1,000 ppi at 1X without resampling.

## Digital Photography File Formats

The **Camera RAW** file format is the preferred file format for digital photographs of latent prints, blood spatter, and footwear impressions that are submitted to the Laboratory for comparison purposes. The three disadvantages of the RAW file formats are:

- these are usually a proprietary file format,
- a RAW file format is a relatively large file, and
- few if any 1-hour photo labs can print these files without previously being converted to a current standard file format (tiff or jpeg).

Some cameras may allow you to simultaneously capture all images in both a RAW and JPEG file format.

The uncompressed **TIFF** file format is the next best alternative to the RAW file format in terms of overall quality. If submitting a processed TIFF file to the Laboratory, please be sure to also include an unprocessed copy of the original file. The two

## Forensic Photography (Imaging) 2

disadvantages of the TIFF file format is its relatively large file size and 1-hour photo labs may not be able to print these files.

The **JPEG** file format is the least desirable alternative to the RAW file format in terms of overall quality. Processed images should not be saved in a JPEG file format except for email purposes and for printing at 1-hour photo labs. If submitting a processed JPEG file to the Laboratory, please be sure to include an unprocessed copy of the original file. Also, the image quality should be set to the highest quality value. The main disadvantage of this file format is compression artifacting.

The **BMP** file format is normally used only for images to be imported into PowerPoint presentations and word processing documents. However, there are some digital CCTV systems that can only export individual still images in this file format.

All digital photography files must be submitted to the Laboratory in the same manner as physical evidence and copied onto physical digital media such as a CD or DVD. Electronic transmissions of these files will not be accepted. These files are treated by the Laboratory as evidence and an electronic submission does not provide an adequate chain of custody.

### Digital Photography Storage

If the original images are saved to a camera card, the original files should be downloaded to a computer hard drive and a backup copy should be made on a CD or DVD before the camera card is formatted and reused. If the original images are saved directly on a computer hard drive, follow the procedures for making a temporary backup on a CD or DVD.

A procedure should be developed for verifying the integrity of the copied files. This procedure can range from relying on the error checking in the computer operating system to the use of hash values such as MD-5.

The original files should be write-protected and only working copies of the original files should be processed. All files should be archived to a long term storage media such as archival grade

CDs and DVDs, pairs of external USB hard drives and redundant secure RAID servers.

The Scientific Working Group for Imaging Technologies (SWGIT) provides guidelines regarding storage and archiving of electronic and digital images. This information may be found at <http://www.swgit.org> and at the website of the International Association for Identification (IAI) <http://www.theiai.org>.

## II. Criminal Investigations

### General Guidelines

Upon arriving at the scene, the photographer should obtain all available information from either the first officer on the scene or the officer in charge. Using this information, the photographer should decide what photographs are needed and in which order they are to be produced. Do not move or disturb any evidence, bodies or items within the boundaries of the scene before they have been photographed, measured, sketched and released for collection by the officer in charge.

**Do not take a suspect or any item of physical evidence that has been moved or disturbed back to the scene for photographic or other purposes.**

Do not include yourself, other persons or any other object not part of the scene in the photographs. If positions of evidence need to be denoted in the photographs, take a photograph without any alterations and then retake the photograph with evidence markers in place. Be extremely careful not to disturb any items of evidence.

A good axiom to follow is: If in doubt, photograph it!

### Procedure

1. Determine a photographic starting point and progressively take photographs working your way into the scene. Photographs should maintain continuity between each other to present a “picture story” of the scene.
2. Photograph rooms from each corner with a minimum of four views. Additional photographs may be required of ceilings,

floors, doorways or hallways if not covered in the four minimum views.

3. Photograph bodies from all angles (be careful of distortion when photographing from head and feet) and overhead if possible. Do not disturb the body or clothing on the body to take photographs. The body will be photographed and examined at autopsy.
4. Scenes should be photographed keeping four basic views in mind:

**OVERALL VIEWS** show general locations, conditions and surroundings.

- Should be done at photographer's eye level unless duplicating a witness's point of view.
- A large outdoor scene, a scene involving several buildings or a route used may require aerial photographs.
- All scenes should have 360° overall views looking toward the scene and looking away from the scene. If possible, include identifiers like street numbers, fire numbers, permanent reference points, etc. Structures should have all sides, surrounding areas and adjacent buildings photographed.
- Interior overall views using the minimum four corner technique should be produced of all rooms connected with the scene.

**MEDIUM VIEWS** show a significant segment of the scene that has been previously recorded in the overall views. An example would be a body lying in the middle of the room. An overall view would show where the body was in relation to the room. A medium view would focus attention to the particulars of that body to give details like type of clothing, position of extremities, items close to the body, etc.

**CLOSE-UP VIEWS** are used to specifically show position and detail. This would include items such as a gun in relation to the hand, ejected cartridge cases, a bullet lodged in wall,

ligatures, gags, bindings, entry damage to door jam, etc. Close-ups of all evidence should be accomplished before collection, measuring and sketching take place.

**SPECIFIC EVIDENCE VIEWS** - these are detailed photographs documenting items of evidentiary value. Some examples include footwear impressions, fingerprints, footprints, processed fingerprints before lifting, tool and pry marks, fabric impressions, bite marks, serial numbers, etc.

- Can be very similar to a close-up view or may have been taken previously as a close-up view.
- Depending on the type of evidence, photographs may be more conveniently taken back at the agency after the item has been collected from the scene or autopsy.

5. As a final step, the photographer should confer with the officer in charge and describe all the photographs that were taken of the scene. The officer in charge may require additional photographs be taken.

## Photographic Notes

Generally, departmental policies will dictate what type of information the photographer needs to record. It is suggested that some type of “running” log be maintained. Log information that might be considered includes: frame number, photographer, date, case number, time started/ended, camera direction (use compass directions) and general description of item being photographed.

Do not mix cases on a roll of film or a digital camera card, and do not discard bad negatives or digital image files. Keep them as part of the photographic record of the scene and include them in the photo log.

With digital cameras, the date and time are usually found in the metadata. Therefore, it is important to routinely check the date and time settings on all digital cameras and on all computers used to process these files.

## III. Initial Record Photographs of Vehicles

A systematic approach is recommended when taking the initial record photographs of a vehicle. These photographs should include the exterior of the vehicle, all interior compartments, any obvious damage and anything commonly used to identify a specific vehicle such as the VIN number, the license plate number and any other serial numbered window stickers.



**Fig. 2-1** Begin at a logical point such as the front of the vehicle. When possible to back up far enough away from the vehicle, use a normal to short telephoto lens to obtain a normal looking photograph.



**Fig. 2-2** This is an example of the foreshortening that will occur when you have to use a wide-angle lens due to limited space such as in a small garage.



**Fig. 2-3** Include a standard color reference for color balancing purposes. Photograph the card under the same lighting conditions as the other objects to be photographed.



**Fig. 2-4** Before moving on, photograph the front license plate.



**Fig. 2-5** If the VIN plate is mounted on top of the dash, side light it with the flash inside the windshield. Because of contamination on the windshield, you may have to manually focus your lens. The condition of the windshield for Figure 2-6 was the same.



**Fig. 2-6** The flash was moved from inside to outside the windshield to side light the VIN number plate. Compared to Figure 2-5, this results in the dust and contamination on the windshield being more visible.

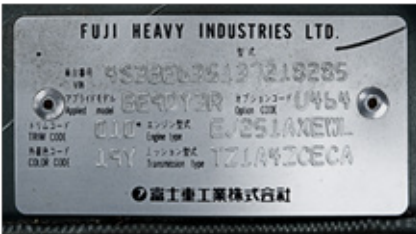

**Fig. 2-7** As an alternative to Figures 2-5 and 2-6, a data plate in the engine compartment with the VIN number on it may be photographed.

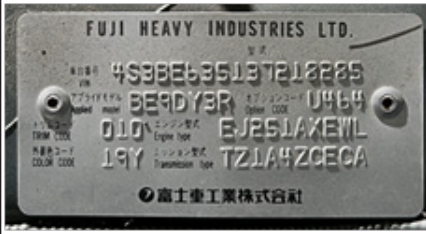

**Fig. 2-8** Side lighting with the flash off camera will usually work for raised letters and numbers.



**Fig. 2-9** As you walk around the vehicle, the next logical photograph is the overall view of the driver's side of the vehicle. As a general rule, if you have to use a shutter speed slower than 1/125 second and for all close-up photographs, you should use a tripod.





**Fig. 2-10** This photograph shows the interior side of the driver's side front door.

**Fig. 2-11** This data plate is a second alternative to photographing the vehicle's VIN number. If you cannot find it on the driver's side door, look on the door jamb.



**Fig. 2-12** This photograph shows the interior of the front driver's side compartment of the vehicle. To get more even fill flash, use a normal focal length lens if you have enough room to back up.

**Fig. 2-13** This photograph shows the interior of the rear driver's side compartment of the vehicle.





**Fig. 2-14** Interior of the driver's side rear door.



**Fig. 2-15** Overall view of the rear of the vehicle.



**Fig. 2-16** Overall photograph of the interior of the trunk. Two additional photographs of the driver and passenger sides of the trunk may be needed.



**Fig. 2-17** Include a photograph of the rear license plate.

**NOTE:** Follow the same photographic approach for the passenger side of the vehicle.

## IV. Autopsy Photographic Procedure

Most photographers will probably not have occasion to photograph an autopsy. In the event that such a situation should arise, however, the following guidelines are suggested.

## Forensic Photography (Imaging) 2

- A.** Seals and identification tags: these may be located on bags used for transporting bodies, on refrigeration storage units and/or the body itself. All should be photographed showing how seal is affixed and any identifiers which may have been placed on the seal or tag.
- B.** Identification photographs – particularly important if person is unidentified.
  - 1. Overall view of body, both sides.
  - 2. Frontal view of face similar to a “booking” type photograph.
  - 3. Profile of face, both sides, again similar to a “booking” type photograph.
  - 4. Scars, tattoos and identifying marks, scaled & unscaled.
- C.** Overalls showing general condition of body.
  - 1. Body clothed (if found with clothing on), both sides and back.
  - 2. Body unclothed, both sides and back.
  - 3. Views of affected areas, unwashed, and if wounds, both scaled and unscaled.
  - 4. Views of affected areas, washed, and if wounds, both scaled and unscaled.
- D.** Lividity patterns, especially if conflicting.
- E.** Areas of special interest, scaled and unscaled.
  - 1. Wounds.
  - 2. Bruises, scratches, lacerations and fractures.
  - 3. Pattern impressions; bite marks, fabric, tool marks, etc.
  - 4. Ligatures, bindings, knots, asphyxial devices, protruding items, etc.
- F.** Any additional photographs as directed by attending pathologist.
- G.** Copies of x-rays if desired.

## V. Scaling Photographs

In criminal investigations, properly taken, scaled photographs are indispensable in the evaluation and interpretation of physical evidence. The location, relative position, appearance, physical size, depth and shape of any object that possesses potential evidentiary value should be photographed, both scaled and unscaled, using the following recommendations.

### Required Equipment

1. Single lens reflex (SLR) film camera or digital single lens reflex (DSLR) camera with manual exposure controls.
2. A sturdy tripod with a sturdy head and the capability to invert the center column and/or remount the center column at a 90° angle
3. There is also a quadra-pod (four legs) designed for close-up photography.
4. Cable release for camera.
5. Electronic flash with extension cord or other device for off-camera flash.
6. Thin, rigid, flat, accurate rulers in addition to accurate adhesive rulers.
  - a. Accurate paper stick-on type scales are acceptable for fingerprint photography.
  - b. An ABFO #2 (American Board of Forensic Odontology) “L” shaped photomacrographic scale is suggested for bite mark photography.



**Fig. 2-18** A typical latent print photograph received at the Laboratory that illustrates a common misunderstanding of what is meant by filling the viewfinder with the evidence and the ruler. This photo is useful to document where the latent prints are found on an object but is not good enough for comparison purposes.

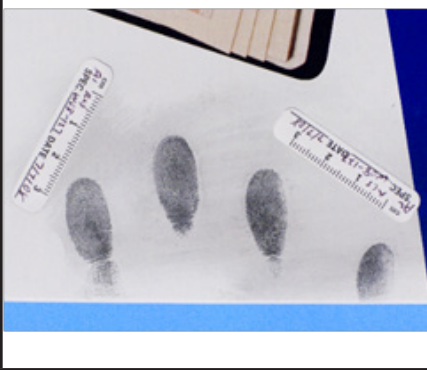

**Fig. 2-19** Example of filling the viewfinder with the evidence (latent prints) and the ruler when using film and adequate resolution digital cameras.

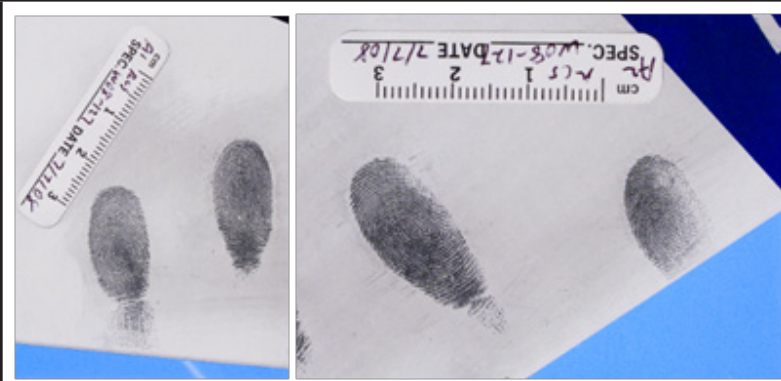

**Fig. 2-20** Digital photography may require additional close-up photographs if the resolution limits listed in Table 2-2 are exceeded. The two photographs above are examples of additional individual close-up photographs that would have to be taken of the simultaneous latent prints in Figures 2-18 and 2-19 if an 8 megapixel DSLR was used.



**Fig. 2-21** These are three enlargements of the same area from Figures 2-18 (top), 2-19 (middle), and 2-20 (bottom). In the top photograph, the combination of pixelization and relatively soft image, make it less likely that the image can be used for latent print comparison purposes. Though the center photograph is still a little soft, it is often suitable for comparison purposes. The bottom photograph shows the slight increase in image quality that can further increase the probability that the resulting photographs will be suitable for comparison purposes.

## General Scaling Recommendations

1. Camera must be placed on a sturdy tripod or camera stand (see Figure 2-22).
2. The evidence and the ruler should fill the viewfinder and be in sharp focus.
3. Film plane should be placed parallel to object plane with lens directly over center of object and perpendicular to object (see Figure 2-22). A scale should be placed on the same plane as the area of primary interest. If done properly, the scale will also be parallel to camera's film plane (see Figure 2-22).
4. Scale placement should not obscure any detail or characteristics of the subject (see Figure 2-23).
5. The scale should be as large as possible to provide accuracy for printing and size determination.
6. Avoid a direct reflection from your light source off of the scale into the camera lens when lighting the subject.



**Fig. 2-22** Typical setup for photographing a footwear impression.



**Fig. 2-23** This is an example of what **NOT TO DO**. **NEVER** place a ruler inside a footwear (or tire track) impression.

## VI. Pattern Impression Photography

### General Lighting Recommendations

Depending on the depth of the impression and the surface of material it is in/on, the light should be placed at a low angle to the impression, from 10 – 45 degrees. On-camera flash is seldom used for pattern impressions.

Light should be at a distance from the impression to evenly illuminate the entire length/width of the impression. It is important to avoid brighter areas at one end of the impression than the other end. A reflector card may be used to “fill-in” the



end farthest from the light provided the shadows or detail are not eliminated.

When the light is placed at a low angle, shadows are created that highlight individual characteristics as depicted in Figure 2-22. Oblique lighting allows for good delineation but a low angle also creates shadows that can hide important detail. To alleviate this problem, at least two photographs should be taken.

### Procedure:

1. For the first photograph, the flash is held out at a low angle at one end of the impression.
2. Advance the film making sure not to move the camera.
3. Take the second photograph with the flash held out at a low angle at the other end of the impression.
4. Additional photographs may be taken with the light from other positions relative to the impression.

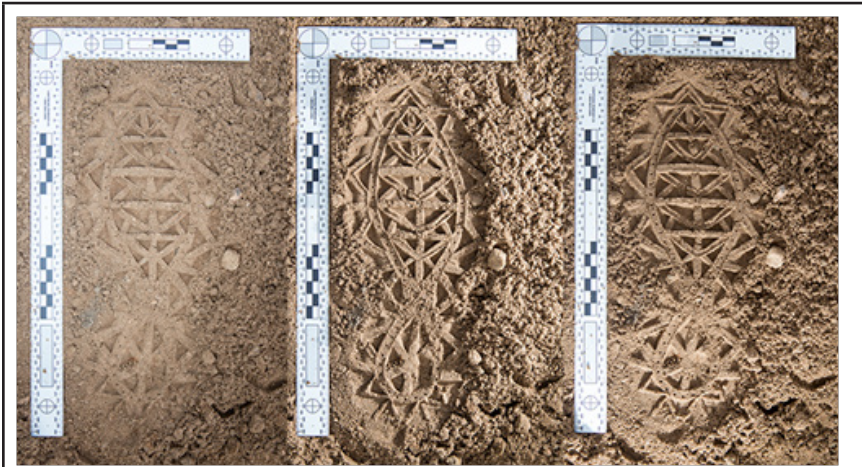

**Fig 2-24** These three photographs show the effect of the direction of light on the appearance of the details in a footwear impression. All three photographs are of the same footwear impression shown in Figure 2-22 and were taken with a black card blocking the sunlight so that the light from the electronic flash was not overpowered. The photograph on the left was taken with the flash on camera. (The light from the flash was reflected from the scale.) The center photograph was taken with the flash placed at a low angle on the left side of the impression. The right photograph was taken with the flash at a low angle at the top of the impression.



**Fig 2-25** For these three photographs, the black card was removed so that the sunlight did overpower the effects of the electronic flash. Just as in Figure 2-24, the photograph on the left was photographed with the flash on camera, the center photograph was taken with the flash at a low angle on the left side, and the right photograph was taken with the flash at a low angle from the top of the photograph.

## Footwear Impressions

1. **Camera must be on tripod!** (see Fig 2-22)
2. **Scale must be used!** (See Section V, Scaling and Fig 2-23).
3. Consider the depth of the impression and scrape away material along side of impression to provide space for the scale. Do not disturb the impression. Also, be careful not to “cave” in the sides of the impression if in soft ground, sand or snow.
4. Set the scale at the level of the deepest plane of the impression and on the same plane.
5. If an impression consists of two different levels, such as the sole level and a deeper heel impression, then three photographs are called for:
  - a. at level and plane of sole impression
  - b. at level and plane of heel impression
  - c. an overall view (scaled on plane at level of sole impression) for recording length
6. Each photograph submitted should be labeled indicating the



level at which the scale is placed.

7. The back of the camera must be parallel to both the impression and the scale with the lens directly centered over both. The image of the impression and scale should fill up the viewfinder.
8. For lighting, refer to Section VI., A., General Lighting Recommendations.
9. Digital cameras with a resolution of less than 8 megapixels are not recommended. For digital cameras with a resolution of 8 to 16 megapixels, it is recommended that the footwear impression be photographed in its entirety and then photographed in overlapping thirds (see Figure 2-26).



**Fig. 2-26** This shows the four photographs discussed in paragraph 9 above when using a digital camera with a resolution of 8 to 16 megapixels.

## Tire Impression Photography

1. The camera must be firmly mounted on a sturdy tripod!
2. An accurate, flat scale must be used!
3. If the tire impression is long, markers of some sort with numbers or letters are suggested. Visually divide the long impression into smaller sections by placing numbered

markers along the side of the impression. Do not place the markers or the ruler inside the tire track impression.

4. Once the markers have been placed, make an overall photograph of the impression from a high angle. If a section of the tire track impression is going to be cast, this photograph can be taken while the cast is drying to record both the markers and which part of the tire track impression was cast. This should also be documented in your notes.
5. Photograph each individually marked section of the tire track impression. Be sure to indicate in each photograph which section is being photographed, so that these individual close-up photographs can be oriented in sequence relative to the overall photograph and the crime scene diagram.
6. The back of the camera must be parallel to both the impression and the scale with the lens directly centered over both. The image of the impression and scale should fill up the viewfinder.
7. For lighting, refer to Section VI., A., General Lighting Recommendations.

**NOTE:** Digital cameras with a resolution of less than 8 megapixels are not recommended. For digital cameras with a resolution of 8 to 16 megapixels, each of these overlapping photographs should cover approx. 10 to 12 inches of the tire track impression with a ½ to 1 inch overlap. For film and digital cameras with a resolution over 16 megapixels, each of these overlapping photographs should cover approx. 18 to 22 inches (see Fig 2-30 and Fig 2-31). For long sections of tire track impressions, overlapping photographs of a 12 foot section of the impression will usually record the entire circumference of the average passenger car, minivan or light truck tire.



**Fig. 2-27** This is the setup for taking individual close-up photographs of sections of a tire track impressing using film or digital cameras over 16 megapixels. Cameras with a resolution of lower than 8 megapixels are not recommended.



**Fig. 2-28** This is a typical close-up photograph taken with a film camera or a digital camera with a resolution greater than 16 megapixels. In this situation, 18 to 22 inch overlapping sections are adequate to record the fine details needed for comparison purposes.

## Bite Mark Impressions

1. **Camera must be on a tripod!**
2. **A scale must be used!** An ABFO #2 photomacrographic scale and a thin accurate scale are recommended.
3. When photographing the scaled impression, the camera back must be parallel to the impression and scale with the lens directly centered over both.
4. Take an overall view of the person showing the part of the body where the bite mark impression is located.
5. Take a medium view showing the bite mark and the area around the bite mark impression.
6. Consider the depth of the impression and the contour of the area of the bite mark impression. An impression on a curved portion of the victim's body may call for more than one photograph of a specific bite mark.
7. A scale should be placed as much as possible on the same plane as area of primary interest and parallel with the impression and film plane. Remember, camera is on a tripod, camera back is parallel to impression and lens centered directly over impression. The scale should not obscure any detail or characteristics.
8. After overall and medium photographs are recorded, take an **unscaled** close-up photograph of the bite mark making sure the entire image fills up the viewfinder using lighting techniques described in Section VI., A.
9. Place a scale next to the bite mark impression as outlined in steps 6 and 7 above. Take a scaled color photograph without changing any of the equipment positions.
10. After the color images have been made, additional close-up, scaled and unscaled photographs should be produced with the digital camera set to monochrome or black and white using the appropriate black and white contrast control filters such as Kodak Wratten 25 (red), 47 (blue) and 58 or 61 (green) to enhance the bite area.
11. Additional photographs may be taken with the light from other positions relative to the impression or using a ring light so as not to create shadows, if appropriate.

**NOTE:** Depending on the appearance of the bite mark, photographs may have to be made over an extended period. This may be a time frame of several days or more, depending on whether the victim is living or deceased, the condition of body, storage facilities, etc.

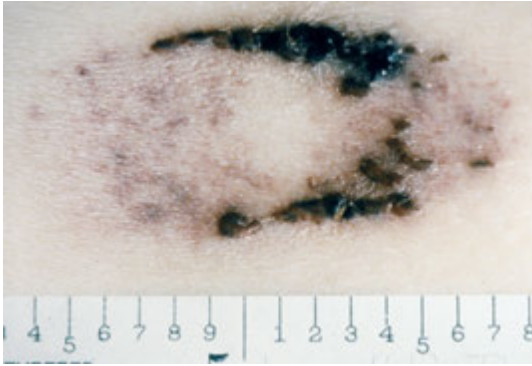

Fig. 2-29: Normal color photograph of a bite mark.

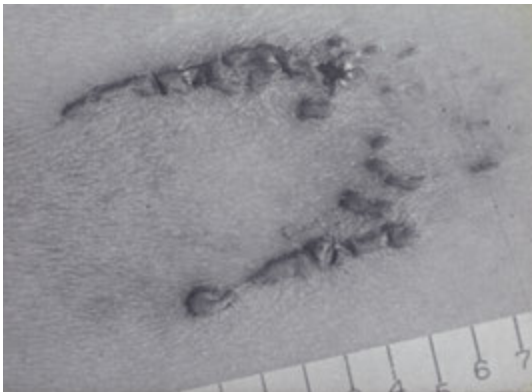

Fig. 2-30: Black and white photograph of the same bite mark with a #47 blue filter.

## Swabbing Bite Mark Impressions

After photographing the bite mark impression, the impression should be swabbed for saliva that may be used in an attempt to obtain a DNA profile of the individual who made the impression (see Chapter 7 – Sexual Offenses for the proper procedure).

**If swabbing results in uncovering more detail in the bite mark, the impression should be re-photographed.**

## **Photographs of Victim's or Suspect's Teeth**

Photographs of the teeth require specialized photographic equipment and procedures as directed by a Forensic Odontologist who will require a professional fee for services. For information concerning this service, contact the Forensic Imaging Unit of the Laboratory serving your area.

# Video and Audio Recordings

**V**ideo and audio recordings of activities continue to become prevalent in investigations of criminal activity. Recordings include

- surveillance tapes
- recordings of criminal activities such as drug buys or other investigations
- recordings by the perpetrator of criminal activities
- recordings of crime scenes and autopsies
- recordings of interviews, interrogations and confessions

*In addition, uses of video recordings by law enforcement may include:*

- A realistic view of the overall scene based on a continuous recording of what a viewer sees, rather than an overall pictorial.
- A depiction of a particular event in motion that would not be suitably depicted through still photography.
- Evidence at trials by video as provided by Wisconsin Statute §885.
- A real-time product for investigators to use for briefings, strategy sessions and interrogations.
- A record of a new or unusual technique developed in the field to process the scene or collect evidence.
- A training vehicle for use to instruct personnel.
- A review of the scene or autopsy for briefing of personnel or to verify that all the items of evidence have been recovered from the scene.

## **I. Laboratory Examinations**

In addition to being able to edit, enhance and duplicate video recordings, the Imaging Units have resources for exporting, enhancing and printing individual fields/frames from video.



Further, the Forensic Imaging Units perform comparative analysis of known objects with objects recorded in the video such as weapons, clothing, vehicles and buildings and reverse projection photogrammetry.

The following examinations are not conducted at the Wisconsin State Crime Laboratory Bureau: voice identification, audio authentication, audio enhancement, acoustical analysis and photogrammetry, except for reverse projection photogrammetry.

## II. Identifying and Labeling Video and Audio Recordings

When recording to videotape, audiotape, CD or DVD, always use new media with only one case-related event recorded on each media. It is suggested that the following information, also called an audio slate, be recorded on each video recording on the audio track:

- a. Camera operator's name, agency and address
- b. Personnel present from agency processing scene
- c. Date, time and exact location of recording
- d. Agency case number and officer-in-charge

Each video produced should be labeled as to the case name, agency number, date produced and name of videographer. The label should also be signed and dated by the videographer verifying that the video recording is a "Fair and Accurate Reproduction" and is an unedited original. The record tab should be removed from the cassette or rendered "safe" from erasure.

Do not use adhesive labels on CDs or DVDs. It is also recommended to use only markers designed for writing on CDs or DVDs. Another option is to use an inkjet printer and inkjet printable CDs and DVDs.



### III. Videography Procedures

**NOTE: It is not recommended that video be used for the exclusive recording of the crime scene or autopsy.**

#### Crime Scenes

For crime scenes, include an audio slate at the beginning (see Section II). If testimony or sound is not relevant, the camera's sound recording mode or microphone should be turned off. If a switch is not available, insert a "dummy" microphone plug into the auxiliary microphone jack. This will disable the camera's microphone. If the camera microphone cannot be disabled, care should be taken as to any sounds, or conversations that may be picked up by microphone during recording. Depending on the design, microphones on cameras can pick up sounds behind as well as in front of the camera.

Using a very slow panning speed, pan the area to provide an overall view of the entire scene. Complete 360° pans should be made of exteriors of buildings and surrounding area, looking toward the structures and also away from the structures to the surrounding area.

When taping a walk-through of the scene, a camera gyro stabilizer, shoulder brace or chest pod is recommended to steady the camera. Try to avoid "jerky" camera movements, either right to left or up and down. Movement should be as smooth as possible. An alternative to the "walk-through" technique would be to record the scene as if photographing it using the four basic views from a stationary position.

Avoid excessive "zooms". Zoom in on items only when needed to show detail and keep your zoom speed slow. Remember, still photographs are taken to record individual items and details.

Do not include equipment, personnel or unnecessary elements in your video. Be careful of reflective surfaces, such as mirrors, that may show your reflection or other items on the videotape.

If light levels are too low where camera will not record or

## Video and Audio Recordings 3

camera gain must be used, consider using an on-camera video light or additional light source.

**NOTE: A few video camcorders have a night time monochrome setting that uses visible and IR light which could result in some dark objects being recorded with a lighter tone than expected. This night time setting is more useful for surveillance work.**

Avoid the use of any in-camera video effects such as fade-in and fade-out.

### Interviews and Interrogations

Interviews and interrogations require a different procedure than for crime scenes. See State Statutes for specific legal requirements. The following are general guidelines for consideration:

1. The audio recording is always left on.
2. The audio slate should include at a minimum the names of all persons present, the date, the starting time, the agency and the location.
3. Whenever you stop or restart the recording, an audio slate should be including in the recording to explain why the recording is being turned off or resumed.

**NOTE: If you run out of space on a tape, CD or DVD, explain this in your notes and at the beginning of the next recording.**

### IV. Duplicating Video and Audio Tapes

Duplicates should be labeled as duplicates and labeled as either “Unedited Duplicates” (no changes from original, an uninterrupted dupe from start to finish) or “Edited Duplicate” (additions, deletions or change of the sequence of events). Edited duplicates should have a log on file describing what edits were applied and who did the editing.

**NOTE: Record tabs should be removed from duplicate cassettes when duplicating is completed or rendered “safe” from erasure.**

## V. Write Protecting Audio and Videotape Recordings

Prior to viewing, duplicating, sealing and/or submitting video and audiotapes, disable the record mode by either removing the record tab or moving a slider tab to the non-record position (safe or save). These are usually located on the spine portion of the tape shell.

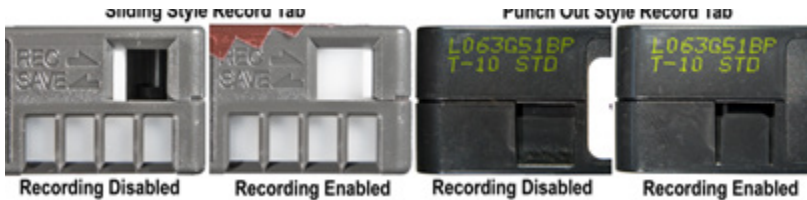

**Fig. 3-1** The first photograph (left to right) shows a sliding style record tab with the tab in the save position to disable recording. The second photo shows the record tab moved to the record position to enable recording.

**Note:** on some sliding style record tabs the record and save positions may be reversed. The third photo shows the record tab removed to disable recording. The fourth photo shows the record tab still in place to enable recording.

## VI. Viewing

Do not repeatedly view an original video or audiotape recording whether newly recorded or seized as evidence. Repeated viewing, especially in the pause mode, can damage the tape and cause information to be lost by gradually wearing out the recording surface. Instead, duplicate the original and view the duplicate. However, if analysis is needed, make sure to submit the original tape to the Laboratory.

## VII. Sealing

The actual videotape that has the evidence recorded on it is housed within a shell that can be removed to allow access to the tape within. Unless this shell is to be processed for latent prints, place some type of thin seal over the ends of the shell to demonstrate that tape access has been prevented. Seal both sides in a manner that does not interfere with normal tape operation. An alternative method is to seal the videotape in a container using accepted sealing methods (see Chapter 1 – Evidence Integrity).

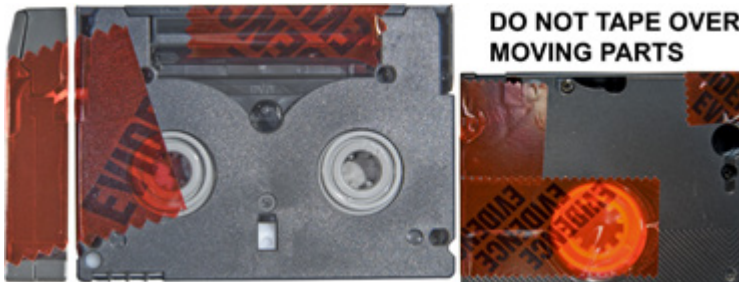

**Fig. 3-2** The three photographs above show the common mistake of taping over the moving parts of a video or audiotape cassette shell. Never tape over the moving parts of a video or audiotape cassette shell.

Do not use thick sealing materials that can jam in a VCR and do not place the seal over the record tab area or this may disable that function. The best products to use are commercially available labels made specifically for this purpose or tamper-proof tapes. The ends of the sealing tape and shell should be initialed and dated. If the tape cassette shell is to be processed for latent prints, *DO NOT PLACE EVIDENCE SEALING TAPE OR OTHER MARKINGS ON THE CASSETTE SHELL.*



**Fig. 3-3** The three photographs above show examples of the correct ways to seal and mark a videotape cassette shell. However, do not mark or place evidence sealing tape on any audio or videotape cassette shell to be processed for latent prints.

Once the cassette shells have been sealed and record tabs removed, tapes may be sealed in paper evidence bags or evidence boxes as described in the Chapter 1 – Evidence Integrity.

# Crime Scene Sketch

**T**he crime scene sketch is an invaluable aid in recording investigative data. It is a permanent record that provides supplemental information that is not easily accomplished with the exclusive use of crime scene photographs and notes. A crime scene sketch depicts the overall layout of a location and the relationship of evidentiary items to the surroundings. It can show the path a suspect or victim took and the distances involved. It can be used when questioning suspects and witnesses. During trial, the crime scene diagram correlates the testimony of witnesses and serves as a tool for relaying reference and orientation points to the prosecutor, judge and jury.

## I. Sketching the Crime Scene

Before beginning a sketch, obtain a comprehensive view of the scene. Determine the sketch limits – decide what to include and what to exclude. If the scene is complicated, a number of sketches may be necessary for adequate documentation.

### Types of Sketches

- Overview sketch – consists of a bird’s-eye-view or floor plan sketch of the scene. This is the most common type of sketch and consists of items on the horizontal plane (see Figure 4-1).
- Elevation sketch – portrays a vertical plane rather than a horizontal plane. Examples include bloodstain patterns on vertical surfaces such as walls or cabinetry and bullet holes through windows (see Figure 4-2).
- Exploded view or cross-projection sketch – consists of a combination of the first two sketches. It is similar to a floor plan except the walls have been laid out flat and objects on them have been shown in their relative positions (see Figure 4-3).
- Perspective sketch – depicts the scene or item of interest in three

# Crime Scene Sketch 4

dimensions. It is the most difficult sketch to create and requires some artistic skill (see Figures 4-4 and 4-5).

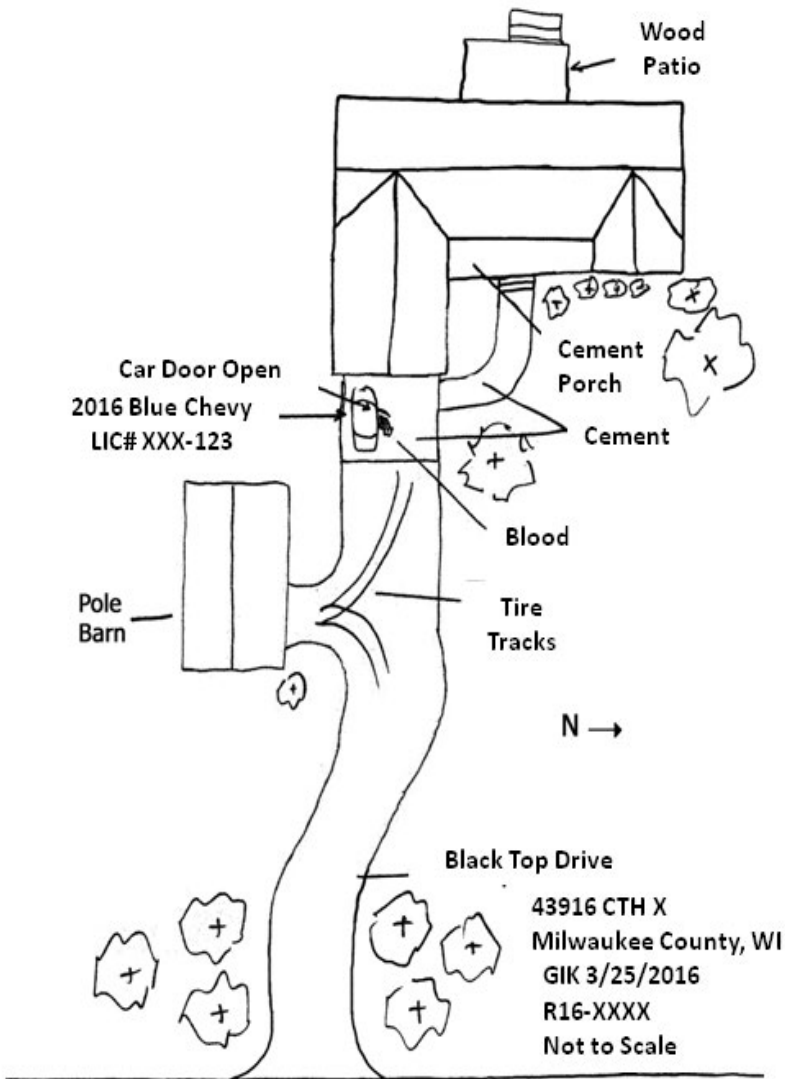

**Fig. 4-1** Overview sketch of an exterior crime scene.

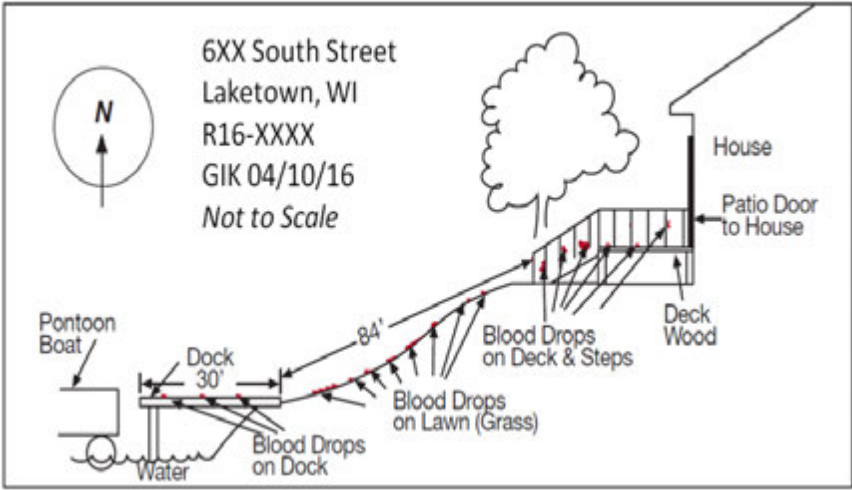

Fig. 4-2 Elevation sketch illustrating a blood trail.

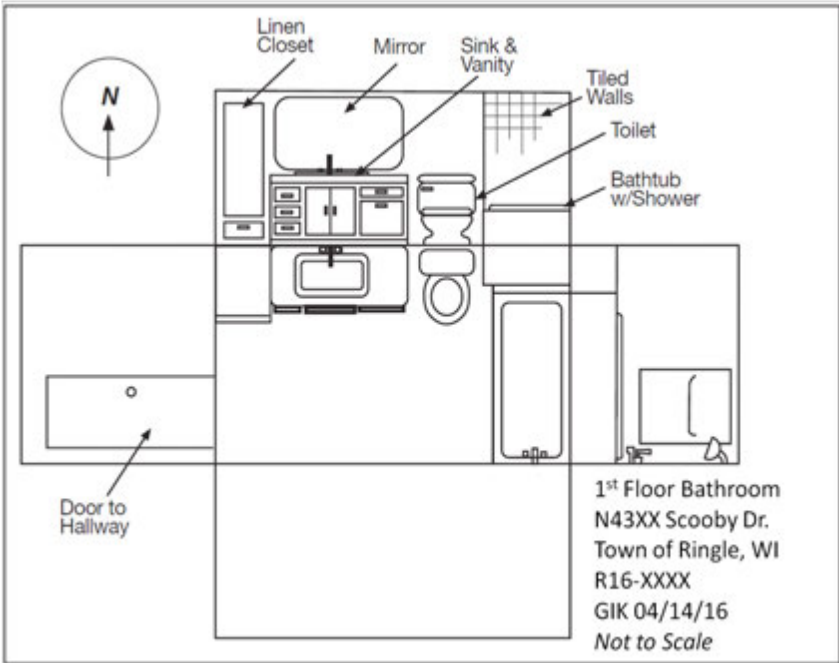
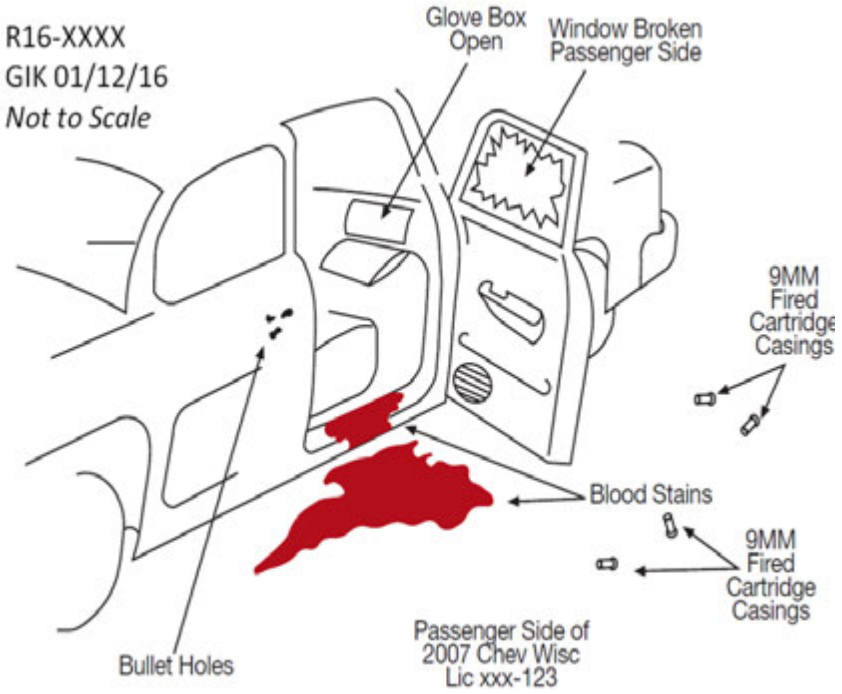
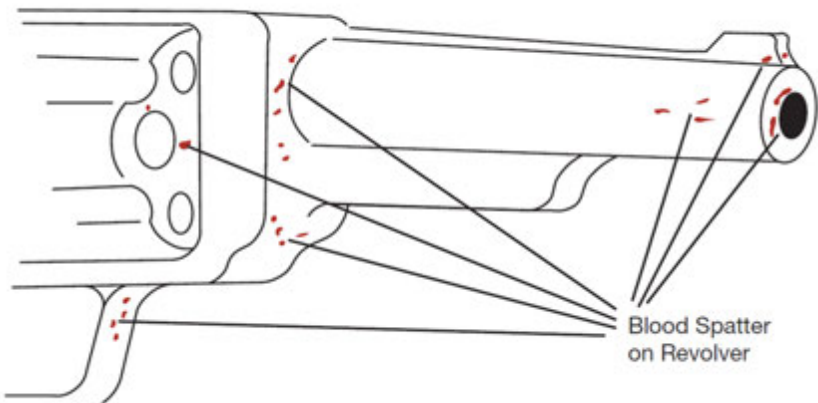

Fig. 4-3 Exploded view sketch of a bathroom.





**Fig. 4-4** Perspective sketch of the passenger side of a vehicle.



**Fig 4-5** Perspective sketch illustrating suspected blood spatter on a



revolver.

## To Scale or Not to Scale

- **“Drawn to Scale” diagrams**
  - o To avoid a distorted view of the scene, measurements must be reduced in proportion so that they bear correct relationship to each other.
  - o Select the scale of the diagram by fitting the longest dimension in the scene to the area of the paper being used.
  - o Graph paper should be used when creating this type of sketch. Each block represents a specified length of measurement. Use convenient units for the scale (one block = 1 foot).
  
- **“Not to Scale” diagrams**
  - o Sketch can be accomplished more quickly than a scaled diagram.
  - o Items are placed in the diagram based on approximation. This type of diagram may provide a distorted view of the scene. Correct proportions and relationships between objects may not be maintained.
  - o Measurements are recorded on the sketch or in a chart.
  - o This rough sketch may be used to complete a scaled diagram later.
  - o These diagrams should be clearly marked Not to Scale.

## Equipment

- Supply of writing implements – pencils may be used for the overall sketch. A sketcher may choose to use red pencils to denote bloodstains, and highlighters or other colored pencils to mark different types of evidence on the sketch. Preserve a pencil created sketch in a permanent manner as soon as possible. A good method for preservation is to photocopy the finished sketch and include the photocopy with the original.

## Crime Scene Sketch 4

- Blank paper – graph paper, while not essential, simplifies scale drawing.
- Drawing surface such as a clipboard.
- Measuring devices – tape measures are the most common tool used and should be at least 50 to 100 feet long. Other measuring devices may include a surveyor's wheel, a laser rangefinder, or a Total Station. GPS coordinates may be useful in locating an outdoor scene.
- Ruler for drawing straight lines, drawing to scale, and making very short measurements.
- Magnetic compass to determining true north.

### Creating the Sketch

- If the scene is large, make a very rough sketch of the area while obtaining an over-all view of the scene. This initial rough sketch serves as a reference when making more complete sketches. Enlarged sections of this rough sketch can be made as separate drawings in order to bring out greater detail.
- Begin taking measurements and laying out a rough sketch.
  - o Lay down a baseline. This usually consists of the longest uninterrupted side of a room or, if outdoors, the curb line, building line, or even an imaginary line between two fixed points.
  - o Take other measurements of the periphery of the scene and add them to the baseline.
  - o Having established the outer boundaries of the sketch, add various objects in their proper positions.
- Measurements – write them down!
  - o Measurements can be recorded directly on the sketch or in a chart.
  - o Long distances may be measured with the odometer on an automobile.
  - o Critical measurements should be checked by two people.

## Locating Objects on a Sketch

All points require two measurements for a two-dimensional sketch. Three measurements are required for a perspective (3-D) sketch.

- Rectangular coordinates – an object (item 1, see Figure 4-6) is located by making a measurement at right angles from each of two walls. Works well for indoor measurements.

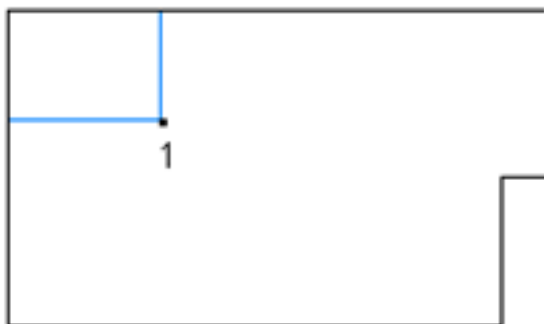
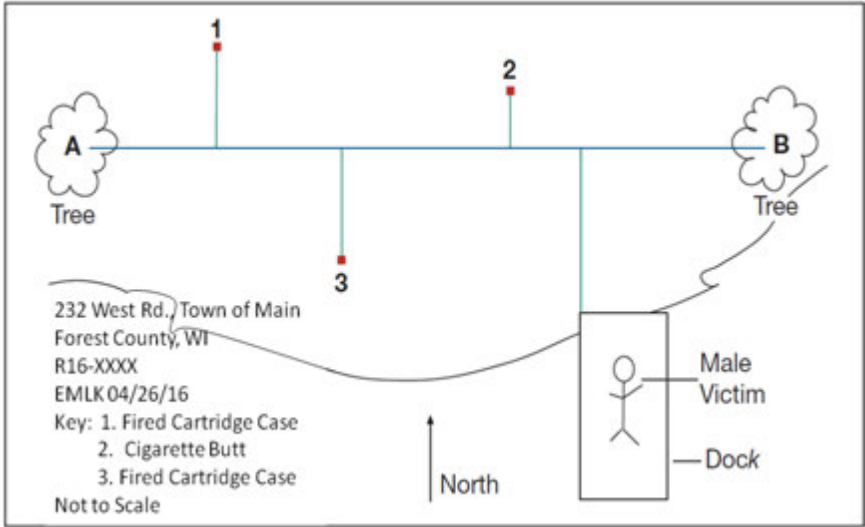

**Fig. 4-6** Item 1 is located using rectangular coordinates.

- Transecting baseline - particularly useful in large, irregularly shaped outdoor areas.
  - o Transect the crime scene by laying down a tape measure along some convenient line so it crosses the entire area (blue line, see Figure 4-7).
  - o Locate this line in the diagram from fixed points at the scene.
  - o Locate objects in the crime scene by measuring their distance from this established baseline. Measurements must be taken at right angles to the tape.
  - o Record how far along the baseline the distance out to the

# Crime Scene Sketch 4

object was measured. This provides the two measurements needed to locate the object.



**Fig. 4-7** Transecting Baseline. The blue transecting baseline AB is between two trees (trees can be marked with orange paint for later identification). The two measurements needed for each point are (1) how far each item is from the baseline (green lines north and south) and (2) how far east on the blue baseline from point A the objects are (distance to where the green lines intersect the blue). (This is for illustration. Additional measurements would be collected for the body and the dock.)

- Triangulation – measurements are taken from two fixed points at the scene to the object you desire to locate. For example, item 1 in Figure 4-8 is located by taking measurements (length of the green lines) from two corners of the building.

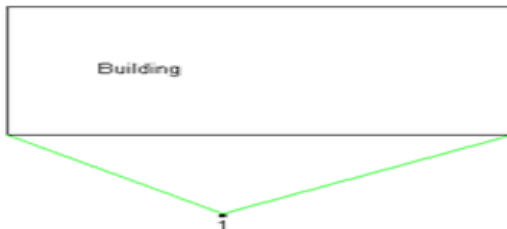

**Fig. 4-8** Triangulation. Item 1 is located using triangulation from the two corners of the building.

## Illustrating the Sketch

- Do not attempt to draw an object as it appears. Use symbols instead.
- Use lettered or numbered squares, circles, figures, or points to represent various objects in the sketch. Explain in the diagram key what these objects represent.
- If photography markers are used, ensure they correspond to same objects in the sketch. For example, if photo marker #5 is used to mark a handgun, make sure the handgun in the sketch is labeled #5.
- Label all doors and windows. Show with a curved line which way the door swings.
- Use an arrow to show the direction of the stairway.
- Use jagged lines to cut off unnecessary height or length.

## Labeling the Sketch

The following should be recorded on the sketch:

- Address or location of scene.
- Case number.
- Date sketch was made and by whom.
- A key to identify the different objects in the sketch.
- An arrow to show the direction of north.
- Scale used for the sketch or the statement “Not to Scale”.

## II. Computer Based Programs

Several CAD based programs are commercially available and can be used to create professional and accurate crime scene diagrams.

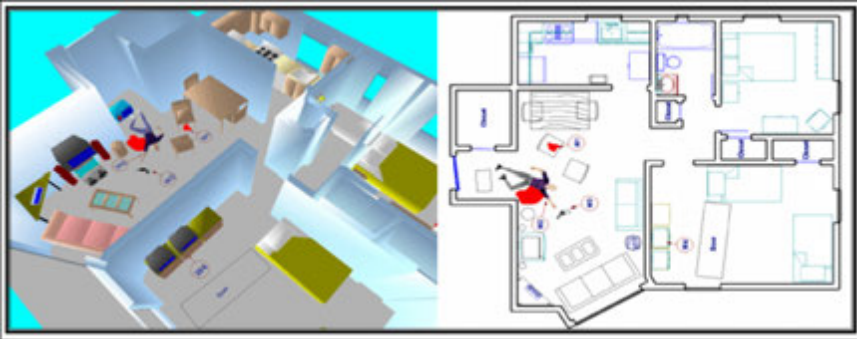

**Fig. 4-9** Diagrams created using The Crime Zone™ software\* and used with permission of The CAD Zone, Inc.

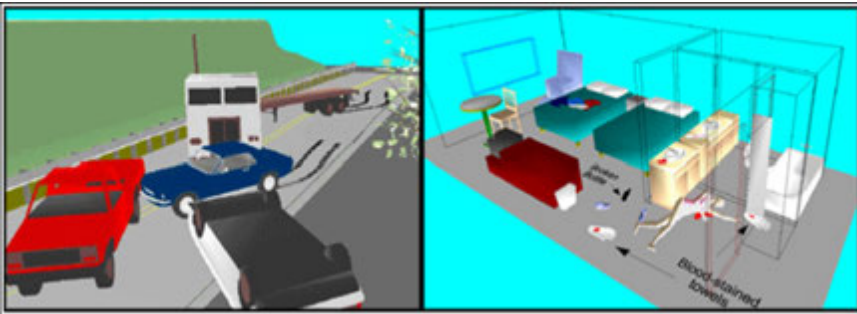

**Fig. 4-10** Diagrams created using The Crime Zone™ software\* and used with permission of The CAD Zone, Inc.

These types of programs can be used at the scene to record measurements and generate sketches or used at the office using rough sketch(es) created at the scene to generate sketches.

### III. Latest Technology

Portable devices now exist that can perform a 360° scan of a crime scene in as little as 20 minutes, capturing millions of measurements of all objects visible to the scanner. Dozens of high-resolution images are captured automatically. The device requires only the space needed by a standard photographer's

tripod. The data generated can be used to find the distance between any two points in the scene, to view the scene from any vantage point (including directly overhead), and to create a full-color, 3D model for investigative and courtroom purposes.

The National Institute of Justice's Forensic Technology Center of Excellence (FTCoE) at RTI International directed an effort with criminal justice system communities, law enforcement, industry, and forensic input to conduct a landscape study of 3D laser scanning instruments. The study was summarized, is soon to be posted by FTCoE, and was located at commercial websites in abridged and complete forms at the time of this publication (see Leica's abridged version and Riegl USA's complete version\*).

**\*Note:** The Laboratory does not endorse any one software program or device over another, nor does it endorse any one vendor over another.



# Notes

# Bloodstain Pattern Analysis

**B**ecause certain scientific principles can be applied to blood, what may appear to be a random spatter of bloodstains at a crime scene allows a trained bloodstain pattern analyst to examine and draw useful conclusions as to how the blood may have been distributed. Information gathered from the bloodstain patterns and other marks associated with it has proven a worthwhile forensic application.

## I. Documenting Bloodstain Patterns for Analysis

The examination of bloodstain patterns has always been a part of crime scene investigation, but has gained more emphasis in recent years as a separate discipline. Careful observation, measurement and documentation of the size, shape and pattern of bloodstains can reveal significant information in some cases, e.g., direction and angles of blood spatter, origination point(s) and the minimum number of blows in a beating or stabbing incident.

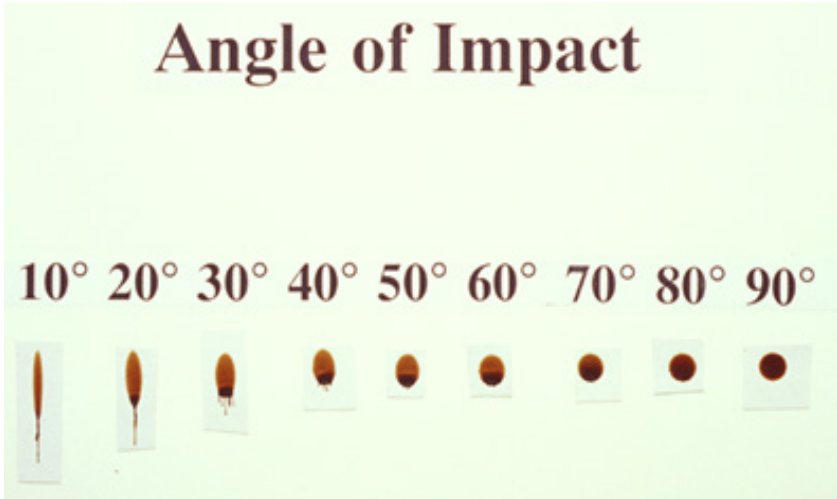

**Fig. 5-1** The chart above demonstrates how the appearance of a blood drop will change depending on the angle in which it impacts a surface. A blood drop that falls straight down at a 90° angle to a surface will be round in appearance. As the angle of impact becomes more acute, the blood drop elongates.

When bloodstains are found at a crime scene, the following information should be documented:

Physical state (fluid, moist, dry)

- Amount present (few drops, small pool)
- Shape (smear, round drops)
- Exact location in relation to fixed objects
- Pattern of stains (all in one spot, trail)
- Atmosphere conditions (temperature, humidity)
- Date and time of observations
- Scaled and unscaled photographs of stains (see Chapter 2 – Forensic Photography). Videography is also an option.

It is essential to preserve bloodstain patterns until a trained bloodstain pattern analyst can examine the patterns. Although photography and videography are useful in recording some of the aspects of bloodstains at a crime scene, it does not substitute for the detailed examination.

Further information and guidance on bloodstain pattern analysis, training, and quality assurance in bloodstain analysis can be found at the resources location of The Scientific Working Group On Bloodstain Pattern Analysis (SWGSTAIN) <http://www.swgstain.org/resources>. The site also contains a document of recommended and defined terminology useful when working with or discussing bloodstain patterns.

# DNA Evidence and Standards

**O**ne of the most important developments in the field of forensic science in the past few decades has been the implementation of DNA testing. With this testing, crime labs can match stains to individuals and test extremely small amounts of biological material to assist forensic investigations. Wisconsin DNA laboratories work to adhere to the quality standards put forth by the FBI in their Quality Assurance Standards for Forensic DNA Testing Laboratories that influence guidance provided below.

## I. Introduction

DNA, which stands for deoxyribonucleic acid, is the genetic material (or “blueprint”) that determines the characteristics of all living organisms. It is what provides uniqueness among human beings. While the vast majority of DNA is the same in humans, enough variations exist to allow discrimination between individuals with the exception of identical twins. DNA is found in all nucleated cells (except red blood cells) and is the same throughout an individual’s body.

The DNA of a person does not change over the course of his life so that person’s DNA profile always remains the same. (The only exception would be a bone marrow transplant recipient.) Half of each person’s DNA is inherited from their mother and half from their father. This is why DNA can be used in paternity testing. DNA is also a very robust molecule and can yield results years after a stain is deposited.

There are many applications of DNA testing beyond the field of forensics. It has been used in paternity testing, plant research, identification of missing persons and unknown remains, tissue matching for transplants, and identification of remains after mass disasters. DNA testing was used extensively after 9/11 to identify victims.

There are three types of forensically interesting DNA: nuclear, Y chromosome, and mitochondrial.

### Nuclear DNA

Nuclear DNA is found in the nucleus of cells and is the type of DNA testing generally utilized in crime laboratories. Nuclear DNA is unique to an individual with the exception of identical twins. The areas of DNA that are forensically significant provide no significant information about that individual other than sex.

### Y Chromosome DNA

Y chromosome DNA is found only on the male sex (Y) chromosome and is therefore present only in males. This type of DNA is passed on from father to son through the **paternal** bloodline, so a man, his brothers, his father and his male sons will all have identical Y DNA (barring a mutation). Y DNA testing is very useful for samples where a high level of female DNA is mixed with a much lower amount of male DNA. If nuclear testing was used on such a sample, the female DNA may mask any other profile present; however with Y chromosome testing, the female DNA is in effect ignored, revealing only the male DNA. While not as discriminating as nuclear DNA, Y chromosome DNA may provide valuable information in a case.

### Mitochondrial DNA

Mitochondrial DNA is not found in the nucleus of cells but rather in the mitochondria, the part of the cell where energy is produced. Like Y DNA, mitochondrial DNA is not unique to an individual and is passed through the **maternal** bloodline. Barring a mutation, all maternally-related family members will have identical mitochondrial DNA. As a result, forensic comparisons can be made using a reference sample from any maternal relative. This type of DNA testing is used primarily on hairs and bones, very old remains, and remains that are severely degraded such as after a mass disaster.

Mitochondrial DNA testing is not available at the Wisconsin State Crime Laboratory Bureau but is available at no charge

from the FBI. A number of private laboratories also conduct mitochondrial DNA testing for a fee.

### **STR Analysis (STRs)**

The type of nuclear and Y DNA testing currently in use in Crime Laboratory Bureau is called Short Tandem Repeat analysis (STRs). STR analysis looks at short pieces of DNA which are repeated a specific number of times at a particular location on the DNA molecule. Think of it as analogous to railroad cars: each person has two tracks, one from each parent. On one track an individual might have five repeats (or boxcars); on the other, six repeats. At that particular location, that person has a type of 5, 6. Other people in the population may be the same type at that location, but as more and more locations are typed, differences between individuals will be obvious. The Laboratory currently analyzes 23 different areas of DNA.

The advantages of STR DNA testing are many. Due to the sensitivity of this method, results can be obtained from extremely small and/or degraded samples. This method is extremely sensitive and uses very small amount of material. It is also highly discriminating among individuals.

There are also disadvantages to this type of testing as well. Because of its sensitivity, care must be taken to prevent the introduction of extraneous DNA at a crime scene or during collections. Mixtures of DNA from different people are also common, especially on touched items, which can make interpretation of the results difficult or impossible. In instances when an adequate amount of material cannot be obtained, a minimum amount of DNA is still necessary for testing.

Despite the revolutionary ways that DNA testing has changed forensic analysis, there are still some limitations to be aware of:

- casual contact does not generally transfer enough DNA for analysis,
- DNA can be removed by washing,
- DNA analysis cannot be performed in a few hours or

overnight,

- analysts need to be able to identify a stain on an item or know where DNA might be deposited on an item,
- DNA analysis cannot determine when a stain was deposited on an item, and
- environmental factors such as mold, heat, humidity, bacteria and sunlight can destroy DNA very quickly.

## II. Collection of DNA Evidence

### Commonly Collected

- Bloodstains – Can be on anything including clothing, bedding, weapons, objects, vehicles, and fingernail scrapings.
- Semen Stains – Can be found on clothing, bedding, swabs from victims or suspects (sexual assault kits), condoms, carpeting, upholstery, objects, and vehicles.
- Saliva Stains – Commonly found on cigarette butts, swabs from victims, bite marks, stamps, envelopes, bottles, cans, and clothing.
- Vaginal Secretions – Clothing from suspects, external penile swabbings, condoms, objects, and fingers.
- Tissue (Skin cells) – Fingernail scrapings, visible material from a vehicle or a weapon, tape or ligatures, intimate objects, eyeglasses, earrings, clothing (for wearer), guns or knives (grips/handles).
- Hair Roots – Head hairs from intimate objects, pubic hairs from clothing/intimate objects/ pubic hair combings. NOTE: Must have cellular material attached for STR analysis.
- Perspiration – Hats, jackets, ski masks, bandannas, gloves, handled objects, weapons, eyeglasses, etc.

### May Be Collected

- Urine – Large dried stains are generally not useful due to lack of cellular material present. May collect very small dried stains such as a droplet or two of urine by swabbing the stains.
- Feces – Lack of results in many cases due to large amount



of bacteria present in fecal material. Fecal material must be collected by swabbing the exterior surface. (**Must be swabbed**, see collection technique below.)

- Vomit – Contains acids and bacteria as well. Possible to get results or partial results. (**Must be swabbed**, see collection technique below.)
- Food – With a bite or bites out of it.
- Drug baggies – The Laboratory chooses a representative sample from submitted baggies for analysis.
- Fetal tissue – For criminal paternity only. Have tissue screened by a doctor or pathologist to obtain fetal (not maternal) tissue and cut a small piece for analysis.
- Cars – Can be considered a crime scene. Determine what question(s) need to be answered and transport to the laboratory in a manner that will preserve any evidence. Consider the length of time between an incident and the seizure of the car as well as environmental conditions.
- Touched items – Frequently result in uninterpretable mixtures. DNA works best on continually touched items (steering wheel of stolen car, hammer/slide of gun). Do NOT collect the following swabs from **public** places unless there is body fluid present or direct evidence that the object was touched or handled by the individual in question:
  - o Floor swabs
  - o Countertop swabs
  - o Door knob/handle swabs

## Contamination Prevention During Collection

The prevention of contamination is of vital importance in DNA testing at all stages of an investigation. The most important steps to always take are as follows:

1. Wear proper protective clothing:
  - Gloves
  - Mask/face shield
  - Glasses
2. **Do not handle any items without gloves. Change gloves after handling each item.**
3. Double glove if desired. May change only top gloves after

each item collected.

4. Avoid handling any item where the DNA may be deposited – you will wipe it off (even with gloves).
5. **Do NOT talk, cough or sneeze on or near DNA evidence.**
6. Put each item of evidence in new paper bags or envelopes – one item per bag/envelope. This includes swab boxes (except for multiple swabs from the same item or area of an item if multiple areas were swabbed, which may be packaged together).
7. **Do NOT** put your gloves in with the item of evidence. Dispose of them properly.

## Basic Collection Techniques

There are three basic collection techniques for both stains and touched items:

1. Collect the entire item and package in paper or a cardboard box. This is not recommended for extremely large items, such as furniture or large pieces of rugs/carpets.
2. Cut out a piece of the item with the stain for items that can be cut, such as cloth, carpet and bedding.
3. Swab the stain(s) or area(s) of interest on item. Whenever able, the “two swab” method of collection is preferred.
  - a. Proper swabbing technique for the “two swab” method is as follows:
    - Use a sterile or DNA-Free swab lightly moistened with DI water. Shake off any excess water away from the evidence.
    - Use the moistened swab to swab the targeted area gently but with enough pressure to collect the cellular material.
    - Follow the moistened swab with a sterile or DNA-Free dry swab to collect any cells remaining. This is especially important on items with hard surfaces (such as weapons, wood, etc.)
    - Thoroughly air dry both swabs and package together.
  - b. For body fluid stains, two well-coated swabs are sufficient for analysis purposes.
    - i. If the stain is dry collect at least two well-coated swabs

- using the “two swab” method above.
- ii. If the stain is still wet use at least two sterile or DNA-Free swabs and collect sufficient stain to coat the swabs well.
- c. **Control swabs are not needed.**
- d. For food, vomit, fecal material, gum and anything biodegradable:
- Freeze item before swabbing
  - Swab bitten portion of food
  - Swab exterior of vomit and fecal material to collect only the surface cells

When a sample is collected from an object, whether cut or swabbed, document where the sample was obtained. This documentation may consist of notes, a diagram and/or a photograph detailing where the sample was taken.

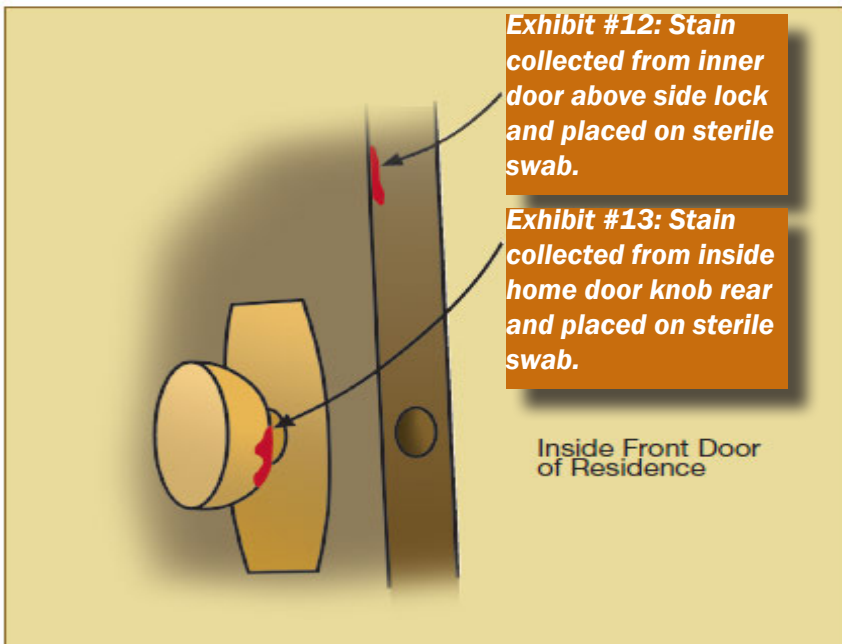

**Fig. 6-1** Above is an example of a diagram that documents where **stains** were collected from a door.

## IV. Submission of DNA Evidence

### Packaging

All submitted items should be **thoroughly** dry, always packaged in **paper** not plastic. Acceptable paper containers include clean bags, envelopes, and boxes. Each item should be packaged separately – one item per package (this includes swabs with the exception that all the swabs collected from the same stain or touched area should be packaged together [wet and dry together].) Each package should be properly sealed and marked. It is also vital that the item be sealed in appropriately sized packages. For example, a comforter should be placed in a large paper leaf bag. Once at the laboratory, the packages will be opened and resealed, requiring room to remove the item of evidence, return it to the package after analysis and reseal the package. If enough room is not provided in the original packaging for this process, the item will be repackaged at the laboratory. All layers of packaging should be labeled (one envelope inside another, swab box inside a bag, etc.).

Knives and other sharp items (such as broken glass, syringes, etc.) **should be protected so as not to penetrate the packaging.** Place these items in a sharps container or tie them down in a heavy cardboard box. Any holes or gaps in the box or other packaging must be covered with tape to prevent loss of or contaminating the evidence. For submitted weapons, wrap handles/touched areas separately from any body fluid stains on the weapon if DNA analysis of those areas is desired. This prevents cross-contamination.

### Submission

Proper submission of evidence, including all relevant paperwork, is important at the Laboratory to process evidence in a timely fashion. The submitting agency should collect everything that may be of value in the investigation. If a large number of items are collected, do not submit everything to the laboratory at once – pick the most probative items to submit initially, keeping the remaining evidence available

to be submitted later if necessary. Please see the Crime Laboratory DNA Unit evidence submission guidelines for further specifications on acceptable item submission. This document can be found on WILEnet (<https://wilenet.org/>).

All evidence packaging should be clearly marked with the agency number and exhibit number, the officer's initials, and the date of collection. Documentation of evidence on the Laboratory transmittal forms should accurately reflect the contents of the package. The submitter should explain on the Laboratory transmittal how DNA may be of use for each item submitted. A detailed summary of the incident, including ALL types of contact in a sexual assault should accompany each case, as well as a list of all items collected whether or not they were all submitted to the laboratory. If you have any questions, please contact the DNA Analysis Unit at either laboratory:

(414) 382-7500 – Milwaukee | (608) 266-2031 – Madison

### III. Storage of Evidence

Proper storage of evidence is vital in preserving any DNA present on the items submitted before submission to the Crime Laboratory. For short term storage, room temperature is fine for most items. Liquid samples (blood, urine, etc.) should be refrigerated; food, fecal material, fetal tissue and vomit should be frozen to prevent growth of bacteria and mold. The storage area should be a dry, cool environment (use a dehumidifier if necessary). DO NOT store these items packaged in plastic as it promotes growth of mold and bacteria which destroys DNA rapidly. Transport biological evidence to the Laboratory as soon as possible.

For long term storage (after analysis at the laboratory), the agency will need to properly store and preserve the evidence per state law. All DNA return packets need to be frozen in a **FROST-FREE FREEZER** sealed in plastic. Liquid samples (blood, urine, etc.) should be refrigerated or frozen. Food, fecal

material, fetal tissue and vomit should also be frozen to prevent growth of bacteria and mold.

### VI. Standard Samples for DNA Analysis

The submission of standard and particularly elimination samples allow for comparison of DNA from known individuals to DNA from items of evidence. The comparison provides opportunity for potential individual inclusion or exclusion as contributor to a DNA profile.

#### Standard Samples

Standard samples are presumed to have been present at the scene in question and are free from contamination. Standard samples are recognized during investigation and subsequently collected as known standards. Primarily, the only acceptable types of known standards received for DNA analysis at the Laboratory are:

- Buccal swabs (preferred) – taken from the inner cheek
- Dried blood stains spotted on blood preservation cards from drawn liquid blood.
- Liquid blood samples drawn into an EDTA (purple-top) blood collection tube.

All layers of packaging for known standards need to be labeled at a minimum with the individual's name and date of birth. This includes labeling each swab box and tube of blood. When using buccal swabs for suspect standard collection, a fingerprint from the individual may be placed on the swab label as well for additional identification.

#### Elimination Samples

An elimination sample is a particular form of a standard sample and is important in all types of DNA cases, especially with the dramatic increase in submission of touched items. In many cases, elimination samples are now **REQUIRED** for the Combined DNA Index System (CODIS) upload purposes (See Chapter 8 DNA Databank for more on CODIS).

Elimination samples are needed for the following individuals:

- prior consensual partners in sexual assault cases (contact of up to 120 hours prior to assault)
- owners of vehicles/homes/businesses and individuals with legitimate access to swabbed items (i.e., the regular driver of a stolen car or owner of a burgled home)

The reason to collect elimination samples is similar to the reason for collecting elimination fingerprints. The samples are used by the Laboratory for elimination purposes – to intentionally exclude samples due to legitimate access to the scene in question. These samples **are not eligible for entry into the State DNA Database** and are returned to the submitting agency after analysis is completed.

Prior to return of standard samples, they are entered into a quality assurance index at each respective DNA laboratory for the investigation of any possible contamination event. The quality assurance index represents all local DNA lab contact where standard and elimination sample profiles are maintained within the respective laboratory's larger local index system for a limited time and are deleted in approximately 90 days.

## VII. Local DNA Index System (LDIS)

The Local DNA Index System (LDIS) is a compilation of different database indices established by the local laboratory. As earlier mentioned, the quality assurance index is a part of LDIS where casework DNA profiles are also stored as forensic profiles to include mixture profiles, partial profiles, and single source unknown profiles. LDIS is maintained locally and administered locally for compliance and connectivity to larger database indices outside of the laboratory while providing the most comprehensive local storage of DNA profile data to assist forensic investigations. There is an LDIS laboratory in Madison and one in Milwaukee.



# Notes

# Sexual Offenses

*I*t is essential to have the victim(s) examined by a medical professional as soon as possible after the assault and before the affected areas (pubic area, vagina, rectum, etc.) or clothing are washed or cleaned.

## I. Evidence Collection Kit

The Laboratory has made available the Medical-Forensic Evidence Collection Kit (formally known as and still referred to as Sexual Assault Evidence Collection Kit) to assist attending medical professionals in collecting specimens required by the Laboratory in sexual assault cases.

This kit contains detailed instructions that should be used to collect appropriate samples from both male and female sexual assault victims and suspects. This evidence can be collected up to 120 hours after the assault.

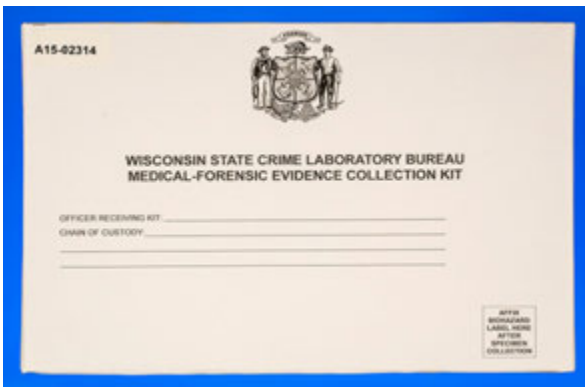

**Fig. 7-1** Medical-Forensic Evidence Collection Kit

This kit can be obtained by authorized customers at no charge from Document Sales (<https://docsales.wi.gov>).

**NOTE:** USE STERILE SWABS WHEN COLLECTING EVIDENCE OR STANDARDS.

## Collecting a Buccal Swab Standard

Prior to collecting the sample, have the person rinse his or her mouth with water. Using one swab, place the swab in solid contact with the inner cheek and gum surface. Gently move the cotton tip in and out five or six times rotating the swab while rubbing. A slight indentation should appear on the exterior of the cheek if the correct pressure is being applied. Repeat this process with a second swab on the other inner cheek and gum surface. Allow swabs to thoroughly air dry. Package the swabs together in a clean, properly labeled paper envelope and seal. **DO NOT COLLECT FROM THE TEETH OR ALONG THE EDGES OF THE TEETH.**

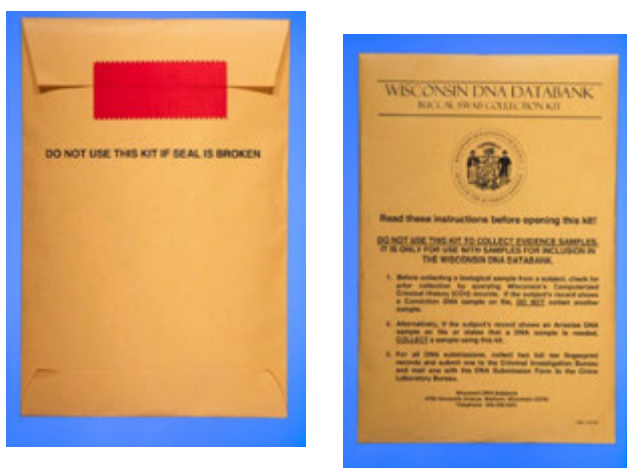

Fig. 7-2 Buccal Swab Collection Kit



Fig. 7-3 Inside the Buccal Swab Collection Kit

## II. Transitory Evidence Collection

### Fingernail Scraping

When there is reason to believe evidence may exist under the patient's fingernails such as blood, skin, hair, fibers, etc., the fingernails should be gently scraped with a wood or plastic applicator stick or toothpick into a clean, paper envelope. Alternatively, the fingernails can be clipped and the clippings placed into the envelope. Each hand should be done separately (**not** each finger). Properly label and seal each envelope.

**Fingernail swabbings** can be used if the fingernails are short. Moisten the swab with sterile water and swab the front edge of the fingernails. Use one swab for each hand. Allow the swab to thoroughly **air dry**. Package the swabs in a clean, properly labeled paper envelope and seal.

### Finger Swab(s) (Suspects Only)

If the victim was digitally assaulted, the suspect's finger(s) should be swabbed with a swab (one per hand) moistened with sterile water. Follow the wet swab with a dry swab ("two swab method"). Allow swabs to thoroughly **air dry**. Package the dried swabs in a clean, properly labeled paper envelope and seal.

### Bite Marks

Bite mark evidence must be photographed to document the impression. The specific method to properly photograph this type of evidence is described in [Chapter 2 - Forensic Photography](#).

The bite mark impression should also be swabbed using a swab moistened with sterile water to collect any potential traces of the assailant's saliva. Re-swab the impression with a second **dry** swab to collect any remaining traces (the "two swab method"). Allow the swabs to thoroughly **air dry**. Package the swabs together in a clean, properly labeled paper envelope and seal.

## III. Additional Relevant Physical Evidence

### Clothing

Articles of clothing worn by the victim and suspect (if possible) should be collected for submission to the Laboratory to be examined for seminal stains, blood stains, foreign hairs and fibers or other trace evidence adhering to the clothing. In addition, items at the crime scene may provide important evidence that associates the victim and/or the suspect to the scene.

Procedure for clothing:

1. Clothing of the victim must be kept separate from those of the suspect at all times.
2. Clothing worn at the time of or immediately after the offense must be recovered and preserved. This includes undergarments, towels, tissues, and sanitary napkins and/or tampons (only if used during or immediately after the offense).
3. Garments should be handled as little as possible to avoid the loss of trace evidence.
4. Package each item of clothing **separately** in a clean, properly labeled paper bag and seal.

### Condoms

When condoms are recovered in suspected sexual assault cases, the amount of possible seminal fluid in them should be a consideration during collection, packaging and storage. Because DNA from the victim may be identified on the outside of the condom, great care should be taken to minimize leakage of semen from inside the condom. If little liquid appears to be in the condom itself, it can be placed in a glass specimen jar and frozen until submitted to the Laboratory. If a large amount of liquid is present, leakage is a concern and one of the following procedures should be used:

*Alternative One*

1. Attach the opening of the condom (with the fluid inside) to

the top or side of a specimen jar so the fluid cannot leak out.

2. Label the jar so it is maintained in an upright condition.
3. Freeze the jar until submitted to the Laboratory. (Do not mail, submit in person.)

#### *Alternative Two*

1. Using dry swabs (as many as necessary) collect all or as much of the fluid from inside the condom as possible.
2. Allow these swabs to dry together but separately from the condom itself. Package in a properly labeled **paper** bag or envelope and seal. Label as collected from the condom. Submit the condom in a separate package (see step 3).
3. Stand up another set of clean, dry swabs and drape the condom over them, tent-style, with the opening of the condom at the bottom. Allow to thoroughly air dry in a protected area. Package in a properly labeled **paper** bag or envelope and seal.

## IV. Processing the Scene

1. Document the scene. See [Chapter 1 – Evidence Integrity](#), [Chapter 2 – Forensic Photography](#) and [Chapter 4 – Crime Scene Sketch](#).
2. Check for fingerprints. See [Chapter 13 – Latent Prints](#).
3. Recover articles such as towels, rags, tissues, etc., which may have been used as a wipe after ejaculation. See [Chapter 22 – Clothing and Fabrics](#).
4. Recover and submit any articles that may have become stained during the offense or might have foreign hairs present (e.g., bedding, rugs, sofa cushions, etc.). See [Chapter 23 - Hairs and Fibers](#).

### Unusual Sexual Offenses

When unusual situations are encountered, please contact the DNA Analysis Unit at either laboratory:

(414) 382-7500 – Milwaukee | (608) 266-2031 – Madison

# Notes



# DNA Databank

**T**he DNA Databank is a DNA profiles database. It is a collection of DNA profiles organized for fast search and retrieval of profile information. It is a powerful tool to potentially provide investigative leads to solve cases that have not been solved using other methods. The Databank also has the potential to associate serial cases not previously identified with the same suspect.

**Note: Wisconsin DNA Databank Buccal Swab Collection Kits referenced below are subject to change in the near future. At the time of this publication, a pilot program was targeted to implement a new and smaller collection kit.**

## I. The Combined DNA Index System (CODIS)

Networked through the Combined DNA Index System (CODIS), the Wisconsin DNA Databank has the ability to search DNA profiles at the State and Federal levels respectively. The Local DNA Index System (LDIS), previously mentioned in Chapter 6 DNA Evidence and Standards, connects to the State DNA Index System (SDIS) which links to the National DNA Index System (NDIS). The primary purpose of CODIS is to assist law enforcement agencies with leads for investigations in which biological evidence was recovered.

The FBI provides oversight of CODIS-participating laboratories and sets forth quality assurance standards and requirements for upload and search by NDIS participating laboratories with their Quality Assurance Standards for DNA Databasing Laboratories. Similarly, the Wisconsin State Crime Laboratory, sets forth procedures for upload and search within Wisconsin by SDIS participating laboratories while also in compliance of NDIS standards. Due to the standards, requirements, and procedures in place, CODIS specific rules exist for DNA profiles upload and search. As such, not all profiles obtained from items of evidence can be uploaded into the database.

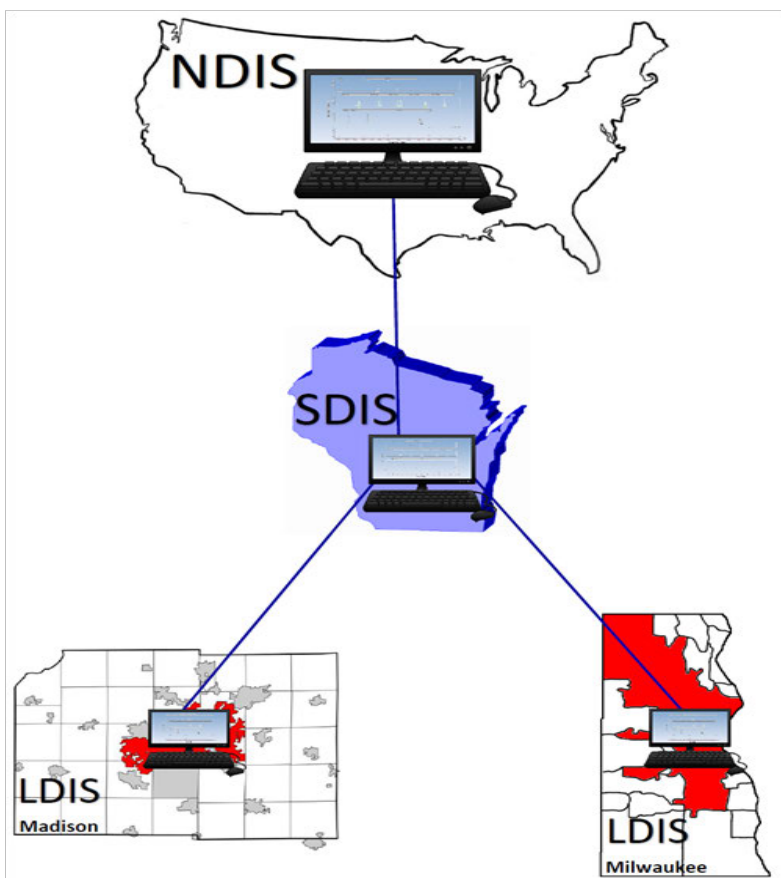

**Fig. 8-1** CODIS architecture as it relates to Wisconsin.

## II. State DNA Index System (SDIS)

The DNA Databank Unit of the Wisconsin State Crime Laboratory receives, verifies acceptability, evaluates and maintains a repository of high quality reference DNA samples of individuals required by Wisconsin State Law to provide a sample for deposit into CODIS. The DNA Databank Unit also maintains a repository of forensic evidence samples for comparisons against reference DNA samples. This collective repository for Wisconsin is referred to as the State DNA Index System (SDIS).

It is important to emphasize that a database “match” as a result of comparisons is used for investigative leads.

The DNA Databank Unit is responsible for understanding and applying the Wisconsin statutes, rules, regulations, administrative codes, and standards required to ensure the quality and security of the data stored in the database. The DNA Databank Unit is located at the Madison Laboratory.

On April 1, 2015 Wisconsin implemented Wisconsin Act 20 that enforces collection of DNA from a subset of violent felonious acts at arrest (adults and juveniles), all misdemeanor convictions from adults, a subset of misdemeanor convictions from juveniles, and all felony convictions (adults and juveniles). Wisconsin statute §165.76(1)(as) has been interpreted to be operational. That is, it was deemed that the legislative intent was to limit misdemeanor conviction collections for individuals in which the date of the offense had to have occurred on or after April 1st, 2015. In addition, Wisconsin Act 20 prevents the WSCS from processing an arrest DNA sample unless probable cause is established by the courts and requires destruction of an arrest DNA sample at one year if probable cause is not established.

The convicted offender index and arrestee index are indices of SDIS as reference DNA standards and are a part of SDIS along with profiles accepted for upload by LDIS. SDIS serves as support to LDIS as deemed necessary and when requested by the local laboratory.

### **III. DNA Databank Reference Sample Collection**

Wisconsin DNA Databank Buccal Swab Collection Kits, including a postage-paid return envelope, are available at no charge to criminal justice agencies. These kits are for the collection of DNA samples for inclusion in the DNA Databank. These kits can be used for the collection of convicted offender samples as well as violent felony arrestees. These kits are not for the collection

of evidence.

When preparing to collect a reference DNA sample, please ensure a Qualifying Event is identified. If a qualifying event is identified, confirm that a DNA collection is needed from the individual. The DNA status of an individual can be checked in either Portal or eTIME.

There are four possible DNA statuses:

- A. If the subject's record shows a Conviction DNA sample on file, DO NOT collect another sample.
- B. If the subject's record shows DNA needed (Recollect List, SAFE Team, or Missed Collection Event), proceed with collection and mark the form appropriately.
- C. If the subject's record shows an Arrestee DNA sample on file and a qualifying event has been identified, proceed with collection as normal.
- D. If the subject's record has no DNA flag or you are unable to access the subject's record and a qualifying event has been identified, proceed with collection as normal.

For more information on qualifying events, please refer to the supplemental form on WILEnet at <https://wilenet.org/>.

Once the above conditions have been satisfied, proceed with the collection of the DNA sample using the following guidelines.

**Step 1.** Remove all components from the kit envelope. Do not use the kit if the integrity seal was broken before you opened the kit.



**Fig. 8-2** Wisconsin DNA Databank Buccal Swab Collection Kit contents

There should be a total of 11 items within the kit: a white

mailing envelope, two swabs, two sets of barcodes, a pair of gloves, a loose yellow swab envelope, a yellow swab envelope inside an instruction folder, two integrity seals, and a shipping seal.

**Step 2.** Ensure the subject's mouth is empty of food, drink, or anything that would obstruct the swabbing process.

**Step 3.** Positively verify the subject's identity and then fill out the Submission Form.

Fig. 8-3 Step 3 depiction

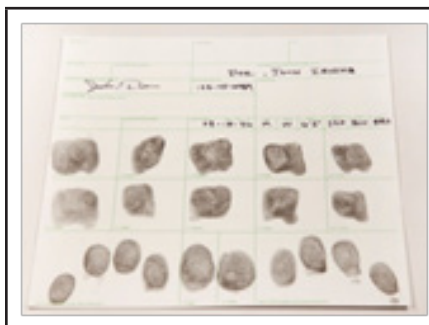

Fig. 8-4 Step 4 depiction.

Importantly, if the subject does not have a record and no State Identification Number (SID) is available you must fill out the Arrest Tracking Number linked to the charge and submit a complete ten print card to the Crime Information Bureau.

**Step 4.** Enter one left and one right fingerprint in the boxes provided on the Submission Form. Ensure they are legible. If they are not legible, additional prints can be taken elsewhere on the form and labeled appropriately, or attached on a separate piece of paper with legible, labeled left and right fingerprints. A right index fingerprint is also necessary in the box on each

yellow swab envelope. For more information on fingerprint collection, refer to the poster on WILEnet.



**Fig. 8-5** Step 5 depiction

**Step 5.** For all DNA submissions, collect two full ten print records. Submit one record to the Crime Information Bureau and mail one with the DNA Submission Form to the Wisconsin State Crime Laboratory. For more information on submitting ten print records, refer to the poster on WILEnet.

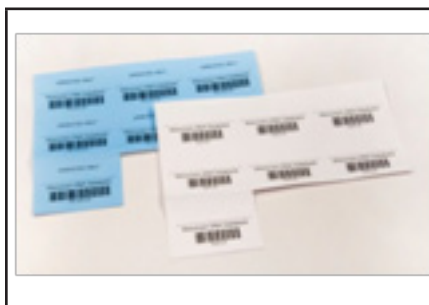

**Fig. 8-6** Step 6 depiction

**Step 6.** There are two sets of barcodes supplied within the kit. If the subject is being collected upon arrest use the blue barcodes. For all other collections use the white barcodes. In the designated locations, add barcode labels on each of the yellow swab envelopes, the Submission Form, the Instruction Folder, and on the white mailing envelope.

**Fig. 8-7** Steps 7 & 8 depiction**Fig. 8-8** Step 8 depiction

**Step 7.** Put on the single-use disposable gloves.

**Step 8.** Open one sterile swab package. Lay the package open so the sterile surface is available to air-dry the swab in the following step. Never Touch the Cotton Tip of the Swab.

Additionally at this time you can add the barcode label around each swab handle. To do this, fold the label lengthwise at the opposite end of the swab from the cotton tip. Ensure the label firmly sticks to the swab handle.

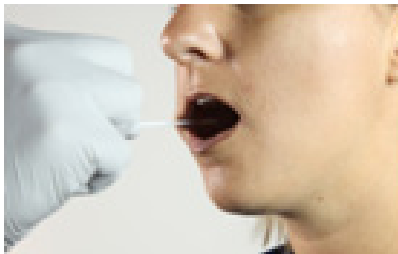
**Fig. 8-9** Step 9 depiction**Fig. 8-10** Step 10 depiction

**Step 9.** Remove the swab from the package and rub the cotton tip against the subject's inner cheek. Gently but firmly move the cotton tip in and out at least five times, rotating the swab while rubbing. It is very important that the swab be in solid contact with the inner cheek. Do not collect from the teeth or the edges of the teeth. The goal is to collect cells from the inside cheek. These cells contain the DNA for analysis.

**Step 10.** Place the swab on a sterile surface of the swab package to air-dry. Do not let the cotton tip of the swab touch anything except the sterile swab packaging. When possible, allow swabs to air-dry for several minutes before packaging them for mailing.

**Step 11.** Repeat steps 8-10 using the second swab on the other side of the mouth.

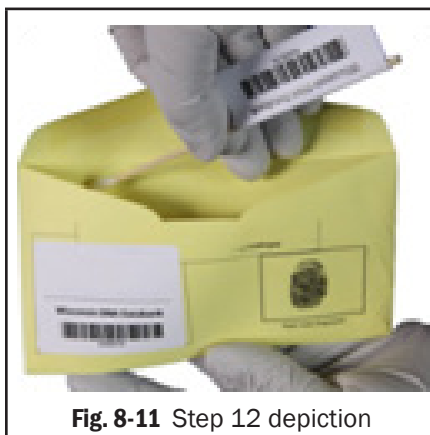

**Fig. 8-11** Step 12 depiction

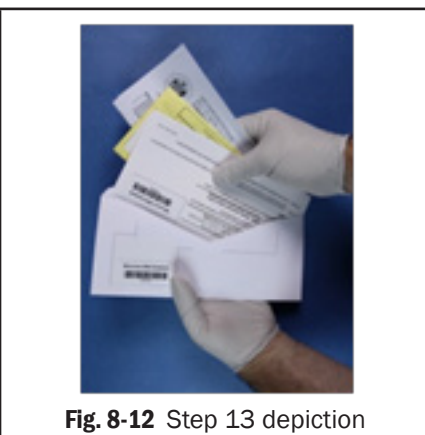

**Fig. 8-12** Step 13 depiction

**Step 12.** Place one swab in each of the yellow swab envelopes. Seal the swab envelopes using the integrity seals. Do not moisten the flap of the envelope to seal them.

**Step 13.** Place the loose yellow swab envelope inside the instruction folder. Place the folder, the ten print card, and the Submission Form in the white mailing envelope. Seal the mailing envelope by affixing the shipping seal in the designated area. Do not moisten the flap of the envelope to seal it.

**Step 14.** Ship the white mailing envelope by U.S. mail within 24 hours.

If you have questions regarding this process, please contact the DNA Databank Unit at 608-266-2031.

Kits can be obtained by authorized customers from Document Sales (<https://docsales.wi.gov>).



# Questioned Documents

**T**he application of allied sciences and analytical techniques to questions concerning documents is termed forensic document examination. The examination of questioned documents consists of the analysis and comparison of questioned handwriting, hand printing, computer generated documents, commercial printing, photocopies, papers, inks, and other documentary evidence with known material in order to establish the authenticity of the contested material as well as the detection of alterations.

*Handwriting includes cursive writing, hand printing, numbers and other marks or signs. Calligraphy and determining personality from handwriting are not part of forensic document examination.*

**NOTE: The Wisconsin State Crime Laboratory no longer accepts cases and evidence/standards for Questioned Documents. The FBI Crime Laboratory has agreed to work Questioned Documents cases that would normally be sent to the Laboratory.**

**For more information on how to submit evidence to the FBI Crime Lab, please call the Questioned Documents Unit at (703)632-8444.**

The FBI performs handwriting comparisons; Fractured/cut edge comparisons (paper, tape, postage stamps, dryer sheets); Indented writing examinations; Printing process examinations (document authentication/typewriting classification); Charred and liquid-soaked document preservation; Alternate light source examinations (ink discrimination, alterations, enhancements); Office machine artifact comparisons; and Database queries (Anonymous Letter File, Automated Counterfeit Identification Database, Bank Robbery Note File).

### I. Care and Marking of Questioned Documents

Questioned documents are subjected to a detailed examination and often yield valuable hidden information. For example, examination of a document may reveal the presence of indentations which can be deciphered photographically or with the Electrostatic Detection Apparatus (ESDA). Therefore, extreme care must be taken in handling, marking, and packaging questioned documents in order to preserve intact all characteristics, such as impressions, for forensic examination. The following procedures should be used in submitting questioned documents:

1. Avoid excess handling.
2. Handle documents with gloves.
3. Do not process chemically before submitting to a forensic document examiner.
4. Do not mark on the questioned documents.
5. Questioned and known documents should not be folded or stapled or clipped together.
6. Do not attempt to repair damaged documents with tape or glue.

Handling of question documents by suspects may also prove a good source of DNA evidence or latent print evidence. Refer to chapters on DNA Evidence and Standards, and Latent Prints for collection of the respective physical evidence.

### II. Computer Generated Documents

Computers and various printing technologies generate most of the documents in our everyday business. Examples of this type of evidence include receipts, gift certificates, images of checks, letters, mortgage documents, lease agreements, business memorandum and employment documents.

A forensic document examiner can assist you in identifying the imaging process used to create a questioned document.

Questions that occur regarding computer generated documents include:

- Is the questioned document an original or a copy?
- What is the printing technology and can it be dated?
- Was the document created with more than one printing technology?
- Is there evidence of page substitution in a multi-page document?

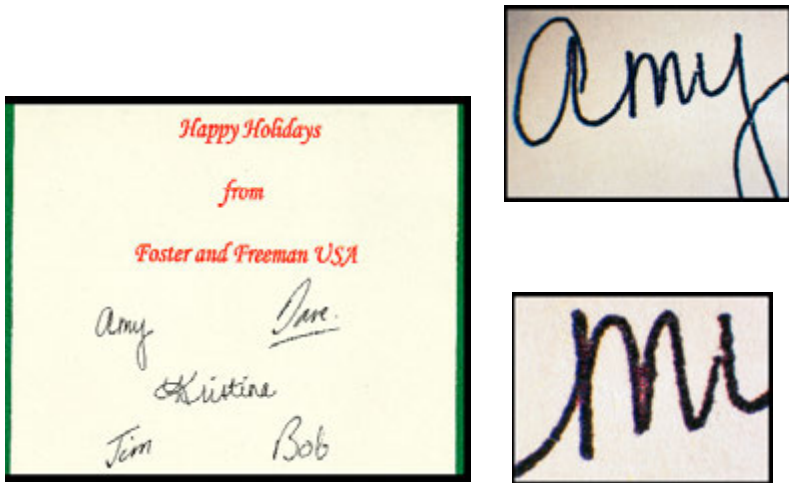

**Fig. 9-1** These images show a greeting card and photomicrographs of a signature from the card. “Amy” appears visually to be an original handwritten signature, but it was actually scanned into a computer and printed with a color laser printer. The shiny colored dots are visible under a microscope and indicative of color laser printing.

### III. Other Documents

Common questioned documents are forgeries or threats to include checks, threatening letters, anonymous letters, property registry, drivers licenses, passports, and suicide notes to name a few.

More information on the FBI Laboratory Questioned Documents Unit is found at <https://www.fbi.gov/services/laboratory/scientific-analysis/questioned-documents> at the time of this publication.

# Notes

# Firearms and Ammunition

**I**nformation here is intended to assist the investigator in the recognition, evaluation, marking, packaging, and transmittal of firearms exhibits and related items to the Laboratory.

## I. General Considerations

When requested, the Laboratory will process firearms exhibits and related items for fingerprints, DNA and trace evidence as well as the possible determinations listed in Table 10-1.

All exhibits should be properly inventoried. Record the description of the item, source, case number, item number, initials of person collecting, and the date and time collected. Sketch the area of recovery, indicating relative positions in feet and inches between exhibits and fixed objects, and supplement with photographs (see Chapter 4 - Crime Scene Sketch).

It is often possible to restore manufacturer's serial numbers, property marks, or other die-stamped markings which have been removed, altered, or obliterated on firearms (and other metallic objects such as tools, plates, and bicycles).

Firearms and fired ammunition may be delivered to the Laboratory in person or via parcel post, certified mail, or United Parcel Service (UPS).

All firearms must be shipped unloaded to the Laboratory with a marking on the package exterior indicating the firearm is unloaded. An evidence transmittal form should be sealed in an envelope attached to the outside of the package. Indicate what kinds of examinations are requested, e.g., DNA, Trace Evidence, Identification, NIBIN entry, etc.

Firearms or other metal objects recovered from water (or nonflammable liquid) should immediately be placed in a

container of the same liquid, completely submerged. When in a liquid, the oxidation process is considerably retarded minimizing change.

## II. Marking of Firearms

Use extreme care in marking recovered firearms for purposes of identification. A reinforced identification tag may be attached to the trigger guard in front of the trigger.

Mark the tag with appropriate identifying data, including the serial number and description of the firearm, source, case number, item number, initials of collector, and the date and time collected.

## III. Marking of Bullets, Fragments, Cartridge Cases, Shotgun Shells, Pellets, and Unfired Ammunition

All firearms and firearm related items should be handled with the assumption they will be fingerprinted or sampled for DNA. Therefore, only the packaging should be marked. In this way the possibility of damage, loss or contamination of trace evidence or DNA and destruction of possible fingerprints is greatly diminished. These items should not be packaged in cotton or sealed in plastic.

All packages should be properly sealed, with initials of collector over the seal, and marked with accompanying information such as the description of the item, source, case number, item number, initials of person collecting, and the date and time collected, as described in Table 10-2.

In situations where through-and-through penetration of the victim's body has occurred and the bullet is found on the floor, in walls, etc., bullets or bullet fragments should not be touched with bare fingers. A small piece of clean white paper

may be slipped under the bullet, then folded and placed in a rigid container, and finally sealed and identified. This procedure minimizes the possibility that the recovering officer will contaminate traces of blood which may be present on the bullet. The above recommendations should also apply to shotgun pellets and wads.

**Table 10-1:  
Possible Laboratory Determinations  
Resulting from Firearms Unit Examinations**

EVIDENCE REQUIRED BY LABORATORY	POSSIBLE LABORATORY DETERMINATIONS
FIRED BULLET	Make, caliber, type of firearms from which each could have been discharged; type of propellant used in firing; manufacturer and designation as to type, caliber, etc.
TWO OR MORE FIRED BULLETS	In addition to the possible determinations listed for a single fired bullet, whether two or more were fired from the same firearm.
FIRED CARTRIDGE CASE OR SHOTSHELL	Make, caliber, type of firearm in which each could have been fired; type of propellant used in firing; name of manufacturer and designation as to type, caliber, etc.
TWO OR MORE FIRED CARTRIDGE CASES OR SHOTSHELLS	In addition to the possible determinations listed for a single cartridge case, whether two or more cartridge cases or shot shells were fired in the same firearm.
FIRED BULLET AND SUSPECTED FIREARM	In addition to the possible determinations listed for a single fired bullet, whether bullet was fired from suspected firearm.
FIRED CARTRIDGE CASE AND SUSPECTED FIREARM	In addition to the possible determinations listed for a single cartridge case, whether cartridge case was fired in suspected firearm.
SUSPECTED FIREARM, AMMUNITION, SCALED PHOTOGRAPH OF POWDER OR SHOT PATTERN AND/OR VICTIM'S CLOTHING	Approximate distance at which shot was discharged.
SHOT PELLETS AND WADS	Size of shot, and gauge designation of wads.

**Table 10-2:**

**Instructions for Handling, Marking, and Shipping Firearms Exhibits**

<b>EXHIBIT</b>	<b>GENERAL INSTRUCTIONS</b>	<b>DESCRIPTIVE RECORD TO BE KEPT BY PERSON RECOVERING</b>
<b>FIREARMS</b>	Check for fingerprints. Remove magazine from auto loading firearms. Do not clean or fire. Do not operate mechanism except to unload. If loaded revolver, mark hammer position and sketch cartridge positions. See column on marking for identification.	A record of make, model, type, caliber or gauge designation, serial and lot numbers. If a loaded revolver, draw a sketch indicating position of hammer and cartridges.
<b>FIRED BULLETS</b>	Every precaution should be taken to prevent loss of trace evidence or abrading or mutilating bullet surface in any way. Do not wash or clean.	Sketch showing relative position of fired bullets collected from scene. Transmit a copy of this information to the Laboratory.
<b>FIRED METALLIC CARTRIDGE CASES</b>	Do not mar, mutilate, scratch, or nick head of case. See column on marking for identification.	Sketch showing relative position of cartridge cases collected from scene. Transmit a copy of this information to the Laboratory.
<b>FIRED SHOT SHELLS</b>	Do not mar, mutilate, scratch, or nick head of shot shell.	Sketch showing relative position of shot shells collected from scene. Transmit a copy of this information to the Laboratory.



**Table 10-2 (continued):****Instructions for Handling, Marking, and Shipping Firearms Exhibits**

<b>SHOT PELLETS</b>	Recover as many as possible. Do not mutilate in recovery.	Sketch showing relative position of shot pellets collected from scene. Transmit a copy of this information to the Laboratory.
<b>SHOT WADS</b>	Recover as many as possible. Do not mutilate in recovery.	Sketch showing relative position of shot wads collected from scene. Transmit a copy of this information to the Laboratory.
<b>LOADED SHELLS OR CARTRIDGES</b>	If unfired ammunition is recovered in investigation, forward to Laboratory. If ammunition manufacturer's boxes are recovered, forward to Laboratory for latent print examination.	Sketch showing relative position of shells or cartridges collected from scene. Transmit a copy of this information to the Laboratory.
<b>SHOT OR POWDER PATTERNS</b>	If on clothing send only the clothing that might contain powder, powder residues, or exhibit bullet or shot penetrations. If on skin, doors, walls, etc., consult Laboratory concerning scaled photographs.	Description and source of garment containing shot or powder patterns. Location and size of shot or powder patterns on walls, doors, or other immovable objects.

**Table 10-2 (continued):  
Instructions for Handling, Marking, and Shipping Firearms Exhibits**

<b>EXHIBIT</b>	<b>GENERAL INSTRUCTIONS</b>	<b>DESCRIPTIVE RECORD TO BE KEPT BY PERSON RECOVERING</b>
<b>FIREARMS</b>	Check for fingerprints. Remove magazine from auto loading firearms. Do not clean or fire. Do not operate mechanism except to unload. If loaded revolver, mark hammer position and sketch cartridge positions. See column on marking for identification.	A record of make, model, type, caliber or gauge designation, serial and lot numbers. If a loaded revolver, draw a sketch indicating position of hammer and cartridges.
<b>FIRED BULLETS</b>	Every precaution should be taken to prevent loss of trace evidence or abrading or mutilating bullet surface in any way. Do not wash or clean.	Sketch showing relative position of fired bullets collected from scene. Transmit a copy of this information to the Laboratory.
<b>FIRED METALLIC CARTRIDGE CASES</b>	Do not mar, mutilate, scratch, or nick head of case. See column on marking for identification.	Sketch showing relative position of cartridge cases collected from scene. Transmit a copy of this information to the Laboratory.
<b>FIRED SHOT SHELLS</b>	Do not mar, mutilate, scratch, or nick head of shot shell.	Sketch showing relative position of shot shells collected from scene. Transmit a copy of this information to the Laboratory.
<b>SHOT PELLETS</b>	Recover as many as possible. Do not mutilate in recovery.	Sketch showing relative position of shot pellets collected from scene. Transmit a copy of this information to the Laboratory.
<b>SHOT WADS</b>	Recover as many as possible. Do not mutilate in recovery.	Sketch showing relative position of shot wads collected from scene. Transmit a copy of this information to the Lab.
<b>LOADED SHELLS OR CARTRIDGES</b>	If unfired ammunition is recovered in investigation, forward to Laboratory. If ammunition manufacturer's boxes are recovered, forward to Laboratory for latent print examination.	Sketch showing relative position of shells or cartridges collected from scene. Transmit a copy of this information to the Laboratory.

<b>SHOT OR POWDER PATTERNS</b>	If on clothing send only the clothing that might contain powder, powder residues, or exhibit bullet or shot penetrations. If on skin, doors, walls, etc., consult Laboratory concerning scaled photographs.	Description and source of garment containing shot or powder patterns. Location and size of shot or powder patterns on walls, doors, or other immovable objects.
--------------------------------	---	---

### Instructions for Handling, Marking, and Shipping Firearms Exhibits

<b>RECOMMENDED METHOD OF PACKAGING, MARKING FOR IDENTIFICATION AND SHIPPING TO THE LABORATORY</b>	<b>EXHIBIT</b>
Attach an ID tag and mark tag with initials, case #, date and item #. Secure firearms and magazines to cardboard box or rigid container with fasteners. Package each cartridge separately in a cardboard box or rigid container and mark containers according to your sketch. Seal the package, initial the seal, and label each container with case #, date, item # and source. Forward to Laboratory along with the descriptive record.	<b>FIREARMS</b>
Package each separately in cardboard slide box or rigid container. Do not put in envelope. Mark on the container the source of each bullet. Seal the package, initial the seal, and label each container with case #, date, item # and source. Forward to Laboratory along with the descriptive record.	<b>FIRED BULLETS</b>
Package each separately in cardboard slide box or rigid container. Seal the package, initial the seal, and label each container with case #, date, item # and source. Forward to the Laboratory along with the descriptive record.	<b>FIRED METALLIC CARTRIDGE CASES</b>
Same as above.	<b>FIRED SHOT SHELLS</b>
Same as above (all of the available fired shot can go in a single box).	<b>SHOT PELLETS</b>
Same as above.	<b>SHOT WADS</b>
Same as above.	<b>LOADED SHELLS OR CARTRIDGES</b>
Place each individual air-dried item of clothing in a separate clean paper bag. Seal each bag, initial each seal and label each bag with case #, date, item # and source. Forward to the Laboratory along with the descriptive record.	<b>SHOT OR POWDER PATTERNS</b>

## IV. Bullet Path Reconstruction

Defining a bullet path at a shooting scene is a useful element of crime scene reconstruction. A shooter's position and final bullet location can both be defined by determining the path of a bullet or bullets through a sequence of materials. Such reconstructions are most accurate when a bullet has created both a bullet hole and a subsequent impact site or two or more bullet holes in successive planes of material, e.g. sheet rock on both sides of an interior wall. Inserting rods through the bullet holes (or from bullet hole to impact site) will define a bullet path that can direct the investigator to the shooter's position or to the bullet's likely location (see Figure 10-1). Rods should not be inserted in any bullet hole until documentation and examination of the bullet hole has been completed.

Over short distances, string can be attached to the rods to project the bullet path. This technique is especially useful in reconstructing shootings involving vehicles due to their double-panel construction. However, as the projected bullet path increases in distance from the bullet hole, greater imprecision will be introduced into the reconstruction. For bullet path reconstructions over long distances, a combination of spacer cones, rods and lasers will offer much better precision, especially if meaningful diagramming of the reconstruction is desired.

Unless a bullet passes through a significant thickness of material, a single bullet hole will usually not allow useful reconstruction of the bullet path. However, bullet direction can be determined from through-and-through bullet holes in many materials. For example, the passage of a bullet through metal will create an indentation on the metal surface facing the bullet origin and metal stretch on the surface in the direction away from bullet origin, clearly defining the direction of the bullet through the metal. Bullets that pass through auto glass, skull and some plastics will create a crater on the side of the material away from the bullet origin. In other words the crater opens up in the direction of bullet travel (see Figure 10-2).

Even a portion of a bullet hole in a destructively fractured skull can define the direction of the bullet and subsequently establish exit and entrance. The combination of glass cratering and radial glass fracture in a window can even define the sequence of shots through the window, particularly when working with vehicle shootings.

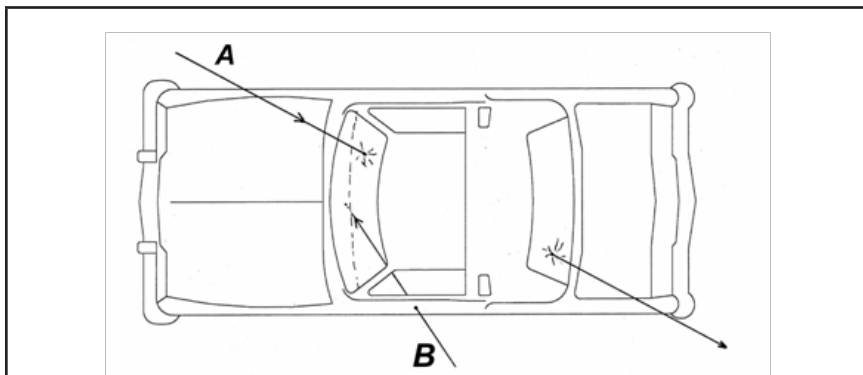

**Fig. 10-1** Bullet paths A&B define two shooter locations outside the vehicle. Such diagrams can be included in crime scene notes to aid in shooting reconstructions.

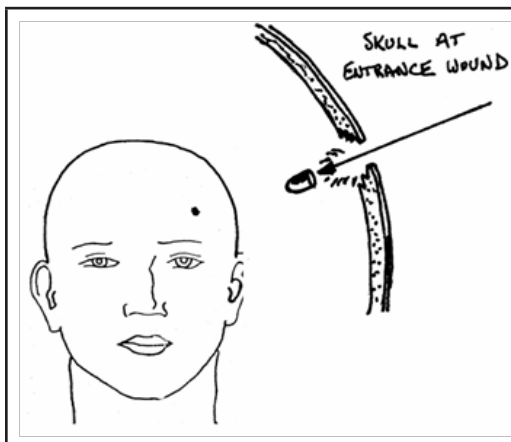

**Fig. 10-2** Note the angled or beveled edges of the skull at the entrance bullet hole. The bone surface through which the bullet passed last will present a cratered appearance

# Notes

## Footwear and Tire Examinations

**F**ootwear (shoe) and tire impression evidence are two of the most valuable pieces of evidence left at crime scenes, however they are often overlooked. If detected, protected, and properly collected, they can be crucial in linking a suspect, or a suspect vehicle to a scene. In some cases, footwear and tire evidence can lead to the identification of which particular known footwear or tire made the impression.

**Note:** As of January 1, 2016, the Wisconsin Crime Laboratory Bureau no longer accepts cases and evidence/standards for Tire Track Analysis. The FBI Crime Laboratory in Quantico has agreed to work Tire Track Analysis cases that would normally be sent to the Wisconsin Crime Laboratory.

For more information on how to submit evidence to the FBI Crime Lab, visit <https://www.fbi.gov/file-repository/handbook-of-forensic-services-pdf/pdf/view>. This link is the FBI Handbook of Forensic Services which provides guidelines and procedures for collecting, preserving, packaging, and shipping evidence to the FBI Crime Lab. Step-by-step guidance is provided. In general, the FBI accepts evidence from state and local law enforcement agencies for cases related to violent crime investigations. The FBI does not routinely accept evidence from state and local law enforcement agencies in cases involving property crimes unless there was personal injury or intent to cause personal injury.

### I. Requesting Footwear Comparisons

Footwear comparisons are typically conducted between a questioned impression and known footwear or standards taken from the known footwear. Standards are generally powdered lifts of known footwear that can be submitted for comparison. However, these are typically only two-dimensional impressions and often do not provide the detail necessary for analysis. **It is important to have the actual footwear to conduct a complete and accurate comparison.**

A questioned impression may be only a small portion of a shoe and does not need to contain the entire length in order for a comparison to be made. The most important factors are the quality of the impression and proper photography of the impression prior to collection.

## Footwear Submissions

1. Submit the **actual footwear** for comparisons as it was recovered (do not clean) & inform lab of the recovery date
2. Submit any standards made from footwear, if taken (*standards should only be submitted in lieu of actual footwear when there is no legal authority or consent to collect them*)
3. Submit the questioned impression(s) (casts, electrostatic lifts, powdered lifts, etc.)
4. Submit all scaled photographic image files of all questioned impressions

**Note:** Suspects may have more than one pair of the same brand and model of footwear. All can be submitted for comparison.

## II. Opinions Rendered By Examiners

The comparison of a questioned footwear impression to known footwear at the Laboratory will result in one of the following opinions:

- Not Suitable for Comparison
- Lacks Sufficient Detail
- High Degree of Association
- Identification
- Exclusion
- Indications of Non-Association
- Limited Association of Class Characteristics
- Association of Class Characteristics



# Footwear and Tire Impressions

**P**roper collection and preservation of footwear and tire impression evidence is essential to capture the detail observed at the crime scene. The choice of collection technique is based on the type of impression:

- Two-dimensional impressions are found on flat, hard surfaces such as wood, tile, or linoleum
- Three-dimensional impressions are found in sand, soil, snow, or other pliable materials

**IMPORTANT NOTE:** Prior to lifting or casting any footwear or tire impression, scaled, take comparison-quality photographs. See [Chapter 2, Forensic Photography](#), VI. Pattern Photography, for detailed instructions.

**NOTE:** As of January 1, 2016, the Wisconsin Crime Laboratory Bureau will no longer be accepting cases and evidence/standards for Tire Track Analysis. The FBI Crime Laboratory in Quantico, VA has agreed to work Tire Track Analysis cases that would normally be sent to Crime Labs in Wisconsin.

For more information on how to submit evidence to the FBI Crime Lab, please call (703)632-8444. Please note that tire tread examination with the FBI is done by the Questioned Documents Unit.

## I. Two-Dimensional Impressions

### Electrostatic Dust Print Lifters

Electrostatic dust print lifters (EDPL) are available from most forensic supply vendors and can be used to collect impressions composed of dust or dry, light, particulate residue from floors, walls, papers, and a variety of other surfaces.

An EDPL consists of a high voltage power supply/control unit, a nickel-plated steel ground plane, and a metalized lifting film. As high voltage is applied to the lifting film, it takes on a negative charge and the ground plane becomes positive. Any dust present under the lifting film will take on a positive charge

## Footwear and Tire Impressions 12

and will then be attracted to the negatively charged collection film. This film retains the charge, preserving the impression, which can then be collected. The film should be taped inside a cardboard box with the IMPRESSION SIDE UP to avoid any movement or contact with any other surface. Lifts taken in this manner will be in a mirrored position and will need to be photographically reversed to return them to their proper orientation.

Consult your EDPL instruction manual and/or the online technical manuals posted by the various EDPL vendors for specific instructions on the use of their equipment.

Additionally, there are now also similar lifting devices that rely on vinyl static cling films rather than high voltage power sources which are available from forensic supply vendors.

**Due to the fragile nature of dust impression(s), scaled, comparison quality photographs should be taken of all static lifts prior to packaging and submission (see [Chapter 2](#)).**

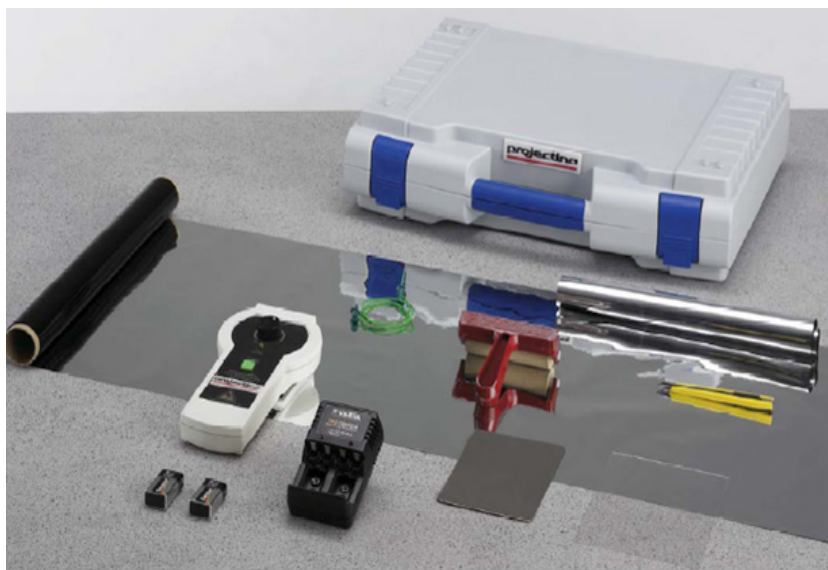

**Fig. 12-1** Hand-held EDPL Kit

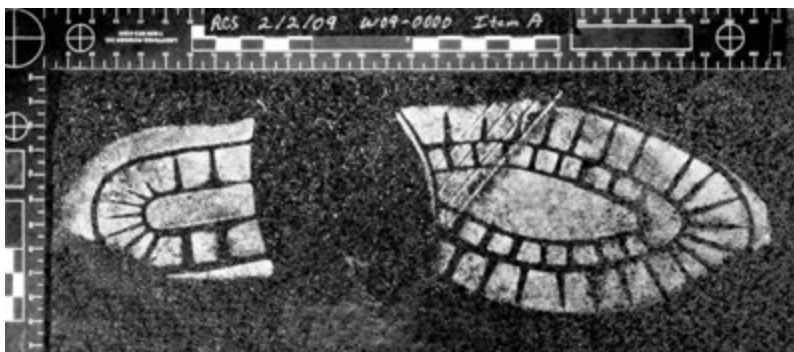

Fig. 12-2 Photograph of an electrostatic lift.

## Gelatin Lifters

Gelatin lifters are a low adhesive lifting device which can be used on almost any visible two-dimensional dust or dirt impression. In addition, gelatin lifters can be used to lift previously wet impressions or impressions developed with fingerprint powder. Gelatin lifters are available in white, black, and transparent and are available in a variety of sizes. Choose a lifter of contrasting color to the impression for optimal results.

**NOTE: Whenever possible, attempt to lift the impression with an EDPL prior to a gelatin lifter for best results.**

Gelatin lifters are used in the following manner:

1. Use a full size lifter or cut to size for partial impressions.
2. Clip one corner of the gelatin lifter before removing the protective cover.
3. Gently place the gelatin lifter over the impression and hold in place with one hand.
4. With the free hand, lightly press or rub the gelatin lifter onto the surface without moving the lifter.
5. Peel back the gelatin lifter.
6. Align the clipped corners, replace the protective cover and label the back of the lift.

Lifts taken in this manner will be in a mirrored position and will need to be photographically reversed to return them to proper

orientation. **Always remove the protective cover** before evaluating or photographing a gelatin lift, being careful not to damage the lift in its unprotected state. Comparison quality photographs may be completed as outlined in [Chapter 2](#). Replace the cover before returning the lift to storage. Gelatin lifts can be packaged in a manner similar to regular latent lifts.

## II. Three-Dimensional Impressions

### What to Cast

While it is preferential to cast all three-dimensional footwear and tire impressions at a scene, it may not always be possible. If it is not feasible to cast all of the impressions, care should be taken to cast the best footwear and tire impression evidence present. Close-up visual examinations of each impression should be conducted to determine which impressions exhibit the best clarity of detail. Oblique lighting from all four sides of each impression can also assist in conducting these visual examinations. Those impressions having the best detail should be marked and preserved for future casting.

*Note: All of the impressions should be photographed properly with a scale prior to any casting that may be done. Refer to [Chapter 2](#) for photographic instructions.*

If there are a large number of impressions at a scene, at minimum, the following should be cast:

- One full footwear impression for each outsole design (*left & right shoe*).
- All full or partial footwear impressions with good detail and clarity.
- One full tire impression for each tire track present (*left front, left rear, right front, and right rear in segments*).
- All partial tire impressions of good detail and clarity.

## Dental Stone Casting Procedures

Dental stone can be used to cast footwear/tire impressions in sand, dirt, or snow. In order to properly cast a footwear/tire impression using dental stone, thoroughly evaluate the substrate, the condition of the substrate, and the environmental conditions. The following are examples of scenarios that may require special considerations:

- Impressions in loose sand or soil may benefit from the use of a hardening agent such as hair spray before casting
- Impressions in snow or ice should be considered a high priority due to the possibility of melting
- A snow or ice impression may benefit from the use of Snow Print Wax™ or gray primer spray prior to casting
- Forms can be used to frame an impression on a steep angle
- A box or shield can be used to protect an impression from rain, snow, sun, wind, etc.

The following materials are needed to cast an impression with dental stone:

- Dental Stone inside a zip top-type bag
  - 2 pounds for an average footwear impression
  - 3 – 4 pounds for one segment of an average tire impression (complete tire rotation is ~ 3 segments)
- Extra Dental Stone
- Approx. 4-6 oz. of water per pound of powder, more may be needed
- Extra zip top plastic bags to protect from leakage when mixing
- Scissors to cut open the bag
- Object to deflect the casting material when pouring into the impression (paint stir stick, fingerprint lift card, etc.)
- Material to help fix the impression before casting (Snow Print Wax™, gray primer spray, hairspray, or hardener)
- Form (cardboard or metal landscape edging) to frame the impression if it is on a steep angle

## Footwear and Tire Impressions 12

- Box or cover to protect impression from weather
- Permanent marker to “mark” cast
- Cardboard box for packaging
- Bowl or bucket if using bulk dental stone
- Stick or spoon for mixing bulk dental stone

Dental stone material can be purchased in premeasured zip-top plastic bags or in bulk amounts. While premeasured bags will be sufficient to cast most footwear impressions, bulk dental stone is often more convenient for casting tire impressions.

### Premeasured Dental Stone

Bags of premeasured dental stone (generally 2 pounds) are available from most forensic suppliers. The primary benefit of the premeasured dental stone is the ability to mix the dental stone in the bag. Premeasured bags of dental stone are easily stored in a scene processing kit along with spare gallon size plastic zip-top bags in the event that a premeasured bag of dental stone leaks during the mixing process.

### Bulk Dental Stone

Bulk dental stone can be measured into gallon size zip-top plastic bags, bowls, or buckets. The size of the bowl or mixing container used can be determined by the size of the impression being cast. One large batch may be used to cast several smaller impressions if done in quick succession. The disadvantages of using bulk dental stone are the space required to maintain the additional equipment and the clean up after use.

### Procedure for Mixing Dental Stone

Dental stone typically requires 4-6 ounces of water per pound of powder to make a mixture the consistency of a **thick paint or pancake batter**. While these are the recommended amounts, the actual amount of water needed can vary based on the temperature of both the water and the environment. **Dental stone should flow freely when poured but should not be watery or runny.**

- Mixing dental stone in a 2-pound premeasured bag:
  - Add a little less than 9 ounces of water to start
  - Squish the bag gently to mix the contents; most have colored dyes in them that will dissipate as the contents mix
  - Make sure that all of the dry material is thoroughly mixed, paying specific attention to the corners of the bag
  - If the consistency is too thick, add more water; If too thin, add more powder
  - Thinner is generally better!



Fig. 12-3 Mixing dental stone in a zip-top bag

- Mixing bulk dental stone in a bucket or bowl:
  - Add water to bucket or bowl (always start with a smaller amount of water than necessary)
  - Slowly add the dental stone to the water, stirring continuously to ensure that it is thoroughly mixed & all of the dry material is incorporated into the mixture
  - If the consistency is too thick, add more water; If too thin, add more powder
  - Thinner is generally better!

In order to properly cast a footwear/tire impression using dental

## Footwear and Tire Impressions 12

stone, thoroughly evaluate the substrate, the condition of the substrate, and the environmental conditions. The following are examples of scenarios that may require special considerations:

- Impressions in loose sand or soil may benefit from the use of a hardening agent such as hair spray before casting
- Impressions in snow or ice should be considered a high priority due to the possibility of melting
- A snow or ice impression may benefit from the use of Snow Print Wax™ or gray primer spray prior to casting
- Forms can be used to frame an impression on a steep angle
- A box or shield can be used to protect an impression from rain, snow, sun, wind, etc.

### **NEVER POUR THE MIXTURE DIRECTLY INTO THE IMPRESSION!**

Use a *deflector* when pouring casting materials into an impression to avoid damaging the impression. Start the pour on the outside of the impression and worked carefully into the impression. If the mixture is too thick or too thin, stop the pour immediately while still outside of the impression and make a new mixture to cast the impression.



**Fig. 12-4** Pouring dental stone using a deflector

Methods and procedures for casting below are provided as guidelines:



## Dry Sand/Soil Conditions:

1. Place scale on the same plane as the detail to be photographed. **Note: Avoid disturbing the impression!**
2. Take comparison quality photographs. See [Chapter 2](#).
3. Carefully remove debris not imbedded in the impression.
4. Re-photograph as indicated above.
5. Stabilize impression with hairspray/hardener if necessary.  
**Note:** *Avoid spraying hairspray directly onto the impression; lightly mist it into the impression. A fine mist pump spray works well. Allow time to dry between applications.*
6. Place a form around the impression if on a steep angle.
7. Pour dental stone mixture on the ground next to the impression or onto a deflector, allowing it to flow into all areas of the impression. In the event that the casting material does not flow completely into the impression, the top surface of the casting material can gently agitated to help it flow. The cast should be of sufficient thickness to avoid breakage (at least 1" thick).
8. Let the impression dry thoroughly (~30-45 minutes, longer in colder weather) before carefully removing it. *Handle the cast very carefully because it is fragile and will break easily.*
9. Mark the cast & package properly.

## Wet Soil Conditions (Submerged or Partially Submerged):

1. Place scale on the same plane as the detail to be photographed. **Note: Avoid disturbing the impression!**
2. Take comparison quality photographs. See [Chapter 2](#).
3. Carefully remove debris not imbedded in the impression.
4. Re-photograph as indicated above.
5. Sift dry dental stone into standing water until absorbed, the water will wick to the top of the dental stone; re-

apply sifted dental stone until all standing water is absorbed.

6. Pour a dental stone mixture over the sifted dental stone to complete the cast.
7. Let the impression dry thoroughly (~30-45 minutes, longer in colder weather) before carefully removing it. *Handle the cast very carefully because it is fragile and will break easily.*
8. Mark cast & package properly.

### III. Casting in Snow and Ice

Dental stone and melted sulfur are the two traditional methods for casting footwear and tire impressions in ice and snow. Because heat is generated by the dental stone as it sets up, it is strongly recommended that one or more layers of Snow Print Wax™ or gray primer spray be added to the impression first to act as a buffer. Do not spray directly onto the impression, but mist over the impression at an oblique angle and allow the spray to fall over it. Apply the spray in light layers, letting each layer dry completely before adding additional layers.

#### Dental Stone/Pour Method

1. Place scale on the same plane as the detail to be photographed. **Note: Avoid disturbing the impression!**
2. Take comparison quality photographs. See [Chapter 2](#).
3. Carefully remove debris not imbedded in the impression.
4. Re-photograph as indicated above.
5. Lightly spray Snow Print Wax™ or gray primer spray to improve contrast (see Figure 10-6).
6. Re-photograph.
7. Spray additional Snow Print Wax™ or primer spray if necessary.
8. Pour the dental stone mixture on the ground next to the impression or onto a deflector, allowing it to flow into all areas of the impression. In the event that the casting

material does not flow completely into the impression, the top surface of the casting material can be gently agitated to help it flow. The cast should be of sufficient thickness to avoid breakage (~ 1" thick).

9. Dry the impression thoroughly (~30-45 minutes, longer in colder weather) before carefully removing it. *Handle the cast very carefully as it is fragile and will break easily.*
10. Mark cast & package proper!



**Fig. 12-5** Impression in snow.



**Fig. 12-6** Impression sprayed with Snow Print Wax™ which enhances the detail of impression and creates a buffer for the dental stone.

## Sulfur Casting

Sulfur is another technique that can be used to cast footwear/tire impressions in snow.

**CAUTION: This technique requires the user be familiar with safety issues regarding the use of sulfur (see sulfur MSDS). The melting of sulfur should be done outside in a well-ventilated area while wearing a dust/mist respiratory mask to prevent the inhalation of sulfur fumes. Adequate ventilation and proper temperature control can also reduce the risk of igniting melting sulfur.**

- the melting point of sulfur is 119 °C
- the flash point of sulfur is 207 °C
- the ignition point of sulfur is 232 °C

The following materials are needed to cast an impression with sulfur:

- Sulfur – powder or prill (pellets)
  - ~ 3 cups for an average footwear impression
- Electric heating mantle or propane stove
- One-gallon unlined paint can
- Large metal spoon
- Material to help fix the impression before casting (Snow Print Wax™, gray primer spray, hairspray, or hardener)
- Form (cardboard or metal landscape edging) to frame the impression if it is on a steep angle
- Box or cover to protect impression from weather
- Permanent marker to “mark” cast
- Cardboard box for packaging

## Heating the Sulfur

Place the sulfur in the paint can and turn the heat to medium to begin melting the sulfur (see Figure 10-7). The sulfur should slowly turn from a yellow solid to a translucent amber liquid. If the temperature of melted sulfur exceeds 160 °C, it will become

a dark, thick syrup at the bottom of the can. This is a sign that sulfur has become too hot and that the temperature should be lowered immediately. Melt until all solids have liquefied. With an effective heating mantle or stove, the sulfur should melt within 10 minutes.

## Cooling the Sulfur

Cool the melted sulfur by stirring it continuously with a large spoon until the sulfur becomes grainy. The sulfur should be a liquid, inelastic gruel, and its color will have lightened. Stir the sulfur constantly as it cools. Do not put the pot in the snow, water, or any place where it will begin to cool quickly. Doing this will cause the sulfur to harden too quickly and you may not have enough time to pour it into the impression. If this occurs, it will require the sulfur to be melted again.



**Fig. 12-7** Heating mantle with one-gallon unlined paint can.

Impressions being cast with liquid sulfur do not require a buffer layer of Snow Print Wax™ to protect them from the heat. However, a light application of Snow Print Wax™ or gray primer spray can be used to enhance the detail in the impression for photography.

Framing of the impression should be considered as liquid sulfur is thin and free flowing. Sulfur does tend to solidify on contact with ice and snow, which will help restrict its movement. The liquid should be poured onto a deflector (spoon) and directed into the impression.

## Procedure:

1. Place scale on the same plane as the detail to be photographed. **Note: Avoid disturbing the impression!**
2. Take comparison quality photographs. See [Chapter 2](#).
3. Carefully remove debris not imbedded in the impression.
4. Re-photograph as indicated above.
5. Lightly spray Snow Print Wax™ or gray primer spray to improve contrast (see Figure 12-6).
6. Re-photograph.
7. Place a form around the impression, if necessary.
8. Heat paint can with sulfur until melted. (See Fig. 12=8)
9. Reduce heat to cool allowing crystals to begin forming



**Fig. 12-8** Cooling sulfur.

10. Pour cooled sulfur fairly quickly from a low height onto a deflector, allowing it to flow into all areas of the impression. (see Figure 12-9). The cast should be of sufficient thickness to avoid breakage (~ 1" thick).
11. Let the cast cool until it is warm (not hot) to the touch (at least 30 minutes) and then carefully lift up the cast from the snow. Do not leave the sulfur cast in the impression for a long time because it can freeze to the ground. Place the cast on a firm surface and **handle the cast very carefully because it is fragile and will break easily**. A layer of dental stone can be added to the back of the cast to prevent breakage. This can be done before or after the sulfur cast is lifted from the impression (see Figure 12-11).

**CAUTION:** Sulfur casts remain *hot* for a period of time after they are poured. Use caution when checking these casts. Do not attempt to lift until the casts have hardened and cooled.



**Fig. 12-9** Sulfur mixture is poured into the footwear impression using a deflector (metal spoon).



**Fig. 12-10** Sulfur cast which has begun to harden.



**Fig. 12-11** Sulfur cast with dental stone reinforcement.



### IV. Marking and Packaging Casts

Once the cast hardens, mark the necessary identifying data on the back of the cast. At a minimum, this should include:

- **case number**
- **exhibit number or location collected (when multiple casts are made)**
- **date**
- **initials of the person making the cast**
- **arrow pointing north to orientate the cast**

Allow the cast to remain undisturbed for a sufficient amount of time to harden. Under dry conditions this may take from 30 minutes to an hour. Drying times will be affected by the consistency of the casting material, the humidity, the moisture content of the ground surface and the air temperature. Casts poured in wet sand and soil *should not* be removed immediately after the exposed portion of the cast has hardened.

Casts should be removed using a gentle rocking motion to avoid breaking the cast. Casts that do not release readily may require the loosening of the dirt underneath the cast. A knife or other bladed object should be inserted into the dirt at an angle allowing the dirt 1" below the cast to be loosened. At no time should the bladed object come into contact with the cast.

**Do not attempt to clean off the cast after removal.** Sand or soil adhering to the cast should not be removed before the cast is completely dry as this may damage the fine details in the cast. Allow the cast to air dry for at least 48 hours before packaging.

To package casts, wrap each separately in paper, **never use plastic**. Seal the cast in an appropriately sized box with enough packaging material to protect it from damage. Each cast should be sealed in a separate box.

Moisture may exude from a dental stone cast for several days thereby weakening bags and boxes used as packaging. Check the integrity of the packaging at the end of the drying stage. Repackaging may be necessary once the cast is completely dry.



# Latent Prints

*Friction ridge detail from the fingers, palms, and feet has been a valuable method of personal identification in forensic science and criminal investigations for more than 100 years. One of the most significant benefits of this evidence is that it can establish an individual's presence at a crime scene or contact with an object.*

*Friction ridge evidence is most significant when the person identified had no lawful presence where the print was found or no lawful contact with the object touched. It is the totality of the circumstances, established through an investigation, which determines the significance of a friction ridge identification in a court of law.*

## I. Friction Ridge Overview

Friction ridge impressions can be categorized as follows:

- Latent prints – invisible or hidden
- Patent prints – visible prints
- Plastic prints – 3-dimensional impressions

**Latent prints** are prints that require physical or chemical enhancement for collection. The processes used to recover latent prints are routinely determined by the surface of the object on which the latent prints are deposited and the condition of that surface. These surfaces can be divided into four general categories:

**Non-porous** – surface does not absorb water: glass, metals, plastics

**Porous** – surface absorbs water: paper, cardboard, wood

**Semi-porous** – shiny surface which may absorb water: glossy papers, printed boxes

**Sticky surfaces** – surface with an adhesive side: tapes, labels, stamps

**Patent prints** are visible prints typically resulting from a foreign substance such as blood, dirt, ink, paint, etc. These types of prints are first preserved through photography with a scale. Once these prints are captured photographically, the items may be processed as for latent prints based on the surface type.

**Plastic prints**, like patent prints, are visible prints usually impressed into a medium such as dust, dirt, clay, wax, soap, paint, etc. Plastic prints are first preserved through photography with a scale and then may be recovered with silicone-type casting materials.

## II. Locating Friction Ridge Evidence

Even though all objects at a crime scene could be viewed as a possible source of friction ridge detail, it would be impractical, if not impossible, to process everything. When processing for friction ridge detail, the following should be considered:

- Which objects were likely to have been touched by the suspect(s)?
- Were any objects left behind at the scene?
- Will prints on the object be probative to the investigation?

This evaluation process can save valuable time at a crime scene and at the Laboratory, allowing time and resources to be directed toward items of evidentiary value.

Deciding what to process within the scene should be done systematically. Try to reconstruct the suspect's movements outside and inside the scene if possible. Determining the following may also be helpful in locating valuable evidence linking the suspect to the scene:

- Points of entry and exit – doors, door frames, door knobs, windows, screen and window frames, broken glass, or tools used to gain entry
- Points of attack – areas where items have been disturbed, damaged or removed

- Areas of restricted movement – narrow hallways, stairways and cluttered areas may result in inadvertent touching of walls, handrails and other obstructions

Once it is determined what items are to be processed for prints, any fragile or transient evidence should be considered first. Each item should be evaluated separately as to the following:

- Can the item be collected or must it be processed at the scene?
- What are the recommended processing techniques?
- Do I have the necessary equipment to complete the processing?
- Will processing for prints likely destroy other evidence that may be present?

The question, “Can the evidence be collected or must it be processed at the scene?” is a particularly important element to effective crime scene management. While it is not required to collect evidence for future processing, it is a practical recommendation to avoid being overwhelmed at the scene. Collecting scene evidence for future processing may also provide:

- A more conducive work environment for evaluating and examining evidence
- Time to effectively complete the processing and to consult reference materials
- The availability of additional equipment and/or technical assistance

The items collected for future processing should be handled carefully. Avoid unnecessary handling as even gloved hands can destroy prints or dislodge other evidence. If DNA (see [Chapter 6 - DNA Evidence and Standards](#)) is a consideration, be sure to change gloves as needed. Items collected should be packaged following the recommendations outlined in [Chapter 1](#) of this handbook.

## Visual Exams

Nondestructive visual examinations should always be done prior to processing. The use of a magnifier, aided by oblique lighting with a flashlight can facilitate the discovery of visible prints. Visual exams can also facilitate the discovery of other evidence not readily seen by casual observation: trace materials, hairs, fibers, biological stains, etc.

Document the location of any evidence observed during visual examinations and perform the appropriate recovery technique. Friction ridge impressions observed during visual exams should be photographed **with a scale** (see [Chapter 2](#)) prior to using physical or chemical processing techniques.

The use of an alternate (forensic) light source (ALS) or portable laser may also be of benefit to visualize friction ridge impressions and other evidence before processing.

## III. Processing

### Superglue Fuming

Superglue (cyanoacrylate) fuming is a highly effective technique for developing friction ridge detail on *non-porous* surfaces. Superglue fumes adhere to latent print residue and make the prints more durable and less likely to be damaged or obliterated. These developed prints can then be enhanced using powder or fluorescent dye stains. Superglue fuming is recommended:

- if items are to be stored for long periods of time prior to processing and
- **before** fingerprint powders are used

The effectiveness of the superglue process is dependent on variables such as ambient temperature and humidity, the

container being used to process the items, and the length of time the items are fumed.

The superglue process is a relatively simple technique. A typical setup is shown in Figure 13-2. The equipment needed includes:

- an **airtight** chamber such as an aquarium
- superglue (pouches or liquid) – *make sure it contains cyanoacrylate* (some store brands do not)
- hot water to increase humidity
- a hot plate (if using liquid superglue) and a non-melting container to hold the superglue (foil is recommended)
- a method of suspending items such as plastic baggies in the chamber

**NOTE: SUPERGLUE FUMES ARE EXTREMELY DANGEROUS! Use this process only in well ventilated areas such as an exhaust hood or a large open area to avoid inhaling superglue fumes.**



**Fig. 13-1** Example of a typical superglue fuming chamber. (A) is a piece of wire from which items can be suspended. (B) is a beaker of hot water. (C) is a mug warmer to heat liquid superglue on a piece of foil.

**NOTE: If superglue pouches are used, the hot plate is not necessary.**

### **Superglue fuming procedure:**

1. Place the evidence into the chamber, making sure all surfaces of the items are exposed to the fumes
2. Put superglue (on a hot plate if necessary) and water into an airtight chamber

3. Monitor fuming development
4. **Properly ventilate the chamber before removing evidence**

**Continuously monitor the superglue development of latent prints to ensure that the items are not over-processed.** Depending on the size of the fuming container, items may be processed in as little as 5 minutes, so be sure to stop fuming once any indication of a white film is detected. A flashlight and a test print on a dark or shiny surface may help to visualize the development. It is always better to under-process than to over-process!

### Latent Print Powders

*Non-porous* surfaces can be dusted with fingerprint powders to assist in locating and enhancing friction ridge detail.

**NOTE:** *When items are removed from the scene for later processing, it is recommended that the nonporous items be processed with superglue (cyanoacrylate) prior to using any powders. The superglue process will make impressions more durable and less likely to be damaged during shipping or transportation to the Laboratory. In addition, further processing with chemical techniques and ALS/laser examination to develop and enhance any latent prints that are present can be performed at the Laboratory. Fingerprint powder interferes with these chemical techniques if the item was not initially processed with superglue.*

Either traditional or magnetic powder can be used on most non-porous surfaces. Powders should be applied using the following guidelines:

- Use black powder as often as possible; black powder can even be used on dark surfaces
- Apply gently and evenly using the least amount of powder necessary; it is best to start with less powder and add more powder as needed
- Apply powder carefully with a circular-type motion; **do not**

**brush across the ridges!**

- Evaluate continuously until desired contrast is obtained
- Stop processing if it damages the prints or the contrast diminishes
- Clean the developed prints to remove excess powder and to provide maximum clarity of detail (see Fig. 13-2)



**Fig. 13-2** Failing to clean a print before lifting can result in air bubbles and powder debris voids.

The following cleaning techniques can improve the quality and clarity of powdered prints by removing excess powder:

- Very carefully use a powder-free detail brush to follow the flow of the ridges of the print
- Gently tap the item on its edge

## Porous & Semi-porous Items

Porous items should not be processed with powders, but should be collected for chemical processing. While it may be possible to develop prints through the use of powders on some semi-porous items, *it is not recommended for optimal development*. Chemical techniques are available which may provide better results on these items. If you have any additional questions about porous and semi-porous items, please contact the Laboratory.

## IV. Recovery

### Photography

**All visible, superglued, and powdered prints should be photographed with a scale prior to packaging or further processing.** Powdered prints should always be photographed with a scale before attempting to lift them. Both mid-range and close-up photographs should be taken. **Mid-range photographs** document the location of the developed prints while **close-up photographs** provide the needed detail for comparisons. **Close-up photographs** should be taken as follows:

- Camera mounted on a tripod for stability
- Use a macro or near macro lens
- Prints should be photographed individually, filling the viewfinder, with the scale increments present in the image (see Fig. 13-3)
- The scale should be placed on the same plane as the print

Refer to [Chapter 2](#) for more details on how to photograph impression evidence.



**Fig. 13-3** Measurement increments should be visible in the photo to show whether they are in mm, cm, or inches.

### Lifts



**Lifts** are primarily made with clear tape of various widths placed onto backing cards. Gel/rubber lifters, gel tapes, or casting materials such as Mikrosil may be used in lieu of tape for rough or textured surfaces (see Fig. 13-4). Choose the lifting material that will provide the best coverage and remove all of the print from the surface. A test lift can be attempted using an area of the surface without an evidentiary print to determine what lift method may work best.

Multiple lifts of the same impression can be made if the print can still be visualized after the first lift. This is especially true if the item has been processed with superglue first. The initial lift may clear away debris improving detail in the impression resulting in a second, better quality lift. When duplicate lifts are made, they should be clearly marked as such to avoid confusion during comparisons. Whenever possible, simultaneous finger impressions and palm prints should be lifted as one lift to assist in comparisons.

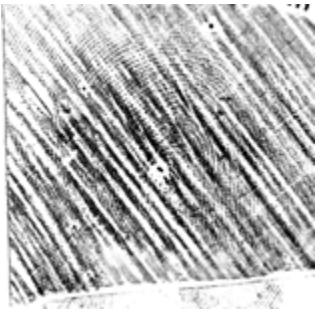

**Fig. 13-4** Standard lifting tape on textured or rough surfaces can result in voids. Gel tapes, gel lifters, and casting materials which are more flexible can be used in an attempt to eliminate these voids. **NOTE: Lifting should be attempted ONLY after scaled photography.**

Tape lifts should be placed on a **transparent acetate sheet** or a **card of a contrasting color** to the powder used. Transparent sheets are strongly recommended when lifting prints that are difficult to see due to a lack of contrast, such as those dusted with white

or grey powder, though transparent cards can be used for all prints.

## Lifting Method

Pull a length of tape sufficient to cover the area to be lifted from the roll in a single motion. The tape can remain attached to the roll for stability or can be cut from the roll if more flexibility is needed. When cutting the tape from the roll, either before or after lifting, it is advisable to leave a **leader** for future use. One way to produce a leader is to fold over the end of the tape after each cut. Another method is shown in Figure 13-5.

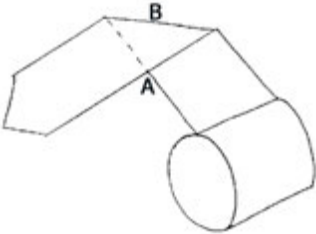

**Fig. 13-5** Cutting the tape from A to B will leave a leader for the end of the roll and for the piece used for the lift.

Secure the end of the tape on the surface *without* covering the print(s) to be lifted to insure the tape will not buckle (see Figure 13-6). Keeping the tape above the surface, slowly smooth the tape across the print(s) with your fingers until the print is covered (see Fig. 13-7). Minimize or eliminate any resulting air bubbles or debris voids by rubbing with the flat surface of your fingernail. Larger air bubbles can be eliminated by first poking a small hole in the tape before smoothing with your fingernail.



**Fig. 13-6** While keeping the tape off the evidence, one end of the tape is anchored at a point beyond the latent prints to be lifted.



**Fig. 13-7** Smooth the tape over the suitable latent prints from one end to the other in a continuous motion eliminating air bubbles.

*Training and experience is encouraged before working on case evidence to become more comfortable with these techniques*

**NOTE:** Do not discard any lift in which ridge detail is observed. The identification of a fingerprint can involve a relatively small area with limited detail.

## V. Marking the Lift

After making the lift, it should be immediately marked for identification purposes (see Figure 13-8). The information recorded should include:

- Case number
- Date collected
- Item lift was collected from
- Name of the individual making lift
- A small sketch of the item on the back of the lift card with a mark orientating the location of the lift for future reference and court documentation.



**Fig. 13-8** Information that should be completed on the back of a latent lift card.

Avoid placing circles or arrows on the lift tape to indicate where latent prints were observed. These markings often cover prints of weaker contrast. However, you should “X” out any friction ridge detail known to be deposited on the tape by the person making the lift (see Figure 13-9). Any other markings should be placed on the lifting card, not on the tape.



**Fig. 13-9** “X” out any friction ridge detail known to be deposited on the tape by the person making the lift.

**Contact the Identification Unit in your service area if you have any questions regarding the information contained in this chapter.**

# Major Case Prints

**T**he purpose of major case prints is to record all of the friction ridge detail on the hands so that complete finger and palm print comparisons can be completed. This includes the fingers, fingertips, finger joints and edges of the fingers as well as the entire palm. **Major case prints should be taken of all felony suspects and victims of homicide.**

Major case prints were traditionally taken by inking all friction ridge skin on the palmar surface of the hands and transferring the detail to a white card (ink method). In more recent years, the powder and tape method has been used and is the preferred method at the Laboratory. Both methods are addressed in this chapter.

## I. Powder & Tape Method

### Equipment Needed

- Black powder (*traditional or magnetic*)
- 1.5" – 2" & 4" clear tape (flexible polyethylene tape works well)
- Fingerprint brush or magnetic applicator
- 8" x 10" or larger clear acetate sheets



Fig. 14-1 Equipment

### Recording the Fingers

1. Black fingerprint powder is lightly applied to all surfaces of the fingers and palms (see Fig. 14-2). **Note: A very light application of powder works best.**
2. Using a 2 - 3 inch length of clear 1.5" – 2" tape, begin at the tip of the finger and attach the end of the tape to the nail bed. **Be sure to leave enough tape to wrap around the sides of the tip and the finger.**
3. Smooth the tape down the length of the finger towards the palm (see Fig. 14-3).
4. Release the top edge of the tape from the nail bed and

## Major Case Prints 14

smooth the edges of the tape around the tip and sides to cover all of the ridge detail. Make sure to press the tape into all areas of the tip as it starts to fold.

5. The tape is then lifted and attached to the clear acetate
6. Be sure to label each fingerprint on the acetate and repeat the above procedure until all fingers have been clearly recorded. (See Fig. 14-4)



**Fig. 14-2** Lightly dust fingers with black powder.



**Fig 14-3** The dusted finger with tape attached. Be sure to cover the very tip and sides of the finger. Run the tape carefully down towards the palm.

**Note:** It is sometimes difficult to record all of the friction ridge detail from the fingers in one lift, particularly the tips. Be sure to examine your lift and note any missing areas so they can be recorded with an additional lift(s). This lift(s) can be added to the same clear acetate sheet if space allows.



**Fig. 14-4** Attach the tape to clear acetate. Be sure to label each fingerprint.

**Note:** Friction ridge detail recorded using tape is in a reversed position when attached to acetate so be sure to label it accurately.

## Recording the Palms

1. Lightly brush the palms in the same manner as the fingers (see Fig. 14-5).
2. Using 4" tape, smooth the tape onto the palm from the bottom of the fingers to the wrist. **Note:** You can also use 2 or 3 strips of 1.5" - 2" tape in overlapping strips to cover the entire palm (see Fig. 14-6).
3. Any areas not covered by the tape can be covered with additional overlapping tape. The tape should overlap enough to allow the removal of all pieces of tape as one lift.
4. Be sure to wrap the ends of the tape over the edges of the palm so that all friction ridge detail is recorded.
5. Care should be taken depositing the lift onto the clear acetate to avoid creases (see Fig. 14-7).



**Fig. 14-5** Lightly dust the palm with black powder.



**Fig. 14-6** Smooth strips of 1.5" to 2" tape (or 4" tape) over palm, covering the entire area from the bottom of the fingers to the wrist.



**Fig. 14-7** Attach tape to clear acetate taking care to avoid creases.

*This process is **repeated** until clear and legible prints are obtained for all ridge detail of the fingers and palms.*

### **Benefits of the Powder and Tape Method**

1. Less time to complete than inked major case prints.
2. Limited clean up.
3. Powder covers ridge detail more evenly.
4. No rolling of fingers or palms to cause smearing.
5. Gives greater detail in one recording.





**Fig. 14-8** Equipment needed for the ink method

## II. Ink Method

### Equipment Needed

Standard tenprint/palm print cards (8" x 8") or other clean white recording surface

- A roller for spreading ink on the fingers and hands
- Black printers ink
- A cylinder, 3" or more in diameter for rolling palms

### Recording the Fingers

1. The first step to taking major case prints is to roll a standard tenprint card (see Fig. 14-9). Each finger should be rolled from nail edge to nail edge to obtain the entire width of the pattern area. Care should be taken to also include as much of the tip and the first crease as possible.



**Fig. 14-9** Tenprint card with properly recorded inked prints.

## Major Case Prints 14

2. After the tenprint card has been properly recorded, the entire finger is then inked for recording the inner, middle, and outer edges, and the tip of each finger. This step will require the use of at least two 8" x 8" cards (see Figures 14-10 and 14-11).
3. Starting with the thumb, the outer edge or side of the inked thumb is placed on the card and rolled 45° inward towards the middle.
4. The middle area of the thumb is then placed on the card next to the rolled outer edge.
5. The inner edge of the thumb is recorded in the same manner as the outer edge.
6. The thumb is then completed by recording the tip area, placing it on another sheet (as in Figure 14-11) or above the previously recorded edge areas.
7. **Be sure to label each finger on the acetate and repeat the above procedure until all fingers have been clearly recorded.**



**Fig. 14-10 and Fig 14-11** Outer, middle, and inner edges of fingers and thumbs  
Rolled tips of fingers and thumbs

### Recording the Palms

1. Attach an 8"x8" card to the cylinder using rubber bands on each end to avoid movement during rolling.
2. Apply a thin layer of ink to the palm and fingers (see Figure 14-12).

3. Roll the hand onto the 8" x 8" card attached to the cylinder. The wrist area of the palm is placed onto the bottom edge of the card and rolled gently backwards towards the body (see Figure 14-13). A hand placed on the back of the palm, using a slight downward pressure, will help ensure the entire palm is recorded properly.
4. The outer edge of the palm is then recorded on the card (see Figure 14-14).
5. The palm is completed by rolling the inner edge of the palm on the card (see Figure 14-15).

**This process is repeated until all friction detail is recorded and the prints are clear and legible (see Figure 14-16).**



**Fig. 14-12** Ink the palm and fingers with a thin uniform coat.



**Fig. 14-13** Place the palm of the hand on the cylinder and roll the hand to the fingertips maintaining pressure on the hand.



**Fig. 14-14 and Fig. 14-15** The outer edge of the palm is recorded, and the inner edge of the palm is recorded.

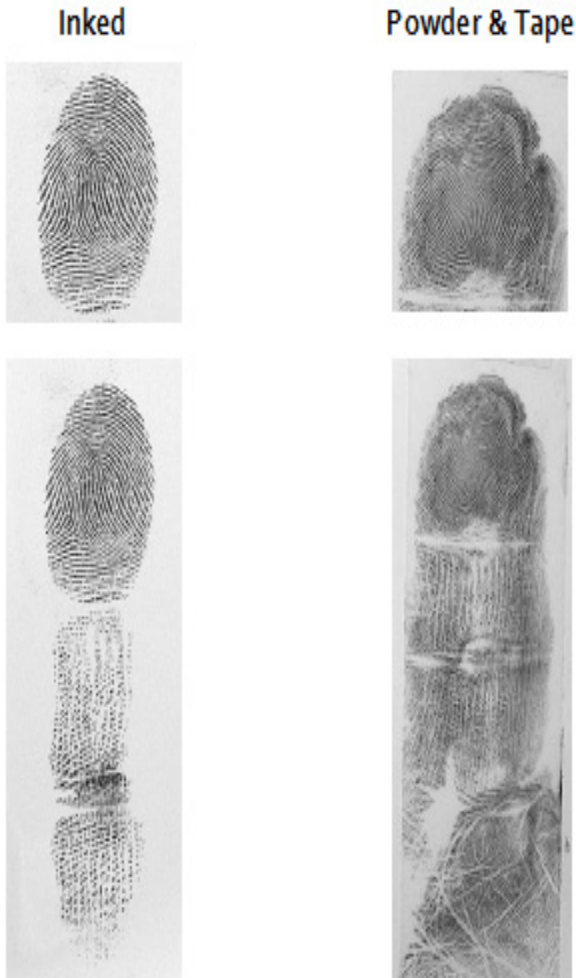

**Fig.14-16** Ridge detail of the palm is recorded from the base of the palm to the fingertips and both the inner and outer edges of the palm. A sheet of paper can be used to protect the rest of the document when recording the inner and outer edges of the palm.

### Drawbacks of the Ink Method

1. Hard to apply an even coating of ink to all areas of hands and fingers can produce uneven results.
2. Rolling of hand often introduces slippage – duplicate cards must be taken until documented properly.
3. Requires equipment not always available to the scene technician.
4. Movement can affect the quality of the prints.
5. Can take 45 minutes to an hour to complete.

## Examples Illustrating the Two Methods



**Fig.14-17** Results Example of Inked Method and Powder Tape Method

**Note:** The powder/tape method results in a larger amount of clear detail from all areas of the fingers and the palms and generally allows for more complete comparisons.

# Notes

# Automated Fingerprint Identification System (AFIS)

**T**he AFIS is a computer-based system for cataloging, searching, matching, and storing known finger and palm prints, latent prints, and related demographic data. It is able to acquire, digitize, process, store, and retrieve known finger and palm print images from arrest and applicant records, and latent finger and palm evidence images. The AFIS compares finger and palm prints and locates possible matches based on corresponding minutiae (ridge endings and bifurcations). Known finger and palm prints processing is done to establish positive identification and for creating/updating criminal history records. Latent finger and palm prints can be searched against the known records for potential matches, and saved for search against all incoming records. As the State's central repository for fingerprint records associated with arrests, the AFIS interfaces with the FBI's Next Generation Identification System (NGI). It gives Wisconsin law enforcement agencies access to nationwide criminal justice information.

## I. American National Standards Institute/National Institute of Standards and Technology (ANSI/NIST) Record

Finger and palm prints of subjects arrested or taken into custody at booking facilities throughout the state are typically captured electronically with a livescan device. This electronic capture creates an ANSI/NIST record which is the electronic format used by the state and FBI for processing arrest and applicant record in the AFIS. The ANSI/NIST record includes:

<b>Type-1 Record</b>	<b>Transaction Record – File Header</b>
<b>Type-2 Record</b>	<b>User Defined Text Record</b>
<b>Type-4 Record</b>	<b>High Resolution Gray Scale Record</b>
<b>Type-7 Record</b>	<b>User Defined Image Record</b>
<b>Type-10 Record</b>	<b>Facial Image Record</b>
<b>Type-13 Record</b>	<b>Variable Resolution Latent Image Record</b>
<b>Type-14 Record</b>	<b>Variable Resolution Ten Print Image Record</b>



## Type-15 Record    Variable Resolution Palm Print Image Record

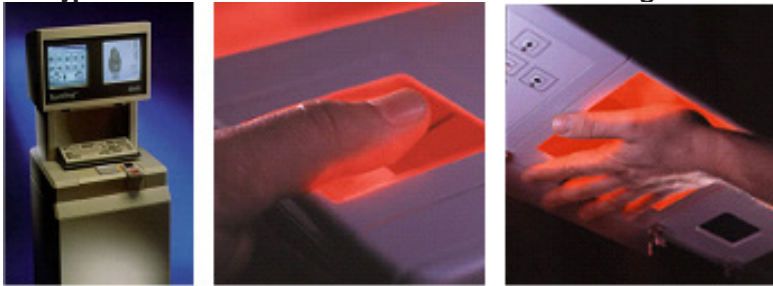

Fig. 15-1 AFIS terminal

Finger Scan

Palm Scan

## II. Image Capture – Taking Legible Fingerprints and Palm Prints

"Fingerprints" is a general term for the friction ridge skin located on the hands and feet of every person. Friction ridge skin consists of raised ridges and valleys on the gripping surface of the hands and feet. In fingers and toes, these ridges form patterns of loops, whorls, and arches. These patterns are the result of the flow of the ridges, and are formed in utero. The ridges split (bifurcate) and terminate (end) in random ways; the location and spatial relationships of these changes in the ridges are different in every finger and palm print, and are what makes them unique and identifiable. A good fingerprint image is an image that provides sufficient data to accurately identify the pattern and the changes on the ridges.

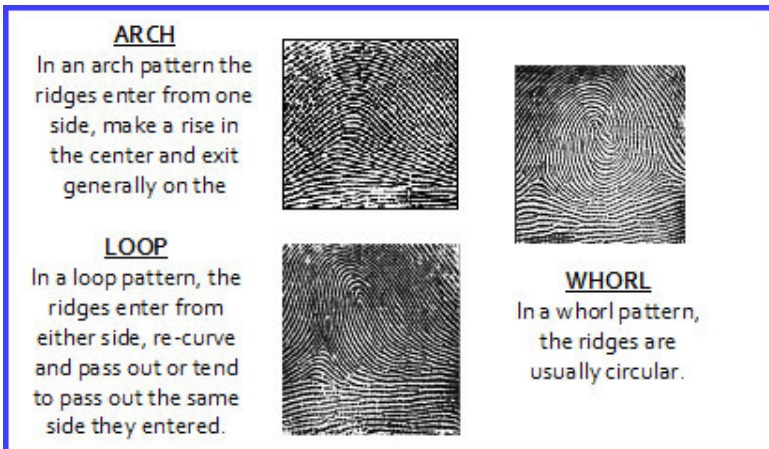

Fig. 15-2 Fingerprint Ridge Patterns



When capturing prints for a fingerprint card, there are two types of impressions. The first is called a **rolled** impression. These are the ten individually collected impressions in the upper half of the collection area. They are referred to as rolled impressions because the fingers are rolled nail-to-nail (side-to-side) to obtain all available ridge detail.



**Fig. 15-3** Rolled and Plain Impressions

The second type of fingerprint impressions are called **plain** impressions; these are also referred to as “slaps” or “flats.” These impressions are located in the four boxes at the bottom of the fingerprint card. These are not rolled, but are laid down in a single up-and-down motion. The fingers of each hand are printed simultaneously at a forty-five degree angle to ensure proper positioning. Plain impressions are used to verify the sequence and accuracy of the rolled impressions.

### **Basic Fingerprinting Equipment**

Fingerprints can be recorded with any of the following materials:

- Livescan – Electronic capture of fingerprints and palm prints. For a list of FBI Certified livescan and cardscan devices go to <https://www.fbibiospecs.cjis.gov/Certifications>. Agencies should follow the Electronic Biometric Transmission Specifications Manual (EBTS).

- Black Printers Ink or Porelon Pads (contains a built-in ink supply) and an 8 x 8 standard paper fingerprint card (WI DJ-LE-24, FD-249 criminal card or FD-258 applicant card).
- Postmortem Kit (Special equipment or fingerprint spoon used when fingerprinting deceased subjects or those with deformities. This can be used with fingerprint card strips or retabs. If using the ink and paper method, retabs may be used to reprint fingerprints (can only use one per fingerprint block).

### **Suggestions for Taking Legible Fingerprints**

- Ensure that the person collecting the prints has been trained to use the proper techniques and procedures for taking legible fingerprints.
- Recommended height for the fingerprint capture device is thirty-nine inches from the floor. This will allow the forearm of an average adult to be parallel to the floor, which is the best position to roll fingerprints. If the fingerprinting device is not at this height, additional care must be taken as the fingers may rise off the device, causing incomplete capture of the ridge detail.
  - Fingers and palms must be clean and dry. Fingers/palms can be wiped with alcohol pads and dried to prevent interference from perspiration.
  - An individual's occupation or age may cause difficulty in capturing clear fingerprint images. If an excessive amount of creases/wrinkles are present in the images, use a softening agent (lotion) or ridge builder to enhance the ridge detail.

### **Steps for Fingerprinting**

- The individual being printed should stand to the right and rear of the person taking the fingerprints and directly in front of the fingerprint stand at forearm's length from the fingerprinting device.
- Encourage the individual being fingerprinted to relax and look at some distant object which may distract them from what you are doing.
- Grasp the individual's right hand at the base of the thumb

with your right hand. Guide the finger being printed with your left hand, cupping your hand over the individual's other fingers.



**Fig. 15-4** Finger Inking for Impression

- If using the ink and paper method, roll the finger on the inking plate or porelon pad so the entire fingerprint area is evenly covered with ink. The ink should be rolled from nail-to-nail and from crease of the first joint to the tip of the finger as seen in the pictures above. Using the right amount of ink is of vital importance. Too little ink and the impression will be too light. Too much ink and the fine details will run together.
- To collect rolled impressions, the side of the finger is placed upon the paper fingerprint card (in the correct space) or the livescan platen, and the finger is rolled across in an even and controlled manner to the other side of the finger, capturing the detail from the tip to the first joint. Lift each finger up and away after rolling to avoid smudging. Generally, the weight of the finger is all the pressure needed to clearly record the fingerprint.
- In order to take advantage of the natural movement of the forearm, the hand should be rotated from the more difficult position to the easiest position. This requires that the thumbs be rolled toward and the fingers away from the center of the individual's body. This process relieves strain and leaves the fingers relaxed when rolling so that they may be lifted easily without the danger of slip, which smudges and blurs the fingerprints.
- If using the ink and paper method and a rolled impression

is not acceptable, you may use an adhesive retab to cover that fingerprint. (No more than one retab per finger block is permitted.) For livescan, the image can be deleted and retaken.

- Plain impressions are printed last, at the bottom of the card. The technician simultaneously places the individual's four fingers, keeping the fingers together, on the surface of the fingerprint card or the fingerprinting device at a forty-five degree angle in order to capture all four fingers in the allotted space. Repeat this process for both hands. Print each thumb individually in their allotted space (both thumbs can be printed simultaneously to prevent mix-up).
- If using the ink and paper method, complete the information at the top of the fingerprint card. If using livescan, complete the required information.

### **Additional Information for Livescan Collection**

- **Always make sure the livescan platen is clean and scratch free.**  
A build up of oils, dirt, and old prints on the glass platen and a scratched or damaged platen can cause the captured image to be of poor quality.
- **Always center the finger when rolling.**  
This will ensure that the image is in the middle of the fingerprint block and thus will allow capture of the most ridge detail.
- **Always leave the livescan image quality and sequential settings turned on.**  
This will ensure that the fingerprint images that are being captured are the best quality possible and that they are in the correct position on the fingerprint card. Ignoring the quality or sequence warnings on your device, may result in rejection of your record and may result in a request for recollection.
- **Always view the images on screen during capture for clarity and orientation of prints. Too much pressure and/or not enough pressure** can alter the image of the captured print. The livescan operator should also check to confirm the rolled impression is oriented upright and not tilted.
- **Always roll fingers from nail-to-nail.**  
This will ensure that as much ridge detail as possible is captured. This also will increase the likelihood of a possible match on an AFIS search for both ten prints and latent prints.

- **Always make sure that the livescan equipment receives regular cleanings, maintenance, calibration, and is in compliance with current standards for image compression.**

### III. Image Quality

Obtaining high quality impressions on finger and palm print cards can be best achieved through continued practice combined with the right equipment, its proper installation, and knowledge of how to use it. Each fingerprint and/or palm print coming into the state's AFIS goes to an automated coder that places minutiae markers on ridge endings and bifurcations. Accurate placement of these markers depends on the clarity/quality of the image. Proper placement of these minutiae markers increases search accuracy for all types of AFIS searches. The types of searches performed on the state's AFIS today includes ten print-to-ten print, ten print-to-unsolved latent, palm print-to-unsolved latent, unsolved latent finger-to-ten print, unsolved latent palm-to-palm print, and 2-Finger Fast-ID.

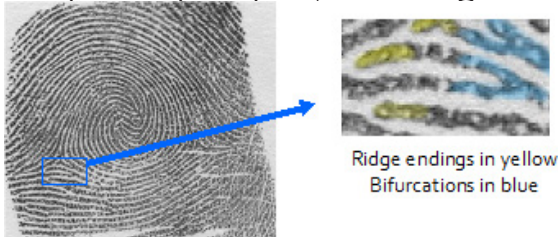

**Fig. 15-5** Example of proper marker placement

Booking officers should always review each finger and palm print image during the capture process to ensure that only high quality prints are submitted to the Wisconsin Department of Justice (DOJ). A high quality AFIS database will aid law enforcement in solving more crime. The following fingerprint images are examples of high quality, clear, completely rolled prints. The ridges are clearly defined, with good contrast, and the prints are evenly rolled.



**Fig. 15-6** High Quality Rolled Print Example

**Finger and palm print images of low quality and clarity may be rejected, and recollection may be required to insert the record into the AFIS.**

Additionally, when fingerprint images are taken improperly and are either smudged or not fully rolled from nail-to-nail, the AFIS coder may place false minutiae on the image which could alter the search results. It is critical that each minutiae marker is accurately set to increase the chances of a match both against known individuals and latent prints. The more information that is stored accurately within the AFIS database, the higher the probability a match may be made.



**Print  
Not Fully  
Rolled Nail  
to Nail**



**Incomplete  
Ridge  
Detail**



**Too much  
Ink and/or  
Pressure  
When  
Rolling**



**Finger  
Orientation  
or  
Placement  
Incorrect**

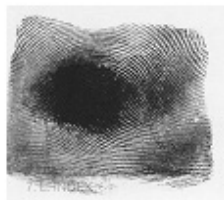

**Poorly  
Captured  
Livescan  
Images**



**Fig. 15-7** Poor Quality Fingerprint Images

During an AFIS ten print search, the AFIS matcher only compares the minutiae markers and the fingerprint pattern. The two images below show a whorl pattern and its minutiae

mapping. It is very important that each ridge within the fingerprint pattern is clear and distinct to allow the AFIS coder to plot each minutiae marker accurately and to establish the pattern type.



*Fingerprint Image*



*Minutiae Mapping*

**Fig. 15-8** Clear and Distinct Image Mapping

### IV. Palm Prints

The state's AFIS has the capability to allow for the capture, search and storage of palm prints. This capability allows for unknown latent palm prints collected from crime scenes to be searched against a known AFIS palm print database. Roughly 30% of latent prints captured from a crime scene are from the palm area of the hand. The techniques used in palm print identification are the same as those used for fingerprint identification. At each arrest, **finger and palm prints** should be captured if possible.

The American National Standard for Information Systems - Data Format for the Interchange of Fingerprint, Facial, and Scar Mark & Tattoo (SMT) Information (ANSI/NIST-ITL 1-2000) has set national standards for the electronic capture and transmission of palm prints, and the Wisconsin DOJ requires that these standards be met. The Federal Bureau of Investigation now requires the submission of "upper palms," consisting of the fingers, finger joints and palm area directly beneath the fingers for submission to their database. While Wisconsin does not require upper palms, our system can accept them and transmit them to the FBI. The Wisconsin Department of Justice will only accept an electronic palm print record if it is sent in conjunction with a ten-print record from the same individual.



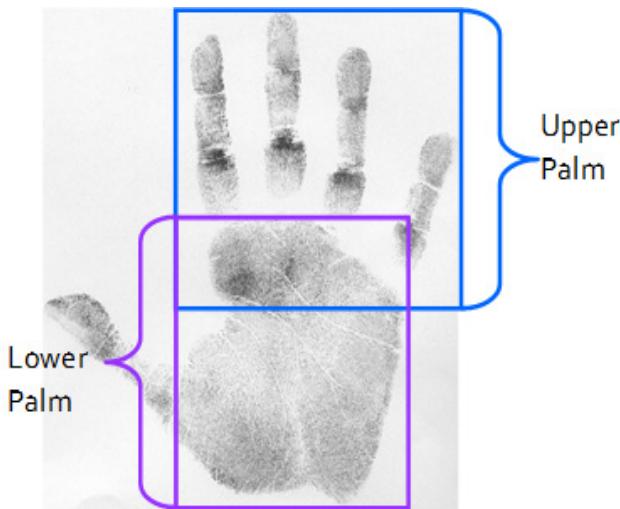

**Fig. 15-9** Upper and Lower Palm Print

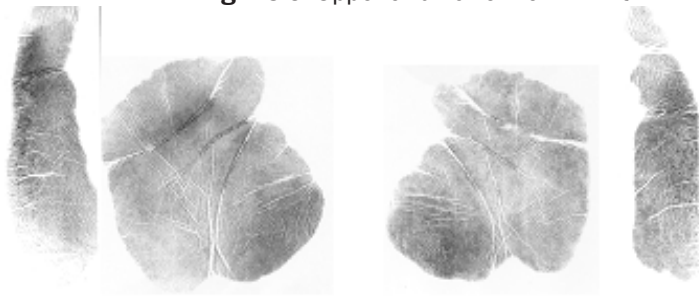

**Left Writer's & Lower Palm    Right Writer's & Lower Palm**

**Fig. 15-10** Left and Right Writer's Palm Prints

A major problem with taking a good set of **lower palm** print images on a livescan is that often the center or cupped part of the palm is not adequately printed. The operator must ensure that they apply enough gentle pressure on the center of the back of the hand to capture more of this detail. If pressure is not applied to this area then the image that is being captured will be missing a large portion of ridge detail that could be used for positive identification.

The **writer's palm** is helpful in forgery and fraud investigations since the side of the hand comes into contact with the item. When capturing this area on the livescan, start with the palm of the hand flat on the platen and then roll the hand up towards

the little finger side of the hand, about 45 degrees. You should be able to see ridge detail in the captured image on the livescan monitor. If you do not see ridge detail then you have rotated the hand too much and will need to re-capture the image.



*Poor Capture*



*Good Capture*

**Fig. 15-11** Poor and Good Capture Examples

### V. Wisconsin DOJ and FBI Search Requests

When a law enforcement agency has a **rush** case involving individuals of questionable identity, submission of a fingerprint record to the Wisconsin DOJ and the FBI is a quick way to see if the subject has an existing record within the AFIS or NGI system. While this may not positively identify someone, it will let you know if they have a record under the name that was given or a record under a different name by fingerprint comparison.

#### **Search of Wisconsin State Files**

Before submitting the search, agencies must contact the Madison Crime Laboratory's AFIS Section (608-266-2031) to let the staff know to expect a **rush** search request and to ensure that it is handled in a timely manner. Search requests are available during standard Wisconsin State Crime Laboratory working hours: M-F; 7:45a to 4:30p. The AFIS Identification Technicians will complete a name check with Criminal History and a fingerprint search through the AFIS. Search results

should be available the day the request was made, but may be delayed if the request was made at the end of the day, outside of business hours, if the submitted record is of poor quality, or if there is high system volume or system maintenance.

## Livescan/Cardscan Electronic Submission

When calling in a rush search request, please provide the following information to the AFIS Identification Technician to aid in the processing of your record: Agency name, phone number, point of contact, the subjects name, DOB, and sex/race, the date and time the record was submitted and the Transaction Control Number (TCN) of the record being sent to the AFIS. This number is issued by the livescan or cardscan device.

The image shows the Transaction Control Number (TCN) WI1030207001. Each part of the number is enclosed in a red rectangular box: 'WI' in the first box, '1' in the second, '1030207' in the third, and '001' in the fourth.

Fig. 15-12 Example TCN

**WI** (Agency Identifier); **1** (Device Number); **030207** (Creation Date); **001** (Sequential Number that recycles each day)

The TCN can be found by opening the record on the livescan/cardscan device after capture of the prints. This number is needed to locate the record within the AFIS workflow. Names are only used for Criminal History searches. All electronic submissions are sent to the FBI for search once the search of the state's files has been completed. These results will be returned to the contributing agency.

## Email Submission

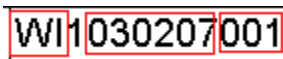
The AFIS Section can accept search requests submitted via email. Emails should be sent to [dojcrimelabafis@doj.state.wi.us](mailto:dojcrimelabafis@doj.state.wi.us). Please include a contact name and phone number for the staff to use if there are any issues and/or with results. The email should also contain the subject's full name, date of birth, and sex/race.

Fingerprint cards may be emailed for search purposes.

Fingerprint cards must be scanned at a minimum of 600 ppi, and should be submitted as a PDF or JPEG file format. Cards saved as TIFFs or BMPs will also be accepted. Please contact the AFIS Section at the above email if you need to use a different file type (due to file size limits on email) or for additional clarification.

### **Search of FBI's Files**

Requests for a query of name and fingerprints against the FBI database are handled by the Special Processing Center (SPC) in Clarksburg, West Virginia. They are available 24 hours a day, 7 days a week. You do not need to call ahead, but if you want to or have questions, the number is 304-625-5584. The turnaround time for results is 2 to 4 hours.

### **Email Requests**

Agencies may email fingerprint search requests to the SPC at SPC@LEO.GOV . Fingerprint cards must be scanned at 600 dpi/ppi and saved as either a PDF or JPEG. Along with the fingerprint card, please provide the following information: Agency name, address, ORI number, phone and fax number, point of contact, and the subject's descriptive data (name, DOB). If the agency does not have a LEO email account, the results will be faxed to the agency.

### **Fax Requests**

Requests for a query of name and fingerprints against the FBI database other than by electronic submissions are handled via fax through the SPC.

Fax submissions require a cover sheet including the following information: A statement that you are looking for an existing record on the subject and/or fingerprints, agency name, phone and fax numbers, point of contact, and the subject's descriptive data (name, DOB). Cover sheets are limited to one subject per sheet. Search requests for additional subjects should be sent in separate transactions.

You will need to provide one photocopy of the ten print card at 100% and one photocopy of the card at 129% on super-fine resolution if possible. This can be accomplished by rotating the fingerprint card on the photocopier to capture the fingerprint impressions only. All fingerprint images (rolled and slaps) will fit on an 8 ½ X 11 sheet of paper for faxing purposes. The subject's name and DOB must be written on the enlarged copy. Fax the one-to-one copy of the ten print card(s), along with the copy at 129%, and the cover sheet to the FBI Special Processing Center at 304-625-5587.

**NOTE: Some photographs in this chapter are used courtesy of MorphoTrak**

# Notes

## Burglary

**B**urglary is one of the offenses most commonly encountered by law enforcement officers. The initial investigation of a burglary scene is extremely important, for the objective is not only to determine what may be missing, but also to locate and recover physical evidence which associates the burglar with the crime scene. The following outline may be used by the investigating officer as a procedural guide when processing a burglary scene.

**Caution: Observe laws relating to the collection of evidence.**

### Evidentiary Considerations

#### I. Security and Protection at the Scene

- A. Allow authorized personnel only.
- B. Rope off or barricade area under investigation.
- C. Protect outside areas from elements with a new tarpaulin or plastic sheet.
- D. Maintain security until the scene is completely processed.

#### II. What to Look for

- A. In surrounding area:
  1. Footwear impressions (determine origin)
  2. Tire marks (determine origin)
  3. Drag marks
  4. Abandoned loot, tools, clothing, etc.
- B. At scene:
  1. Point and method of entry
  2. Object of burglary
  3. Point and method of exit
  4. Obvious objects of value “passed up”
  5. Fingerprints, glove imprints

- C. At point of entry:
  - 1. Hairs, fibers, other materials
  - 2. Chips of paint, wood, glass, and tools
  - 3. Blood
  - 4. Tool marks (photo)
  - 5. Tools
  - 6. Other items of evidence
- D. Inside burglarized premises:
  - 1. Finger, foot, footwear, and palm prints
  - 2. Burglarized objects
  - 3. Tools and source of tools (property of victim or perpetrator)
  - 4. Tool marks (photograph)
  - 5. Broken or fractured pieces of tools (may be recovered in floor sweepings)
- E. Suspect:
  - 1. Trace materials may be present on the clothing of a suspect. Therefore, all outer clothing should be submitted to the Trace Evidence Unit according to procedures outlined in [Chapter 22, Clothing and Fabrics](#).
  - 2. The vehicle involved should be thoroughly searched for the presence of physical evidence. Vacuum seats, floors, dash separately.

## III. Procedure at Scene

- A. Photograph and diagram the crime scene.
- B. Recover, mark and preserve physical evidence found according to directions set forth in section pertaining to evidence of that type.

## IV. Materials Required by Laboratory

- A. Photographs and diagrams or sketches of crime scene.
- B. Physical evidence that has been photographed, recovered, marked and preserved in the proper manner.



## Safe Burglary

In some rare cases, a safe may be drilled with a core drill to gain entrance. In these sophisticated types of burglary, the Laboratory should be contacted for assistance.

A diagram describing the accepted nomenclature of parts usually encountered in a safe burglary investigation has been included in an effort to show the correct names of safe parts. Knowledge and use of this terminology will aid the investigator and the Forensic Scientist in communicating effectively regarding safe burglaries.

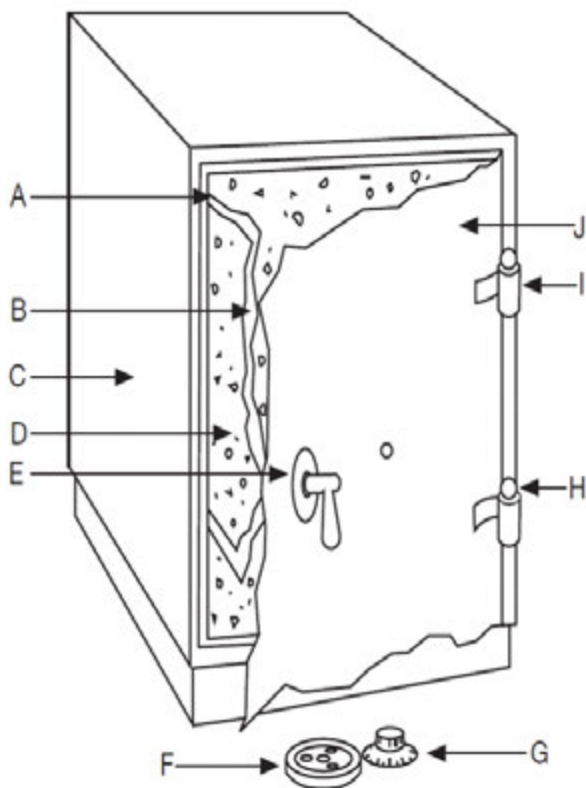

**Fig. 16-1** Safe Nomenclature

A Locking Bolt

B Carrying Bar

C Cladding (outer metal shell)

D Firewall Material

E Door Handle

F Dial Ring

G Dial

H Hinge Acorn

I Hinge

J Front Plate

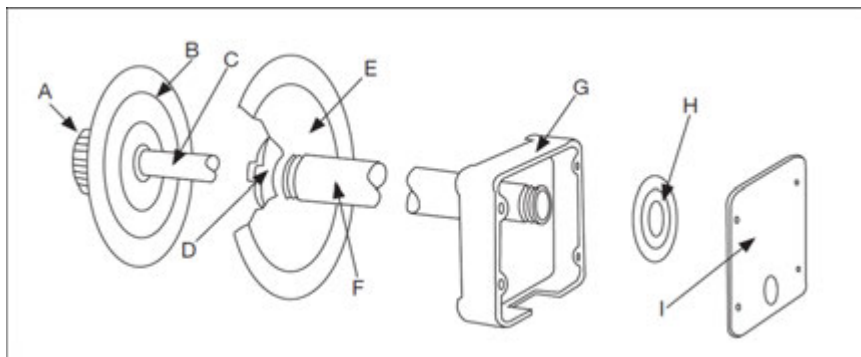

**Fig. 16-2** Combination lock nomenclature

A Dial Knob	D Tube Nut	G Lock Case
B Dial	E Dial Ring	H Wheel
C Spindle	F Spindle Tube	I Cover

Although explosives are not employed very often in safe burglaries, the possibility of their use should not be overlooked. If there is reason to suspect explosives were used, it is recommended the scene be evacuated and secured. Then, for guidance in handling the situation, contact one of the following:

- A local bomb squad
- The Federal Bureau of Alcohol, Tobacco and Firearms (ATF) - in Wisconsin, (414) 727-6170

If explosives are expected:

**Do not** attempt to neutralize or destroy remaining explosives.

**Do not** turn on any electrical switches.

**Do not** walk or step in a liquid or suspected explosive material.

**Do not** move any object.

**Do not** smoke or use matches in area.

**Do not** pick up any detonators or explosives.

**Do not** breathe any vapors which may be present.

Nitroglycerine may cause a very severe headache.

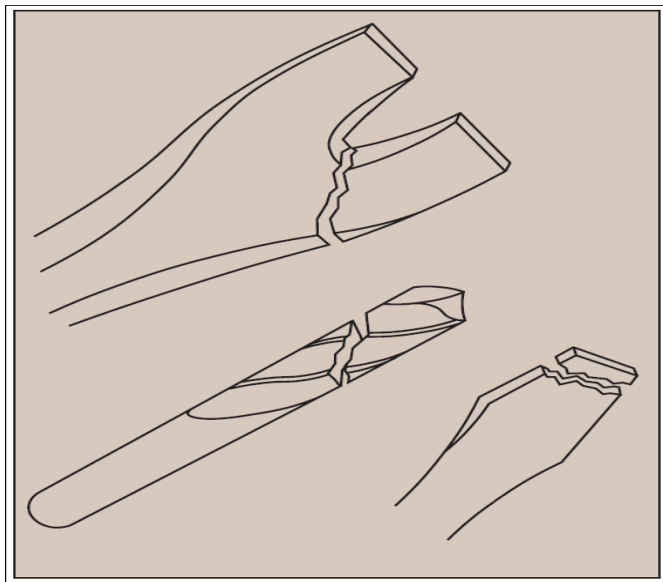

**Fig. 16-3** Fracture Matches of broken tools.

After the scene has been processed for finger-, foot-, and palm prints, it should be carefully swept to recover all debris. The debris pile should be thoroughly searched for the presence of broken tool parts and other physical evidence. Broken tool parts may be fracture matched with a suspect tool. This is a conclusive type of identification and is not uncommon in burglary investigations. The recovery and search for debris is frequently overlooked, however, resulting in the loss of valuable evidence.

# Notes

# Building Materials

*In investigations which involve breaking and entering, building materials such as paint, glass, wood, plaster, metal, etc., may adhere to the perpetrator's clothing or tools. These fragments may later be identified as originating from the scene. Building materials from different sources -which appear by visual examination to be similar - may be differentiated by their physical and chemical properties.*

## Procedure

### A. Crime Scene:

1. At the point of entry, or at any point of damage, collect samples of each type of building material involved (Fig. 17-3). Do not cut through tool marks. If one type of material has been damaged in several places, obtain known samples from each site since the composition may vary.
2. Any tool or instrument impressions found on building materials should be properly preserved and submitted to the Laboratory. Recover known sample of building materials from point of entry (see Fig. 17-3). Foreign paint in the impression may be linked to paint on a suspect tool. Use caution to preserve foreign matter.
3. When glass has been broken, collect all glass found at the scene. If more than one window has been broken, glass from each pane should be packaged and submitted **separately**. This also applies to thermo- or double pane windows and laminated windows.

If the direction of force used to break a window is in question, collect all glass from the window frame and from the ground inside and out. If the glass is removed

from the frame, be sure to mark one surface to indicate whether it was “inside” or “outside” when in the frame. Package each sample separately or submit the window frame with the glass in place (see [Chapter 18 - Glass](#)).

4. Care should be taken in choosing a container to avoid loss or contamination of the evidence. **Do not use plastic Petri dishes or mailing envelopes.**
5. Container should be marked with the following information, sealed, then submitted to the Laboratory:
  - a. Description of contents
  - b. Exact source of contents
  - c. Date and time recovered
  - d. Case and item number
  - e. Name of officer recovering the material
6. Recover all tools remaining at the scene for possible fingerprints and/or DNA.

### B. Suspects:

1. Collect all clothing worn by the suspect at the time of crime, including shoes (see [Chapter 22 - Clothing and Fabrics](#)).
2. Examine head and all bare skin areas (hands, arms, legs, feet) for fresh cuts that might contain building materials, especially glass. Building materials trapped in hair can be recovered by combing over a clean piece of paper or cloth sheet. Collect all trace evidence and combings.
3. Collect all suspect tools.
4. Examine interior and trunk of suspect’s car for debris and traces of building materials.

5. If the suspect claims a source for materials found, obtain a known sample from the claimed source.
6. Package all of these samples separately as described above. Avoid cross-contaminating samples taken from the suspect with those taken from the scene.



**Fig. 17-1** Trace transfer of materials may be found adhering to pry bars.

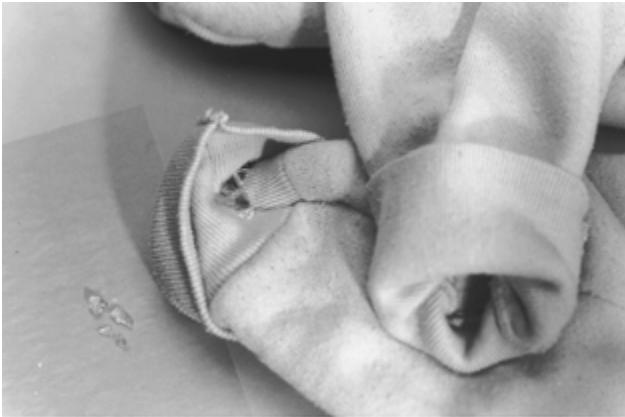

**Fig. 17-2** Glass chips recovered from the suspect's clothes which are consistent with glass broken at the scene.

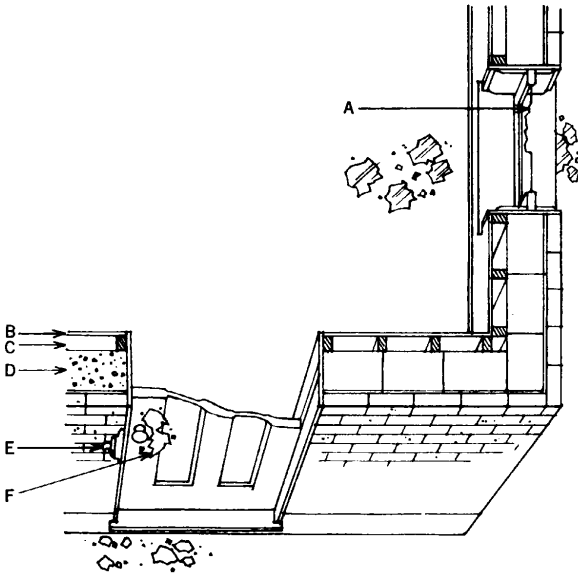

**Fig. 17-3** This cross section of a burglary scene shows the various materials that should be recovered. In this case, an unsuccessful attempt was made to gain entry by forcing the door frame and adjoining wall. Entry was finally gained through the window. Known samples should be taken of all damaged materials:

- |  |                             |
|--|-----------------------------|
| A Known glass remaining in the window frame  | C Building insulation       |
| B Wallboard, plaster, wallpaper, paint, etc. | D Building block and mortar |
|  | E Brick and mortar          |
|  | F Wood from door            |

**Note:** Recover and package separately building materials from ground outside point of entry (i.e., at the door) as well as glass fragments found inside and outside the building.



# Glass

One of the more important types of physical evidence which is frequently overlooked by the investigator is glass. Its evidentiary value lies in the fact that there are thousands of different formulae used in the manufacturing of glass.

## I. General

Recovered glass samples may be separated into several groups: two of the main groups are window/windshield glass and headlight glass.

EXAMPLE 1: The glass recovered from a broken window at a burglary scene and glass recovered from the clothing and shoes removed from a person suspected of committing the burglary.

EXAMPLE 2: The glass remaining in a broken vehicle headlight assembly and the glass recovered at the scene of a hit-and-run investigation.

Considering these examples, it should be noted that the glass which is recovered from a known source, such as a broken window or a broken headlight, is considered **known** glass. The glass recovered from the clothing and shoes or the hit-and-run scene is considered **questioned** glass.

Comparison of irregularly shaped fractured edges of pieces of glass may reveal a puzzle-like match which indicates that two sources of glass were at one time a part of the same object. It should be noted that tempered float glass, the kind used in vehicles, business windows and doors, and residential shower doors **cannot** be fracture matched as they expand upon breaking.

If a fracture match is not possible, comparison of known glass with questioned glass may reveal similarities in their physical, optical, or chemical properties. This type of examination may result in a class identification. That is, there is more than one headlight or window that will have the same properties as the known headlight or window. Therefore, specific identification can not result from measurements of physical, optical, or chemical properties.

It is also possible to determine the direction of force used to break glass by examining stress marks present on the broken edges. In order to do this, it is necessary to reconstruct as much of the original pane as possible. Therefore, **all** glass from the scene must be recovered to reconstruct the item so the point of impact can be determined and detailed examination of the individual fragments can be conducted.

**Caution: Observe laws relating to the collection of evidence.**

## II. Procedure

### A. Fracture matches

1. Fracture matching is the most positive form of identification and therefore it is of utmost that all glass fragments be recovered, since it is impossible to know in advance which recovered pieces will mate with one another.
2. Collect **all** glass fragments from **all** sources (i.e., scene, vehicles, clothing, etc.) and package glass from each source **separately** in order to associate the glass from any one source with the scene.

### B. Chemical analysis

3. Collected for comparison with glass samples recovered from remote locations or from the clothing

to show commonality of chemical make-up. (Does *not* individualize a sample to a single source.)

4. Recover a sample of glass still in the frame. Glass from the window frame is the only source that can be used as a known for chemical analysis.

### C. Determination of the direction of force

1. It is preferable to remove the window frame with the remaining glass still in place and to submit it to the Laboratory. If this is impossible and the glass must be removed from the frame, be sure to mark each piece to indicate the “inside” surface or the “outside” surface before removed from the frame. Collect all glass from the window frame.
2. Glass found in different areas should be recovered and packaged separately. Example: Glass found on the floor inside should be packaged separately from glass found outside. It cannot be overemphasized that glass recovered from different areas should be packaged separately.

### D. Packaging

1. Package glass pieces in rigid containers such as a plastic specimen bottle. Protect the broken or fractured edges of the pieces of glass from any additional damage or breakage.
2. The value of the procedure for packaging glass from different sources separately will be nullified if the packaging material tears or breaks, allowing transfer of small pieces or fragments of glass between packages. **Do not** package glass in paper, mailing envelopes, cellophane, plastic bags or glass vials.

# Notes

# Tool Marks

**T**ool mark identification techniques may be applied to many types of evidence in investigations (e.g., knife marks on bone, fractured knife blades, vise marks on homemade explosive devices, crimp marks on detonators, cut marks on wire, fractured radio antennas, etc.) including burglaries.

## I. General

For the purposes of this chapter, a tool is any instrument or object capable of making a mark on another object.

A close examination of a tool mark may reveal the type of tool, contour of the cutting or prying edge, prying edge width or the presence of trace material

## II. Types of Tool Marks

Generally, tool marks encountered at a crime scene may be in the form of impressed markings, striated “drag” or “shear” marks created by tool movement during contact, or a combination of both (see Figures 19-1 and 19-2). For example, a drive punch will generally leave an impression tool mark, whereas a screwdriver or pry bar will frequently leave a striated mark as well as an impression of the tip of the tool.

## III. Location of Tool Marks

Tool marks may be found at entry and exit points in buildings or vehicles and upon objects which have been attacked with a tool or other object.

## IV. Recovery of Tool Marks

- A. Always submit the object exhibiting tool mark(s) to the Laboratory.
- B. If it is not practical to submit the object, remove the section of the material containing the tool mark and submit the section to the Laboratory.

- C. *Only as a last resort*, make a cast of the tool mark.
- D. Mark, protect and individually package item(s) containing tool mark(s) and submit to the Laboratory.

### V. Casting of Tool Marks

Silicone based casting materials have been found to be satisfactory for casting tool marks although not all materials perform adequately. Brown “Mikrosil” possesses the best combination of casting and examination qualities. Directions for their use are contained in each kit.

Do not use Plasticine<sup>®</sup>, plaster of Paris, patch plaster and similar materials which have a tendency to shrink.

### VI. Tools

**Caution: Observe laws relating to the collection of evidence.**

Recover and inventory all suspect tools observing the following precautions and submit them to the Laboratory for examination and comparison with tool marks.

- A. Never place a suspect tool in contact with a questioned tool mark or cast.
- B. Inscribe identification marks on tools for later identification. Exercise extreme care in handling and marking tool(s) if it is to be checked for fingerprints, DNA and/or trace evidence.
- C. Package each tool individually to prevent cross-contamination.

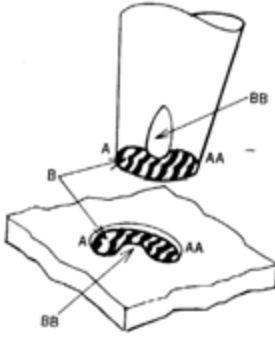

**Fig 19-1** Impressed Tool Mark

A-AA portion of the tool mark reveals the class characteristics (size and shape) of the tool.

B-BB reveals individual characteristics of this particular tool. Marks on surface B are grinding or manufacturer's marks; BB is a nick in the edge of the tool.

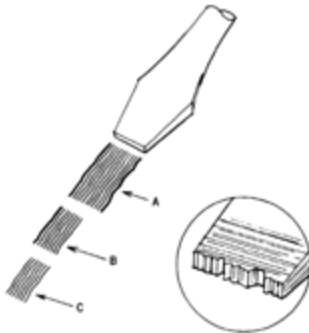
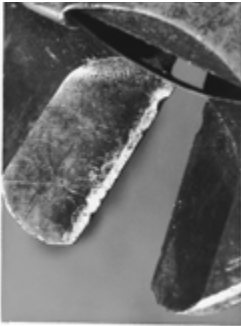

**Fig 19-2** Striated tool mark

- Area A shows the entire prying edge width of the tool. The intervening lines, or striations, are the unique marks created by the tool's individual physical characteristics.
- Area B, a partial tool mark, shows one side of the prying edge of the screwdriver and unique marking detail.
- Area C, a partial tool mark, does not show either side of the prying edge, but does show individual markings.
- Inset circle shows an enlarged view of the edge of the tool's prying edge, showing individual physical characteristics acquired during manufacture, use, misuse, regrinding, or intentional alteration.



**Fig. 19-3** Double-bladed tools such as bolt cutters are often used to cut padlock shackles. When recovered in the possession of a suspect, they may connect the offender with the crime.



**Fig. 19-4:** Damage to the cutting edges of the blades creates individual markings on the materials cut by the bolt cutters.

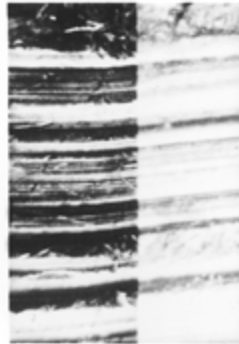
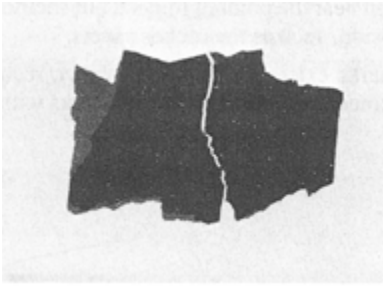

**Fig. 19-5:** This comparison microphotograph illustrates matching patterns of unique detail that result in an identification in a tool mark comparison.



# Paints

**P**aint chips and fragments of other protective coatings such as varnishes, sealers, lacquers, enamels, and plastics are frequently recovered at scenes of burglaries, hit and run vehicles and scenes, forced entries, etc. A determination of common origin is possible in cases where irregularly shaped adjoining edges of paint chips can be physically joined to form a fracture match (see Figure 20-1). However, the value of a single-layered paint chip or paint smear should not be overlooked.



**Fig. 20-1** Fracture match of paint chips. Two fragments of paint showing a common fracture match. One fragment was found at the scene of a crime. The other was recovered from the suspect vehicle.

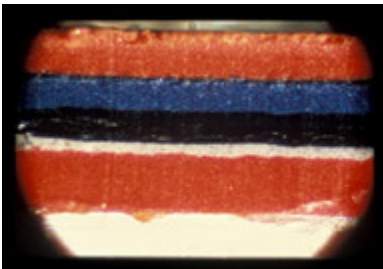

**Fig 20-2** Cross section of multi-layer paint chip. Each layer represents a separate painting operation. (Magnification approximately X350).

## Procedure

The following procedures are recommended for recovery of paint samples.

**Caution: Observe laws relating to the collection of evidence.**

- A. Recover, package, and seal all paint samples separately.
- B. Recover known paint samples from areas immediately adjacent to the damaged area. The hoods, trunks, and fenders of vehicles may not be painted at the same location or with the same paint used on the body. Therefore, it is of utmost importance that a known paint sample be taken from the **exact part of the vehicle upon which the damage occurred**. In hit-and-run investigations, the known paint samples should be taken near the point of impact, but should not be taken from areas of corrosion, such as the rocker panels.
- C. When tool marks exist on a damaged object, recover paint samples from areas immediately adjacent to tool marks without mutilating the tool mark. If feasible, the item may be submitted to the laboratory for paint collection.



**Fig 20-3** Recovery of Paint Sample: Tape a clean sheet of paper (**do not** use envelopes) to the object in the manner shown, forming a pocket. Mark the paper for identification. Scrape the questioned paint into the pocket formed by the paper. It is important to use a new, disposable scalpel blade or razor blade for each sample to avoid contamination. Some razor blades are coated with oil to prevent rusting. Therefore, **all** razor blades should be thoroughly cleaned with a clean cloth or tissue just before they are used.

- C. When areas of paint are missing from sheet metal parts of vehicles or doors and windows of residences and businesses, consideration should be given to bringing the entire part to the Laboratory for possible fracture match analysis.

- D. Avoid use of any container which would permit loss or contamination of contents, especially envelopes and plastic Petri dishes, since the manufacturer's seal is not leak proof.
- E. Use a new, clean scalpel blade or razor blade for each sample recovered. A plastic specimen bottle or 35mm film canister can be used for paint sample. Fold paper packets containing paint samples and place in an envelope, pill box or other suitable container. Seal and mark appropriately. **Safety tip** – when using a single-edged razor blade, a commercially available razor blade holder should be used to avoid injury if the blade slips or breaks during sampling.

A clean, sharpened putty knife or slot-head screwdriver can be used at times to start collecting harder paint samples. A separate pre-cleaned putty knife or screwdriver should be used for each known and questioned paint.

- F. **DO NOT USE tape lifts or other gummed tapes to recover paint samples** because it interferes with the chemical analysis.



**Fig 20-4** Packaging Paint Sample

Carefully remove the paper from the object and fold each edge toward the center so that the packet is completely closed.

# Notes

# Metals

*It is possible to compare metals on the basis of their elemental composition and surface morphology. Even minute particles can be examined. Questioned metal fragments which have been broken from their original source may often be fracture matched to that source.*

**Caution:** Observe laws relating to the collection of evidence.

## Procedure

Recover all metal fragments found at the scene. These should be sealed in vials, bottles, paper bags or other suitable containers. Package and label.

Recover and submit all metal objects involved or encountered in an investigation. Although metal fragments may not be found at the scene, they may be detected later when the clothing is examined, since they may adhere to the surface or lodge in pockets and cuffs or to shoes. Therefore, it is important to have for comparison the object from which the fragments may have originated.

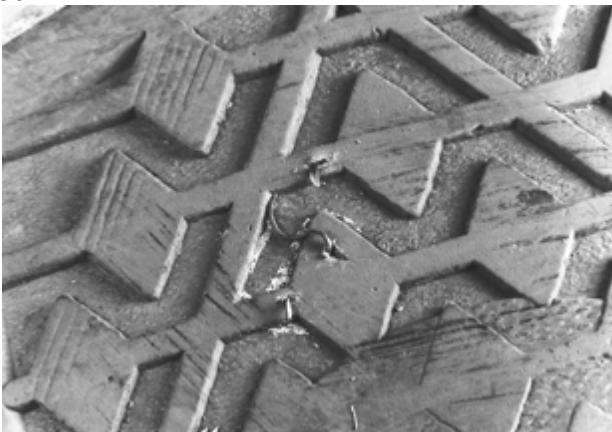

**Fig. 21-1** Trace metal and glass fragments can often be recovered from the soles of shoes if the suspect walks through such evidence during commission of the offense.

# Notes

# Clothing and Fabrics

**C**lothing fibers or small pieces of fabric found at burglary scenes, on suspect hit-and-run vehicles, weapons, or other objects can often be compared or even matched with a suspect's or victim's clothing. Small particles of paint, plastic, metal, wood, glass, soil, or other materials frequently adhere to clothing (pockets, trousers, cuffs, etc.) and may be related to the scene.

*The Laboratory has special equipment to recover trace evidence from clothing. Clothing recovered for examination should be handled with care to avoid damage to critical areas. It is important to collect clothing before it is cleaned or otherwise altered. Trace materials are usually removed or lost in the cleaning process.*

**Caution:** Observe laws relating to the collection of evidence.

## I. General Procedure

- A. Recover clothing to be examined. Clothing should be carefully removed from the person or body. A piece of clean paper should be spread under the person to collect any trace materials dislodged during the removal. The paper and any debris thereon should be packaged with the item. Care should be taken to minimize damage to garments. **Do not** cut through stains, bullet holes, or knife penetrations. Collect and package each item separately. It is extremely important to keep items separated to avoid contamination during recovery, storage, and transmittal to the Laboratory.
- B. A tag marked with all pertinent information should be attached to each item. Lead wire seals or locking plastic cable ties may be used to attach the tag to the clothing.

If a lead seal is used, it can be crimped and inscribed with the officer's initials. Plastic cable ties can be marked with an indelible marker.

- C. Exterior clothing or fabric that may be an impression source should be carefully handled to protect from alteration. Submit the entire item(s) with impression evidence if possible. Oblique lighting is an excellent means of locating fabric impressions.

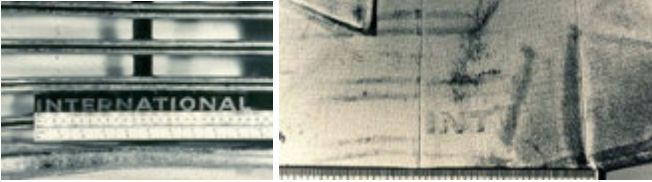

Fig. 22-1 Impact transfer of vehicle (left) to clothing (right)

- D. Clothing or other items that are damp or wet with blood, urine, water, etc., should be air dried in a draft-free place prior to packaging. **Do not package damp clothing or other damp items in plastic bags.** A piece of clean paper should be spread under drying items to catch any debris which might be dislodged. The paper and any debris thereon should be packaged with the item. Label, seal and submit to the Laboratory.
- E. Package each dry item in a clean paper bag, label and seal.
- F. Plastic bags are **not** suitable at any time for packaging shoes and other leather objects. A new, clean paper bag should be used for each leather object.

## II. Packaging Items

- A. Mark the paper bag with identifying data (description, source, date, time of recovery, case number, initials of persons involved in recovery, and other pertinent



information).

- B. Seal the bag using one of the methods discussed in [Chapter 1 - Evidence Integrity](#).



**Fig. 22-2** Fabric impression on a license plate from a hit-and-run investigation.

# Notes

# Hairs and Fibers

*In crimes where personal contact has occurred, especially if there was physical force, hair and fibers are frequently found as evidence. A cross transfer of hair and/or fibers between a victim and an assailant can provide supportive evidence of an association. In addition, hair recovered from the scene may serve to associate an individual with the scene. Fibers recovered from the clothing of the victim, suspect and crime scene can be compared to known textile materials to determine possible sources of origin.*

*If a hair is determined to be of human origin and is deemed probative to a case, DNA analyses may be performed on the root (if present) of the hair. Another form of DNA analysis (mitochondrial analysis) may be performed on the hair shaft if the root is absent.*

**NOTE:** Mitochondrial DNA analysis is not available at the Wisconsin State Crime Laboratory. See [Chapter 6 - DNA Evidence and Standards](#) for more details.

## I. Collection of Hair and Fiber Standards

It is necessary to obtain standard hair and fiber samples from all possible sources (suspect, victim and scene) for comparison with questioned hairs and fibers.

DNA analysis on hair roots has replaced microscopic hair comparisons. Pubic and head hair standards are still necessary for determining which foreign, questioned hairs may be subjected to DNA analysis. Due to the ease of head hair transfer and potential limited probative value, DNA analysis on hairs is limited.

**A. Head hair standards.** Obtain at least fifty (50) head hairs by cutting them at the skin surface. These hairs should be col-

lected from various areas of the head such as the crown, sides, front and back to assure that all shades of color and texture have been adequately sampled. The quantity of hairs obtained from a deceased individual should be doubled and the hairs should be **pulled**. Place the hairs in a clean, properly labeled envelope and seal.

**B. Pubic hair standards.** *Obtain at least twenty (20) pubic hairs by cutting them at the skin surface.* The hairs should be collected from various areas within the pubic region. If this is a deceased individual, double the number of hairs to be collected and pull them. Place the hairs in a clean, properly labeled envelope and seal.

**C. Known fibers** should be obtained from all possible sources (clothing, drapes, rugs, etc.).

1. Submit the suspected source in total if possible. Place the source in a clean, properly labeled paper bag and seal. (See [Chapter 22 - Clothing and Fabrics](#).)
2. If it is not feasible to submit the source in total, a sufficient quantity should be taken to ensure that each color and kind of fiber involved has been sampled. Place the fibers in a clean, properly labeled envelope or glass jar and seal. (See [Chapter 22 - Clothing and Fabrics](#)). Fibers should not be packaged in plastic bags due to static electricity.

## II. Collection of Questioned Hair and Fibers

**A. Pubic hair combings.** (Usually collected in sexual assault cases and from homicide victims).

Place a piece of paper under the pubic region of the individual and comb through the entire pubic area to dislodge any foreign hairs or other material that may be present. Place the used comb onto the paper and fold the paper around the comb being careful not to lose any of the dislodged evidence. Place the wrapped comb in a clean, properly labeled envelope and seal.

**B. Other Recovered Questioned Hairs and Fibers.** Separately package the hairs and fibers collected from different persons and different locations.

1. When the amount of evidence is very small, extreme care should be exercised to avoid contaminating or inadvertently losing the material.



Fig. 23-1 Fibers found on vehicle part

2. The hair or fiber should be placed on a piece of clean white paper and the paper should be tightly folded around the hair or fiber. Place the paper packet in a clean, properly labeled envelope and seal.



**Fig. 23-2** Fibers collected and placed on clean white paper adhered by clear adhesive tape.

# Notes

# Woods and Sawdust

**W**oods Product Lab. Wood slivers and chips from doors, siding, or broken window frames, frequently adhere to suspect's clothing and may be related to their source. Large items of wood such as boards, logs, trees, or blocking may also be identified by appropriate Laboratory examination and comparison.

Sawdust is generally composed of many types of species, samples from both the suspect and the scene may provide valuable information. Sawdust on shoes, in trouser cuffs, and in pockets of suspects who have recently left a crime scene such as a butcher shop, lumber yard, construction site, or similar location may prove useful during investigation.

**Caution:** Observe laws relating to the collection of evidence.

## Procedure

Damaged wood found at burglary sites should be submitted for comparison with recovered wood fragments from suspect's clothing and/or tools used to commit the crime. All clothing (including shoes) worn by the suspect at the time of the crime should be submitted to the Laboratory. See [Chapter 22 - Clothing and Fabrics](#) for packaging procedures. If there are wood chips or sawdust at the scene, take several samples from different areas, package separately, mark and seal. Samples can be placed in small glass bottles or vials. Avoid use of envelopes since wood fragments may be damaged during transit if not protected in a rigid container. Package, seal and label the container. See [Chapter 18 - Glass](#).

**The Wisconsin State Crime Laboratory does not identify wood type. Physical matches are possible at the Laboratory** (see Chapter 25 Fracture and Tear Matches).

Study and research on woods are conducted by the USDA Forest Service's Forest Products Laboratory reportedly working to promote healthy forests through the intelligent use of wood. Located in Madison, Wisconsin with Twitter account Forest Products Lab@fsWoodLab, the website is <https://www.fpl.fs.fed.us/>.



**Fig. 24-1** Fracture match of a wood fragment to a piece of wood used as a bludgeon.



**Fig. 24-2** Fracture Match of an axe.



## Fracture and Tear Matches

**I**f the irregularly shaped fractured or torn edges of two or more pieces of any material can be joined together to form a continuous section, then it can be concluded that the pieces at one time shared a common origin. This comparison is the most positive conclusion that can be drawn in the area of trace evidence. The Forensic Scientist has eliminated all other similar materials as the source of the pieces.

Investigators often carefully check a scene for fingerprints or DNA, knowing their value to conclusively link a person to the scene – while overlooking a torn piece of paper, a broken piece of metal or glass, or other broken item. Any of those items can, if another piece is found in the possession of a suspect, form just as conclusive a link with the scene.

A fracture match results when two pieces of rigid material (plastic, wood, glass, metal, etc.) from separate locations are reconstructed to form a continuous section of that material (see Table 25-1). A cut or tear match results when two pieces of pliable material (such as, plastic bags, paper, foil, fabric, etc.) from separate locations are reconstructed to form a continuous section of that material. Perforated paper products (checks, notebook paper, LSD blotter paper, etc.) can often be linked back to their source via tear matches (see Table 25-2).

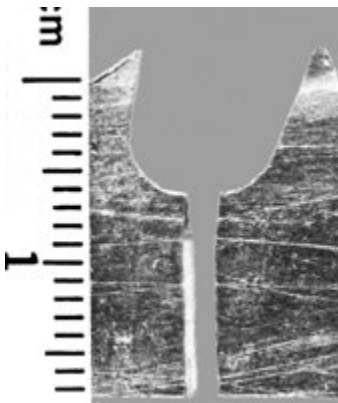

**Fig. 25-1** Fracture match of a broken saw blade.

**Table 25-1**  
**Examples of Potential Sources for Fracture Matches**

Motor Vehicles	Bicycles	Burglary	Miscellaneous
Paint chips	Tubular metal	Paint*	Knives
Headlights	Reflectors	Wood*	Feathers
Grill	Lights	Tool parts	Stone
Exterior mirrors	Tires	Glass	Bones:
Antenna	Inner tubes	Safe wall	Animal
Windshields	Spokes	Metal:	Human
Wipers	Fenders	Doors	Fingernails
Parking lights	Baskets	Trim	
Tail lights		Machinery	
Trim pieces			

\* fractured material may be found adhering to a tool

**Table 25-2**  
**Examples of Potential Sources for Tear/Perforation Matches**

Matches	Cardboard
Documents	Money
Paper bags	LSD blotter paper
Checks	Drug folds
Stamps	Cloth/fabric
Sheet plastic	Plastic bags
Duct tape	Other Tape

### **Importance of Thorough Collection and Proper Preservation**

It is of the utmost importance that **all** pieces of the broken item(s) at the scene be collected and preserved for later comparison with similar evidence collected from the suspect, victim, vehicle, home or other scenes; it is impossible to know in advance which pieces will be matched to each other. This requires a careful and thorough search of the scene.

Package items from each location **separately**. In order to confidently establish a link between an item left at the scene and another item recovered elsewhere, each item's origin must be documented. If items are, or could be co-mingled during collection, storage or transport, their evidentiary value is lost. See [Chapter 1 - Evidence Integrity](#) for further information on packaging and sealing.

For information on specific types of fracture matches and procedures associated with their collection, see the following chapters: [Chapter 16 - Burglary](#), [Chapter 17 - Building Materials](#), [Chapter 18 - Glass](#), [Chapter 19 - Tool Marks](#), [Chapter 20 - Paints](#), [Chapter 21 - Metals](#), [Chapter 24 - Woods and Sawdust](#), [Chapter 26 - Vehicles](#) and [Chapter 35 - Questioned Documents](#).

# Notes

# Vehicles

**T**he Laboratory accepts cases involving automobile accidents which have resulted in injury or death and where criminal negligence is suspected. Vehicles involved in accidents of this type should be immediately impounded. Where skid damage on the vehicle's tires may indicate related important conditions prior to or at the time of impact, the vehicle should be conveyed on a trailer to a storage facility. The Laboratory also may accept vehicles involved with the commission of a sexual assault or conveyance of a body. Always contact your area laboratory prior to submitting the vehicle.

*It is very important that proper photographs of the scene, skid marks, damage to vehicles, impact damage, etc. are obtained. The Laboratory does not perform accident reconstruction, or condition of mechanical or electrical systems determinations. These types of analyses must be sought from another source.*

## **Criminal Damage to Motor Vehicles and Engines**

The perpetrators of criminal damage to motor vehicles may add a foreign substance, such as emery dust or sand, to the vehicle engine or transmission. Where internal damage of this type is suspected, a sample, consisting of one pint of oil from the top and bottom of the oil pan of the damaged engine, should be submitted. Any foreign residue found on top of the engine in the carburetor, or near the oil spout should also be submitted. It is important that as much sediment as possible be obtained from the oil pan or gear box.

In cases involving addition of sugar or other materials to gasoline, submit **at least** one pint of gasoline from the tank. Because sugar has a low solubility in gasoline, it is imperative that the intact fuel filter as well as a sample of the sediment or condensation (water) in the bottom of the gasoline tank be

submitted.

Samples from fuel pump bowls should be avoided because they contain sediments which interfere with tests. However, the sediment bowl can be removed so that a sample of gasoline may be pumped directly into the sample container.

Containers with rubber or waxed paper seals should not be used, since they dissolve in petroleum products and give erroneous test results. Pistons, bearings, gears and scrapings from the combustion chamber or rings may also be submitted. Samples of the radiator coolant also may be examined for evidence of foreign substances when indicated.

**Caution:** It is unlawful to send flammable liquids via mail.

### Stolen Vehicles

The Laboratory may be able to identify stolen vehicles which have been repainted or stripped or which have had the serial or manufacturing numbers altered or replaced.

If a vehicle is suspected of having been repainted, it is possible to analyze and photograph the paint layers as confirmatory evidence and to establish the original factory color. See [Chapter 20 - Paints](#) for the recovery technique.

When an automobile has been stripped and the suspect parts are found, the Laboratory may be able to physically match these to the vehicle.

Stamped serial numbers may be removed by grinding or altered by other methods. Frequently, they may be restored. When alteration of the serial number is suspected, the object or part bearing the serial number should be submitted.

For general technical information, contact the Laboratory or the National Insurance Crime Bureau (NICB) at [www.NICB.org](http://www.NICB.org). In

some cases, confidential, hidden vehicle identification numbers may be present to assist in determining authentic vehicle identification.

## Hit-and-Run Investigations

In attempting accident reconstruction, the investigator should be mindful that showing a relationship between materials or items recovered from different locations is most important. Materials or items recovered from different sources or at a later date that can be related to each other constitutes very important evidence. Three primary sources should be considered: the accident scene, vehicles and victims.

### I. Accident Scene

#### A. Initial Procedures:

1. Request ambulance personnel at scene to preserve blankets and clothing which may contain trace evidence such as broken glass, paint chips, metal parts, plastic, etc.
2. In vehicular accidents, an officer should be assigned to the hospital to assist in the recovery of clothing and body fluids.

#### B. Protect scene from:

1. Additional accident damage
2. Bystanders
3. Theft from vehicles

#### C. Establish a written record:

1. Date
2. Time
3. Location
4. Description of incident
5. Weather conditions
6. Temperature
7. Road conditions

8. Victim's location upon your arrival, his/her condition and tentative identification
  9. If a description of the hit-and-run vehicle can be obtained, immediately have dispatcher alert other officers in the surrounding area. The vehicle's description may be obtained from eye witnesses or materials recovered at the scene.
- D. Attempt to locate the fleeing driver and/or vehicle.
- E. Photograph the scene (see [Chapter 2 - Forensic Photography](#)).
- F. Diagram the scene (see [Chapter 4 - Crime Scene Sketch](#)).
- G. Recognition of potentially valuable materials:
1. Broken glass (headlights, mirrors, and windshield) or plastic from scene or from victim's clothing may be fracture matched with remaining glass or plastic from suspect vehicle.
  2. Broken or fractured pieces of metal (trim, antenna, or sheet metal pieces) may also be fracture matched with section remaining on vehicle.
  3. Paint chips from scene or vehicle may be fracture matched with suspect vehicle (see Figure 26-1). Paint layer relationship may be valuable evidence (see Figs. 20-1 and 20-2 in [Chapter 20 - Paints](#)).



**Fig. 26-1** Paint chip fracture match to a suspect vehicle believed to be involved in a fatal hit-and-run accident.



4. Dirt deposits recovered from road surface may be indicative of approximate point of impact.
5. Physical impressions left on objects at the scene may indicate the make of vehicle causing the impact. They should be properly recorded and collected for possible comparison purposes at a later date.
6. Skid marks and three-dimensional and surface impressions sometimes can be used to determine direction and speed. There are limitations to the usefulness of skid marks, debris, and gouge marks in establishing the exact point of impact. They will, however, indicate the approximate location of the collision. Broken parts found at the accident scene may bounce and roll; therefore, reliable information as to exact point of impact may not be able to be determined.

## II. Victim

### Living:

1. Obtain complete identifying data to include full name, date and place of birth, permanent address, temporary address (if nonresident), telephone number where he/she can be reached when discharged from hospital.
2. Recover blankets used in conveying victim to hospital. Tag blankets and place each in a separate paper bag. Air dry if wet or blood stained. Avoid handling blankets any more than necessary to preclude loss of trace material.
3. Recover clothing worn by victim at time of accident. Note any cutting or tearing of clothing by nurse, attending physician or other person rendering aid. Tag each item of clothing and place in a separate clean paper bag. Air dry if wet or blood stained. Avoid unnecessary handling of clothing to prevent loss of trace material.
4. Collect body fluids:

#### **Blood:**

- Collect at least 5 milliliters of blood in a lavender-topped (EDTA) blood collection tube, then print patient's name on the label. Using a small syringe,

insert needle through the rubber stopper of the tube (EDTA) and withdraw approximately 1 milliliter of blood. Using a DNA Stain Collection Card, fill all four (4) of the printed circles on the card with blood. Allow bloodstains to thoroughly air dry, then write patient's name on the DNA Stain Collection Card. Package the Stain Collection card in a clean, properly labeled paper envelope and seal. Package the blood tube in a styrofoam shipping container, label properly and seal. Store in refrigerator.

- Collect 20 milliliters (two tubes) of blood in gray-topped (sodium fluoride) blood collection tubes for toxicological analysis. Print the patient's name on the labels. Package the blood tubes in a styrofoam shipping container, label properly and seal (see [Chapter 30 - Toxicology](#)).

### **Urine:**

Collect all available urine in a plastic or glass jar used by hospitals for sample collection. Preservatives are not necessary. Seal and label for identification. Store in refrigerator (see [Chapter 30 - Toxicology](#)).

5. Ensure that chain of custody is maintained. Everyone who has the item in his/her custody, even for a short time, must be documented. See [Chapter 1 - Evidence Integrity](#) for further discussion of this topic.

### **A. Deceased:**

1. Photograph the body (see [Chapter 2 - Forensic Photography](#)).
2. Note position of body. If postmortem lividity has developed, determine if it is consistent with position of body when found.
3. Use caution when removing body to avoid loss of possible trace material. The body should be placed in a new, unused white sheet before being placed in a clean, sealed body bag.
4. Check under victim for trace evidence.
5. See [Chapter 27 - Autopsy](#) for additional information including procedures for recovery of clothing and foreign

materials.

6. See [Chapter 30 - Toxicology](#).

### III. Vehicle

- A. Avoid touching any part of the vehicle which may bear fingerprints (e.g., steering wheel, mirrors, door handles, brake handle, gear shift handle, seat belt fasteners, hood, windshield, roof, etc.). To shift gears for towing, grasp the stick rather than the end knob where suspect may have left prints.
- B. Protect the vehicle from contamination by covering with *new* wrapping paper or plastic sheeting.
- C. Transport on a flatbed truck or trailer or tow (do not drive) vehicle to nearest garage. Proper examination of the understructure requires the use of a hoist.
  1. The vehicle should not be towed any extended distance. Trace evidence such as blood or hair may be lost or destroyed.
  2. The vehicle should be towed or hauled from the *undamaged* end to avoid additional damage and to avoid destruction or addition of evidence during towing See Figure 26-2).

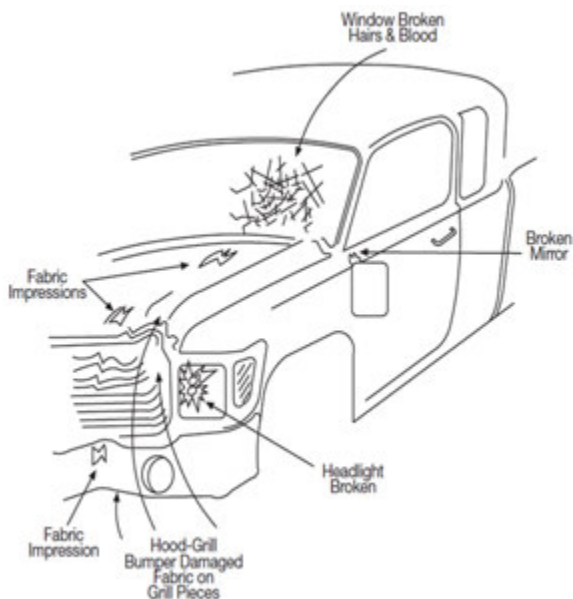

Fig. 26-2 Vehicle towed from undamaged end to an area laboratory.

3. The vehicle should be placed under lock and key. Police security should be maintained to ensure the custodial chain of the vehicle.
- D. Photograph the vehicle (see [Chapter 2 - Forensic Photography](#)).
- E. Record an accurate description of the vehicle.
- F. Recover known and questioned paint samples. Paint samples should be taken from both the damaged areas and adjacent undamaged areas. The latter serve as controls or knowns during Laboratory comparisons. Paint samples should also be taken from the victim's vehicle. Fenders, hoods and doors with areas of missing paint should be removed for fracture match analysis with recovered paint samples. Where bicycles, baby strollers, snowmobiles, power lawn mowers or other small vehicles are struck, the entire object should be sent to the Laboratory. See [Chapter 20 - Paints](#) for procedure in recovering paint samples.
- G. In the event that glass has been broken, recover and submit all known and questioned samples.
- H. Metal, glass and plastic pieces showing fractured edges should be removed, because they may be fracture matched to pieces from the scene.
- I. A systematic examination should be made of the vehicle exterior including the undercarriage.
- J. If the suspect vehicle is located some time after the accident (after having secured the properly-executed search warrant), immediately record the temperature of the radiator and out-of-doors temperature. Record serial numbers, vehicle identification numbers (VIN), license numbers, condition of brakes, tires (evidence of skidding),

mileage reading, service record, approximate amount of fuel in tank and condition of all lights.

- K. Examine vehicle for presence of blood, hair and fibers. If investigation indicates vehicle passed over victim, the understructure should be examined. Known samples of grease should be recovered and recovery location noted.
- L. Fabric weave impressions on metal surfaces or paint and in grease should not be overlooked. When possible, the bumpers, hoods or the entire vehicle should be conveyed to the Laboratory for proper photographic documentation of such impressions. To be of use for comparison, all photos must be life-size (1:1) and include a scale.
- M. Sketch vehicle and note on sketch any damage and the locations of materials recovered. This will be useful during your recollection at any court proceedings (see Fig. 26-1).
- N. Properly mark vehicle for identification.



**Fig. 26-3** Perspective sketch of a vehicle suspected in a hit-and-run accident. Sketch illustrates vehicle damage and locations of trace material and other evidence.

# Notes

# Autopsy

**A**n autopsy is required in all violent or unattended deaths to determine the cause and possible manner of death. An unattended death is one for which there is no preexisting illness, medical condition, or reasonable explanation.

Where there is reason to believe foul play is involved in a human death, and when a request is made by an authorized agency, Laboratory personnel may assist a forensic pathologist during the autopsy.

## **I. Procedure for the Officer**

- A. Obtain authorization for the autopsy from the coroner or medical examiner. This authorization must be in writing and delivered to the pathologist prior to performance of the autopsy.
- B. A complete set of x-rays should be taken of the entire body. If metal fragments are detected, a side view should be taken to help locate the exact position of the fragments.
- C. Record the following and any other information considered pertinent:
  - 1. Name and date of birth of deceased (if known).
  - 2. Any emergency medical treatment performed on victim.
  - 3. Time, date, and location of autopsy.
  - 4. Names and titles of persons in attendance.
- D. Inform the pathologist of all pertinent information relative to the case.
- E. If the pathologist is unaware of the specimens required by the Laboratory for their analyses or the methods preferred by the Laboratory to recover and preserve specimens, provide

him/her with Section II of this chapter.

- F. Photograph the body as outlined in [Chapter 2 - Forensic Photography](#) – IV. Autopsy Photographic Procedure.
- G. Recover the (new) sheet used to convey the victim from the scene to the hospital or morgue. IMPORTANT: Mark the sheet “**INNER HEAD**” to denote which side of the sheet covered the body and where the head was located. Air dry if wet or blood-stained and collect trace evidence on paper placed under the sheet while drying. Place all in a separate clean paper bag. Avoid unnecessary handling of the sheet to prevent loss of trace evidence. Properly mark for identification.
- H. Bindings used to restrain victim, if any, should be recovered by cutting an area where no knots, cuts, tears, or stains are present. Do not cut through knots or stains. Mark the cut ends to distinguish from existing ends of bindings or twine.
- I. Bite marks. The first step in the processing of bite marks is to photographically document the impression. The photography is critical and the specific method is described in [Chapter 2 - Forensic Photography](#) - VI. Pattern Impression Photography - D. Bite Marks. Because of the specific requirements to produce workable evidence, it is recommended to request technical assistance from the Laboratory. IT IS EXTREMELY IMPORTANT TO SWAB THE BITE MARK AREA FOR DNA EVIDENCE COLLECTION. This can be accomplished by using the Department of Justice BIOLOGICAL SPECIMENS collection kit available through Document Sales and Distribution <https://docsales.wi.gov/> or by following the procedure described below.

After the bite mark is thoroughly documented photographically, the impression should be swabbed with a moist cotton applicator to collect assailant’s saliva. Thoroughly air dry the swab and place in a clean paper envelope. Properly label and seal the envelope.



When three dimensional characteristics are apparent, the evidence can be further documented with an impression material. It can be difficult to obtain the detail necessary. Technical assistance is available by calling the Laboratory for a referral to a Board Certified expert. There is a nominal fee for this forensic specialty.

- J. Recover clothing of victim after it has been examined by the pathologist. Note any cutting or tearing of clothing by anyone who may have rendered first aid, such as the attending physician, or by the pathologist. Place each item of clothing in a separate clean paper bag. Air dry if wet or bloodstained. Avoid unnecessary handling of clothing to prevent loss of trace evidence. Properly mark for identification.
- K. After examination by the pathologist, all bruises and wounds should be photographed. Scaled and unscaled views should be taken prior to and after washing of affected areas. Scaling should be accomplished following procedures outlined in [Chapter 2 - Forensic Photography](#) - V. Scaling Photographs and VI. Pattern Impression Photography.
- L. In cases where the victim may have, or is suspected of having had physical contact with the assailant, recover standard specimens of body and head hairs and package them separately, by location, in clean containers. See [Chapter 23 - Hairs and Fibers](#).
- M. Fingerprint and palm print the victim (see [Chapter 14 - Major Case Prints](#)). Also consider footprints. Investigation at the crime scene may reveal palm prints or footprints. Personal identifications may be confirmed by footprints. If the victim is too young to have been fingerprinted, hospital records may contain newborn footprints.
- N. Package, seal and label all items recovered making sure the pathologist describes the contents and places his mark of

identification on each item or container. It is important that the officer in attendance be equipped with adequate containers and sealing apparatus to package clothing, body fluids, organs, hair samples, fingernail scrapings, etc.

- O. Request that the pathologist forward a copy of the autopsy report to the coroner/medical examiner.

## II. Procedure for the Pathologist

- A. A complete series of full body x-rays should be taken of the victim.
- B. Collect the clothing of the victim by carefully removing them in a normal manner. Should this not be possible, they can be removed by cutting. Great care must be taken not to cut through or near any cuts, tears, holes, or trace evidence or areas that might have evidential significance.
- C. Recover wound areas:
  - 1. Photograph wounds as outlined in [Chapter 2 – Forensic Photography](#) - IV. Autopsy Photographic Procedure, V. Scaling Photographs and VI. Pattern Impression Photography.
  - 2. The body may be sketched and wound areas diagrammed on anatomical outlines similar to those shown in Fig. 27-1. All drawings should be initialed and dated with the case number on each page.

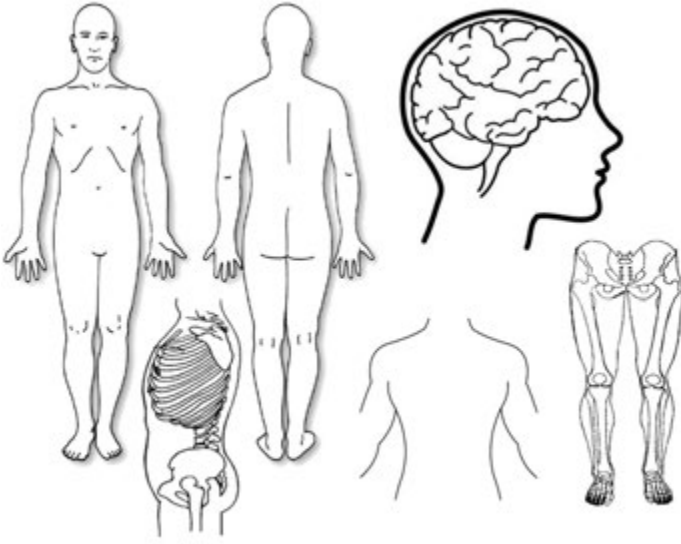

**Fig. 27-1** Anatomical Outlines

3. Tissue sections surrounding gunshot wounds may be recovered as shown in Fig. 27-2.
  - a. The tissue section should contain most or all of the powder staining and/or residues. For proper orientation, it should be removed in the form of a tear drop. The “point” of the section of tissue should be towards the top of the head. If the bullet penetrated bone, obtain a section of the bone penetrated and underlying bullet track surrounding the bullet hole. The recovered sections of tissue and/or bone should be placed in a wide mouth screw cap jar with a ten percent solution of formaldehyde, sealed, and labeled.
  - b. Do not submit these sections to the Laboratory. The Laboratory does not analyze tissue specimens for the presence of gun shot residue. They should be examined by a Forensic Pathologist or retained for future use.

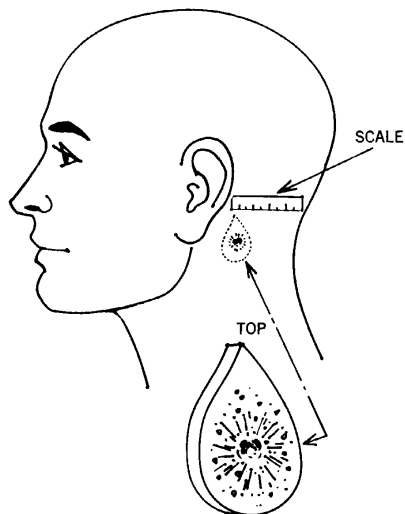

**Fig. 27-2** Recovery of wound area

- D. Collect all evidence, including fragments of bullets or other objects which have pierced or adhered to the skin. The pathologist should place a mark of identification on the sealed container in which the recovered evidence is placed. An alternative method is to mark the individual item and the sealed container. See [Chapter 10 - Firearms and Ammunition](#), for marking and packaging procedure. In cases involving gunshot deaths, or gunshot injuries suspected to have been self-inflicted, it is important to obtain measurements of arm length (fingertip to shoulder, arm extended). It is also important to photograph all bloodstains on all exposed areas of flesh, such as hands, wrists and arms.
- E. Additional specimens should routinely be collected at autopsy (if applicable) and submitted to the Laboratory:
- See [Chapter 7 - Sexual Offenses](#) - collect the appropriate specimens for the situation.
  - See [Chapter 23 - Hairs and Fibers](#) - collect the appropriate specimens for the situation.

- See [Chapter 30 - Toxicology](#) - collect the appropriate specimens for the situation. Many of the samples required for toxicological analysis can be collected using an autopsy kit you may prepare using items as specified in Figure 27-3. Specimens for sexual assault analysis should also be collected; especially in any homicide involving a female victim-even if sexual assault is not immediately suspected. A Sexual Assault Evidence Collection Kit is available for this purpose at no fee the Document Sales <https://docsales.wi.gov/>. Additional information on sexual offenses can be found in [Chapter 7](#).



**Fig. 27-3** Example of the retired Crime Lab autopsy kit containing:

- Clean jars, (1) 8 oz, (2) 4 oz., (2) 2 oz. (*urine may be collected in sterile urine cups*)
- (2) Gray-topped blood collection (bc) tubes (Sodium Fluoride)
- (1) Purple-topped bc tube (EDTA)
- (1) DNA stain card with envelope (*DNA buccal swab collection kit may be used*)
- Form documenting collected items that are clearly identified
- Transmittal Form

# Notes

# Identification of Unknown Deceased

*Identification of an unknown deceased victim is of utmost importance and must be vigorously pursued until every investigative lead has been exhausted. Much information can be obtained by a detailed examination of a body, clothing on the body and personal effects found in clothing pockets or at the scene. Caution should be used, however, in attempting positive identifications from clothing and personal effects alone since it is possible an unknown body may be clothed in the garments and personal effects of another.*

## Identification Procedure

The condition of a body when recovered is a limiting factor in identification; however, a thorough examination may reveal information which initially would appear to be impossible to obtain.

The positive identification of a deceased victim should not be construed to be the duty of the Forensic Scientist or investigating officer, but rather a joint effort of all persons concerned. Few of the following listed “investigative leads” are, in themselves, a basis for positive identification. But several together, supported by a thorough investigation, may be sufficient basis upon which to establish a possible or probable identification.

The following checklist will provide investigative leads which, if properly pursued, may lead to a positive identification.

### A. Visual external Examination of Body

1. Fingerprints, palm prints and footprints
2. Complete physical description to include:

- a. Sex
- b. Age
- c. Weight
- d. Height
- e. Build
- f. Color of eyes (Glass eye)
- g. Race
- h. Skin:
  - (1) Complexion
  - (2) Tattoos
  - (3) Piercings
  - (3) Warts, moles, birthmarks
  - (4) Skin disease
  - (5) Scars—injury or surgical
  - (6) Needle punctures (narcotic addicts or diabetics)
  - (7) Ring mark on finger (ring missing)
- i. Hair:
  - (1) Color
  - (2) Length and how combed
  - (3) Straight, wavy and amount
  - (4) Natural, wig or toupee
  - (5) Beard, mustache, type
- j. Teeth:
  - (1) Natural or false
  - (2) Appearance (shape, stains)
  - (3) Dental work (fillings, missing teeth, bridgework)
- k. Fingernails:
  - (1) Long, short, chewed or broken
  - (2) Manicured, fingernail polish
  - (3) Discolored due to occupation
  - (4) Artificial nails
- l. Amputations and deformities

### **B. Examination of Clothing**

1. Description and size of all garments
2. Manufacturer, store, tailor labels
3. Laundry markings (some can be seen by use of ultra-violet light)



4. Laundry tags left on clothing
5. Monograms
6. Repair or presence of tears and holes
7. Belt buckles
8. Buttons (missing, broken, special type)
9. Visible stains
10. Trace material which may indicate occupation

### C. Identification Photographs

Include frontal and side views of the victim's head and any scars, tattoos, jewelry or other visible identifying characteristics or objects



**Fig. 28-1** Photograph of a tattoo on a homicide victim

### D. Review of missing person reports

Viewing of body by family or acquaintances of missing person(s)

### E. Internal Examination of the Body

1. X-ray examination and/or body scanning. A body which is unidentifiable by external means should be subjected to a complete x-ray examination and or body scan in order

to determine the presence of:

- a. Foreign bodies such as pieces of shrapnel, fired bullets, etc.
  - b. Body Implants such as prosthetics (metal skull plate, bone screws and nails, breast implants, etc.), medical monitoring devices, etc.
  - c. Mended bone fractures
  - d. Other abnormalities which may aid in identification
2. Body organs missing as a result of surgery
  3. Improper location of body organs
  4. Evidence of a present or prior illness:
    - a. Heart disease
    - b. Ulcers
    - c. Arteriosclerosis
    - d. Pathological changes due to age, occupation or geographical residence
    - e. Stomach contents

### **F. Personal Effects**

1. Driver's license
2. Credit cards
3. Social Security card
4. Identification card
5. Identification tag
6. Photographs:
  - a. Self
  - b. Family
  - c. Acquaintances
  - d. Locations
  - e. Names and other writing on photographs
7. Letter or other notes
8. Company checks or check stubs
9. Paid and due invoices
10. Rings:
  - a. Wedding rings
  - b. Class rings
  - c. Organization rings
  - d. Initials

11. Cigarette case and lighter
12. Car and house keys
13. Key rings: initials or other personalization, registration number for lost key return service
14. Monogrammed wallet
15. Watch:
  - a. Engravings
  - b. Jeweler repair marks
16. Corrective lenses:
  - a. Contact lenses
  - b. Prescription
17. Hearing aids

### **G. Additional Techniques**

1. X-ray examination of teeth (see [Chapter 29 - Dental Identification of Human Remains](#)).
2. X-ray of skull superimposed over negative or print of photograph of victim's head.
3. DNA profiles from the body may be matched to DNA collected from personal effects of missing persons or searched against national data bases.
4. Blood type and factor: the type may be rare and the victim a donor whose name may be on file at hospital or blood bank. ABO and Rh typing is no longer performed at the Crime Laboratory. If required, a private or clinical laboratory should be contacted.
5. Facial reconstruction.

# Notes

# Dental Identification of Human Remains

*If you are unable to establish the identification of an individual by visual means, fingerprints or other identifying data, then a dental examination should be done. Due to the medicolegal ramifications, this should be carried out by a qualified forensic odontologist. Human remains will usually be burned, mutilated, decomposed or skeletonized. There have been numerous times when dental examinations have been done on victims who are visually identifiable.*

If a body is recovered and cannot be identified, the dental records should be submitted to the National Crime Information Center (NCIC) after a very thorough postmortem dental examination. It is also appropriate to place the dental records of missing persons in the NCIC. If a person is missing for a period of time (30-90 days), the dental records can be obtained and entered into the NCIC computer. If this information is not filled out correctly, it can prevent an identification from taking place. There is a large amount of information for the family dentist to read, and it may be difficult to understand the NCIC form if he/she only sees one of these forms in his/her career. If you would like an NCIC form completed for a missing person, the Laboratory can direct you to one of their consultants who will complete it at no charge.

## Forensic Postmortem Dental Examination

### I. Examination of the Oral Tissues

- A. In certain circumstances the examination can begin at the site where the body was found or a return trip may be warranted. A forensic odontologist may be able to help locate and identify dental remains that are decomposed,

charred or traumatically mutilated. Some of the fragments may appear to be burned pieces of wood or other debris.

- B. A single tooth, jaw fragment or even a portion of a tooth may be vital to the identification.
- C. As easily as teeth break down throughout life, they will outlast all other body tissues after death.
- D. Postmortem head and neck x-rays (or full body x-rays) may locate dislodged teeth or fragments. X-ray examination of dirt or charred debris may also reveal fragmentary evidence.
- E. Conditions of the bodies that may be examined.
  - 1. Normal condition or visually identifiable.
    - a. A dental examination should be conducted if:
      - (1) There are no reports of a missing person or clues to the identity
      - (2) There are no personal effects are found
      - (3) There are no fingerprints are on file
    - b. Dental examination should proceed with **no** disfigurement to the face (no resection or removal of the jaws). Body may be viewed by relatives
    - c. Dental examination would consist of photographs of the teeth, a dental chart, a full mouth series of standard dental x-rays with a portable dental x-ray machine and impressions of the teeth.
  - 2. Completely decomposed or skeletonized.
    - a. Easiest to work on.
    - b. Some of the teeth will dislodge from the jaw since the periodontal ligaments (tissue that attached the teeth to the bone) have been destroyed in the decomposition process. All loose teeth should be recovered and replaced in their sockets.
  - 3. Partially decomposed.
    - a. Difficult to examine due to the odor and presence of insects (e.g., maggots, flies, beetles, etc.).
    - b. Jaws need to be resected.
  - 4. Burned.

- a. Access to the teeth is very difficult as the tissues are very rigid.
  - b. Jaws need to be resected.
  - c. Caution is advised in resecting heavily burned or calcined jaws since they are extremely fragile. Fixation with clear acrylic spray is recommended.
5. Mutilated.
- a. Teeth and jaws may be fragmented and distorted.
  - b. Recovery of all the teeth may be a problem.
  - c. Dental evidence may be imbedded in other areas of the body or strewn about the area.
- F. Resection of the maxilla (upper jaw) and the mandible (lower jaw).
1. Usually in cases of advanced decomposition, severe mutilation and bodies that are charred or burned beyond recognition, the jaws will need to be resected or removed.
  2. Resection of the jaws should be accomplished if there is no open casket or viewing of the body.
  3. The forensic odontologist can accomplish a more complete and comprehensive examination and obtain better quality x-rays and photographs by resection of the jaws.
  4. If the jaws need to be retained for a period of time, they may be preserved in 10% formalin.

## II. Preparation of Post-mortem Records

- A. Photographs.
1. Full face.
  2. Close-up of the anterior or front teeth.
  3. Right and left lateral views of the teeth in occlusion or their proper bite.
  4. Views of the occlusal or chewing surfaces of the teeth in the upper jaw and in the lower jaw.
  5. Close-up photography of any additional features which may be important.

B. Radiographs or x-rays.

1. Essential to any forensic dental examination.
2. Exposure time is reduced by  $\frac{1}{3}$  for resected jaws and  $\frac{1}{2}$  for skeletonized jaws.
3. X-ray examination is mandatory for estimation of age of the victim.

C. Notes and charts.

1. A dental chart should be prepared indicating all pertinent information.
2. This information should include, but is not limited to:
  - a. Which teeth are present and which are missing.
  - b. Which teeth are restored or filled, what the restoration or filling material is, and which surfaces of the teeth are involved.
  - c. Indicate if root canals have been performed.
  - d. Describe any prosthetic and/or orthodontic appliances.
  - e. Describe the location and size of the decayed surfaces (cavities) of the teeth or if there are any chipped or fractured teeth.
  - f. Describe any malpositions or rotations of teeth.
  - g. Describe unusual anatomy or shapes of teeth.
  - h. Describe the occlusion (the manner in which the teeth bite together).
  - i. Describe any oral pathology or other anatomic features which may be of potential importance.

D. Study models or casts of the teeth.

1. Impressions can be taken of the victim's teeth and then casts are made by using dental stone.
2. It is usually not necessary or practical to take impressions of the victim's teeth. However, there have been many occasions where casts have proven to be very valuable.
3. The consulting forensic odontologist will decide if this procedure is warranted.



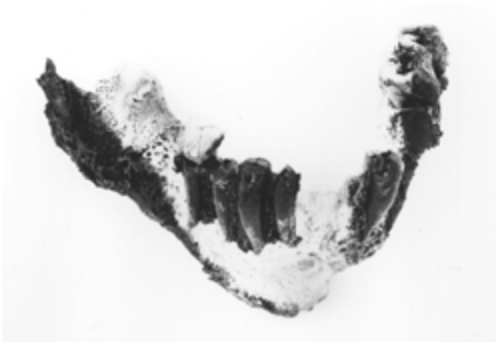

**Fig. 29-1** Example of charred dental remains. The mandible (lower jaw) has the crowns of the teeth fractured off.



**Fig. 29-2** Examples of charred fragmentary dental remains (teeth and bone fragments).



**Fig 29-3** Examples of charred, fragmentary dental remains. Many of the fragments may look like charred pieces of wood or debris. The fragment that is second from the left in the top row is a charred piece of wood.

## III. Securing of Ante Mortem Records

- A. Types of ante mortem records.
  - 1. X-rays.
    - a. X-rays are the most important ante mortem records.
    - b. Recover and submit all x-rays, including those x-rays taken 10-20 years ago. These x-rays may reveal additional information and may compare more favorably with the postmortem x-rays of the remains.
    - c. Obtain the original x-rays if at all possible. The dentist should duplicate the x-rays and retain the duplicates for his/her records. The original film should be a better quality x-ray than the duplicate.
    - d. Obtain the most recent ante mortem records. Most individuals have probably been treated by more than one dentist throughout their lifetime.
    - e. If conventional dental x-rays are unavailable, recover medical or chiropractic x-rays that may show the teeth.
    - f. Electronic transmission of scanned images of dental x-rays saved as bit map files can be accomplished when expediency is required. An initial rule-in or rule-out comparison can be made of the electronic image on screen. The original films can be sent later if necessary.
  - 2. Dental charts.
    - a. Obtain the original dental chart if possible. If the dentist sends a copy, make sure the copy is legible.
    - b. Dental charts can be very valuable, but the forensic odontologist must be aware that there may be errors incorporated into the chart by the dentist, the dental assistant or the hygienist making the entry. For this reason, x-rays are a much better means of making a comparison.
  - 3. Study models or casts of the teeth. If the dentist has retained models, they can be very valuable. If the individual has seen an orthodontist, there may be a very good possibility of obtaining study models.

4. Photographs.
    - a. Many dentists obtain photographs of their patient's teeth as a means of documenting dental condition.
    - b. Family snapshots, graduation, wedding or military pictures may reveal a "smiling photograph." Teeth may be visible and disclose a missing, discolored, broken or chipped tooth.
  5. If partial dentures or full dentures are involved, request that all additional sets of dentures be recovered. A bite splint, mouth guard or orthodontic retainer should also be recovered.
- B. Recover all ante mortem records available (including charts, x-rays, photographs and study models). X-rays that may be requested are bite-wing x-rays, periapical x-rays, a full mouth series of x-rays (consists of periapical and bite-wing x-rays), a panoramic x-ray or a lateral skull x-ray.
- C. How to locate the treating dentist to obtain the ante mortem dental records.
1. Inquire of family, friends and co-workers what dental clinic or dentist treated the individual.
  2. Inquire if the individual was treated or consulted a dental specialist (oral surgeon, orthodontist, etc.).
  3. Inquire if the individual had a dental insurance plan, a union dental plan, medical assistance or welfare benefits. This could lead to a dentist's name.
  4. Examine military and prison records.
  5. Examine medical records to see if the physician has a record of the name of the dentist.
  6. In a small community, it may be necessary to contact all the dentists and inquire if they have treated this individual.

#### **IV. Comparison of the Ante Mortem and Postmortem Records and X-rays**

- A. The more areas of alterations or problems with the teeth,

the greater the potential for a positive identification. With a perfect set of teeth (no decay, no fillings or restorations and a good occlusion or bite), or if there are minimal post mortem or ante mortem remains for examination, an identification may be more difficult. It may still be accomplished; however, meticulous attention needs to be paid to all minute detail. Excellent ante mortem and postmortem x-rays are always preferable.

- B. A positive identification must bear no unexplainable inconsistencies. Any differences in the ante mortem and postmortem records must be thoroughly and adequately explained.
- C. There is no specific number of characteristics needed for a positive identification. Occasionally, a single tooth or jaw fragment may possess the degree of specificity necessary to establish a positive identification. The final decision as to the degree of credibility of the dental identification rests with the judgment and experience of the forensic odontologist.
- D. Occasionally, the postmortem records are only consistent with the ante mortem records, and a positive identification cannot be effected based on the dental information alone. However, a dental finding of “consistent” may be a significant contribution. It may be used in combination with other modes of identification (fingerprints, personal effects, anthropological or other medical findings, serology, etc.), and serve as corroborating evidence and increase the credibility of the final identification.

# Toxicology

**F**orensic toxicology testing is requested in many situations. These situations routinely involve testing for foreign substances (drugs and toxins) in biological specimens. Since there is no single test that can detect all drugs and toxins, a systematic approach is used in each laboratory to focus on the substances deemed appropriate for that particular case. The investigator is always encouraged to communicate all relevant information to the toxicology unit, such as any drugs an individual is suspected of taking. This aids in conducting an efficient analysis. If an investigator is unsure whether a suspected drug can be detected by the Crime Laboratory's Toxicology Unit, please contact your local Toxicology Unit to inquire.

**Caution:** Observe protocols relating to the collection of evidence. (See [Chapter 1 - Evidence Integrity](#) and [Appendix A - Bloodborne Pathogens](#).)

## I. Choice of Specimens

Blood and urine are the most commonly analyzed specimens in toxicology. More information regarding drug and alcohol levels can be found in these two specimens than in any others. Toxicology results from these specimens provide the strongest basis for the interpretation of effects and exposure.

**NOTE:** In living individuals the concentrations of drugs in these fluids are constantly changing depending upon the relationship between the time of dosing and the time of sample collection.

### Blood Samples

**Blood/serum/plasma samples are the specimen of choice for investigations dealing with the effects of a drug on an individual's functioning and behavior.** The primary example of this is a blood sample drawn for alcohol determination.

Doctors and toxicologists measure blood sample drug concentrations because they show the best correlation to the effects on an individual. Drug companies analyze these concentrations as part of their studies to determine “therapeutic” levels prior to releasing new drugs to market. These published living studies along with those cataloging blood levels associated with toxicity and death are of prime importance for a toxicologist’s interpretations of a drug’s effects.

Even when an accurate blood level of a drug is obtained, the interpretation of its effects – the impairment and toxicity of the drug on a particular individual should be done with caution. Factors that can complicate such interpretations are

- tolerance levels
- multiple drug interactions
- biological variation
- post-mortem redistribution

### Urine Samples

Drugs in urine samples can be detectable for days and concentrations can be many times higher than those in associated blood samples. **Because of this longer detection window and higher drug concentrations, urine samples are a better choice than blood samples for investigations seeking to answer the question of drug use or exposure.** Examples of investigations where urine samples should be collected are cases involving drug use (e.g., bail jumping cases) and drug facilitated sexual assaults.

Urine drug levels show poor correlation to drug effects and therefore published therapeutic/toxic ranges for urine are rare. Urine alcohol levels are a notable exception because, if properly collected, they can be related back to the associated blood alcohol levels.

### Detection Period

One of the most common questions asked of a toxicologist is “how long can drug X be detected in a person’s system?” This depends on a number of factors including but not limited to:

- the size of the dose
- the size of the individual
- the natural biochemistry of that individual
- the analytical capabilities of the laboratory (detection limits)
- the specimen being analyzed

**Table 30-1****Estimated Detection Periods for Selected Drugs in Blood and Urine**

<b>DRUG/METABOLITE</b>	<b>BLOOD</b>	<b>URINE</b>
<b>Cocaine</b>	2-8 hours	0.5-1 day
<b>Cocaine Metabolite</b> (Benzoylcegonine)	20-36 hours	1-3 days
<b>Heroin Metabolite</b> (Morphine)	4-12 hours	2-4 days
<b>Marijuana</b> active chemical (THC)	2-6 hours (infrequent user) Longer for heavy users	≤ 1 day (if detectable@ all)
<b>Marijuana Metabolite</b> (11-nor-9-Carboxy-THC)	12-72 hours	2-7 days (casual use) 28 days (heavy use)
<b>Methamphetamine</b>	4-24 hours	2-4 days
<b>GHB</b>	≤ 6 hours	≤ 12 hours
<b>Rohypnol Metabolite</b> (7-AminoFlunitrazepam)	≤ 8 hours	2-3 days
<b>Ketamine</b>	12-24 hours	1-2 days

**NOTE:** These detection periods will vary depending on an individual's drug use pattern, the specific user and the analytical capabilities/settings of the laboratory.

As a general rule, most laboratories will not detect drugs in blood if the blood is collected more than 24 hours after the last ingestion/exposure. Of course, there are exceptions to this rule with some drugs/metabolites exceeding this limit and others becoming undetectable prior to this limit.

See Table 30-1 for comparison of **detection windows** for selected drugs/metabolites in blood verses urine. In general terms, drugs are detected in blood on the scale of hours while they are detected in urine on the scale of days.

## II. Specimen Collection from the Living

### Blood Samples

Blood samples from living individuals must be drawn by a licensed physician, nurse or medical technician. The directions given below are directed primarily toward these medical professionals, but law enforcement personnel can also benefit from this information.

For blood alcohol determinations, the skin at the collection site should be cleaned with techniques that avoid solutions containing alcohol. Modern analytical techniques can distinguish among the different alcohols but it is highly recommended to use antiseptic towelettes (e.g., Zephiran® or benzalkonium chloride) that do not contain any alcohols for this sterilization step.

Fifteen to twenty milliliters of blood should be collected in gray-topped tubes. These tubes contain sodium fluoride as a preservative and potassium oxalate as an anticoagulant. Lavender-topped EDTA tubes can be substituted if necessary. After collection, gently invert the tubes for a few minutes to mix the additives into the blood. Each collection tube should be labeled with the following:

- the name of the individual whose blood was drawn
- the date and time of the blood draw
- the initials of the person drawing the blood

The tubes and the proximal container should be sealed to prevent unauthorized opening. This can be accomplished with the use of evidence tape placed over the top of the closed tube and around the proximal container and initialing across



the boundary between the tape and the tube/container. Best practice is to seal **both** the individual tubes *and* the proximal container.

## Urine Samples

When urine samples are collected for forensic purposes, the donor may be motivated to submit a false (clean) sample. In this situation, the urination should be observed by authorized personnel. Common ways to falsify a urine sample include dilution with tap or toilet water or by substituting clean, purchased urine for one's own urine. This can even be done through the use of an anatomically correct apparatus.

Twenty or more milliliters of urine should be collected in plastic cups that are manufactured for this purpose (see your local hospital) or in a pristine glass screw-top jar. After the urine is collected, the lid should be tightened and the container sealed with evidence tape. The collector/witness should place their initials across the boundary between the evidence tape and the container. The container should be labeled with the following information:

- the subject's name
- the date/time of collection
- the collector/witness's initials

Sealed the primary container in a plastic bag to retain any liquid that might leak, if the urine sample is to be transported. The plastic bag can serve as a secondary evidence seal if done properly. This will allow any leaked urine to still be analyzed if necessary. The person sealing this plastic bag should initial the seal. Do not place any paperwork inside this plastic bag in the event of a leak.

## Other Toxicology Samples

For other types of toxicology samples, follow the directions above for urine samples.

## III. Specimen Collection from the Deceased

For deceased individuals, an autopsy is often warranted (see [Chapter 27 - Autopsy](#)) at which time samples for toxicology should be collected. The selection of toxicology samples in post-mortem cases can vary; however, some samples are of primary importance. A tiered approach is used here.

### Tier One: Primary Specimens

**Blood:** Collect at least 20 milliliters in gray-topped tubes. As with living persons, blood is the primary specimen for postmortem toxicology. Blood collected at autopsy is routinely from the heart. This cardiac blood is usually plentiful and readily available. The collection of an additional blood sample from a peripheral site is a valuable adjunct to the cardiac blood because of the phenomenon known as postmortem redistribution (see below). Samples to substitute for blood can include spleen, bile and liver (see below).

**Urine:** Collect 15 or more milliliters of urine in a clean glass jar or a urine cup. Urine is a valuable specimen for the same reasons as discussed for living people. Urine alcohol levels can also be useful in decomposition cases to interpret the neo-formation of ethanol. Samples to substitute for urine include bile, liver and kidney (see below).

**Peripheral Blood:** Collect 10 or more milliliters of blood from a peripheral location (a femoral or subclavian vein) in gray or lavender-topped tube(s). Drug levels in cardiac blood can elevate over time following death as the drugs move from drug rich organs (heart/liver/lung) into the surrounding blood. This phenomenon, known as **postmortem redistribution**, is less pronounced in peripheral blood. Samples to substitute for peripheral blood include vitreous humor and liver.

**Vitreous humor (eye fluid):** Collect 2-5 milliliters in a gray-

topped tube. Vitreous fluid is useful for the interpretation of blood alcohol in cases of decomposition or trauma and can be related back to the associated blood alcohol level. This fluid can also be used to some degree as a replacement for peripheral blood.

**Stomach contents:** Collect the entire contents or a **measured** portion in a clean glass jar. Stomach contents can be used to determine the amount of drug taken by an individual just prior to death. This analysis can be helpful in determining suicidal intention. For accurate analysis, the toxicologist must be informed if only a portion of the stomach contents is submitted (e.g., “1/2 of the total stomach contents submitted”).

Ante-mortem blood/serum/urine samples collected upon admission to the hospital: These samples are very important in cases where the individual survived for a significant period of time in a hospital prior to death and can be used in lieu of post-mortem specimens.

## Tier Two: Replacement/Additional Specimens

**Spleen samples:** A representative sample (approximately 10-20 grams) in a clean glass jar. The spleen is a blood rich organ which can be used in lieu of liquid blood.

**Bile samples:** 5-10 milliliters in a gray-topped tube. Bile samples contain high drug concentrations and can be used in lieu of urine samples to screen for toxic substances.

**Liver samples:** A representative sample (approximately 50 grams) in a clean glass jar. Liver samples can be useful in cases of postmortem redistribution (see peripheral blood above) and extreme decomposition.

## Tier Three: Specialty Samples

**Hair samples:** Collect a large sample (at least one-half inch diameter lock of 3-inch long head hair) for toxicology work. Hair samples show historic drug use but are not useful for acute poisoning cases. The Wisconsin State Crime Laboratory does not currently analyze hair samples for drugs.

**Lungs:** Lungs can be collected in an airtight container (clean paint can) if solvent inhalation is suspected immediately prior to death. The gaseous headspace above the organ can be sampled for analysis of volatiles.

### IV. Specimen Storage and Shipping

All toxicology specimens should be stored according to the following recommendations:

- short term (weeks/months) – refrigerated storage
- long term (months/years) – frozen storage

**NOTE:** For frozen storage of liquid samples, insure there is enough airspace (about 10% of the volume) in the container to allow for expansion of the liquid as it freezes.

If specimens are to be sent through the mail, follow the U. S. Postal Service regulations regarding shipment of biohazardous evidence. Biological samples sent through the mail must be packaged in the following manner:

- The sample must be **triple packaged** in a primary leak-proof receptacle, a secondary container and a rigid outer shipping container.
- The two innermost (primary and secondary) containers must each be sealed and marked with a biohazard sticker.
- The primary container must be wrapped in enough absorbent material to retain the sample should the container leak or break.

For the most current information regarding packaging, see U. S. Postal Service, Domestic Mail Manual at [www.USPS.gov](http://www.USPS.gov) or IATA Packing Instruction 650.

## V. Toxicology Testing

Toxicology testing can be as routine as a single blood alcohol test or as complex as the quantitation of numerous drugs in multiple samples. The level of testing required generally depends upon the type of case and the charges pending. For the Wisconsin State Crime Laboratory, a general outline of testing is listed below.

### Blood Alcohol

Felony operating while intoxicated cases (OWI), crimes of violence such as domestic abuse, reckless use of a weapon and endangering safety often involve only alcohol testing. For the majority of these cases, if the blood alcohol level is high enough to prove impairment/intoxication (e.g., at 0.08% and above), no further drug testing will be done unless other arrangements are made. Generally, alcohol has the predominant effect over other drugs that may be present and is well suited to support these charges.

Probation and parole violations where the initial charge is a felony will be accepted and testing will follow the dictates of these release programs.

### Drug Screening and Confirmation

Drug screening and confirmation are the next level of toxicology testing for blood and urine samples. Immunoassay screening for a routine panel of drugs is usually performed first. Any immunoassay positives are followed by gas chromatography/mass spectrometry (GC/MS) confirmation. The current immunoassay panel includes

- amphetamine
- methamphetamine
- cocaine/metabolite
- opiates (e.g., codeine, morphine, hydrocodone, hydro-morphone, oxycodone, heroin metabolite, 6-MAM),
- benzodiazepines (e.g., diazepam, alprazolam, clonaz-

- epam, lorazepam, flunitrazepam)
- phencyclidine (PCP)
- barbiturates
- cannabinoids (marijuana)

This level of testing is often used for felony suspects in controlled substance cases and homicide victims where the cause of death (e.g., shootings or stabbings) is known.

Samples can also be screened using a GC/MS general drug screen. This drug screen detects a broad spectrum of acidic, basic and neutral drugs including over 150 pharmaceutical compounds.



**Fig. 30-1** Manual Solid Phase Extraction and tubes used by the Forensic Toxicologist in preparation for drug confirmation(s).

## Additional Testing

Additional tests are available and are utilized as needed or requested. These include

- GHB (gamma-hydroxybutyrate) which is routine for drug facilitated sexual assault cases
- LSD
- salicylates (aspirin)
- acetaminophen

Please inquire about additional testing if necessary.

**Communication between the Crime Lab and the submitter is important to ensure the proper level of testing.**

## VI. Which Lab? Hygiene Lab or Crime Lab

The State of Wisconsin has two independent FORENSIC TOXICOLOGY laboratory systems. One is the Wisconsin State Crime Laboratory which is part of the Wisconsin Department of Justice and the other is the Wisconsin State Laboratory of Hygiene (WSLH) which is part of the University of Wisconsin System. For animal toxicology cases contact the Wisconsin Veterinary Diagnostics Laboratory (see contact information below).

The submitter should select the correct laboratory prior to mailing. **Valuable time is lost and the chain of custody is extended when specimens are sent to the wrong laboratory.** For this reason, if you are using a WSLH kit for a Crime Lab case do not use the mailing label supplied with the WSLH kit; instead use a mailing label for the Crime Laboratory serving your area (Madison covers the Wausau Lab service area for toxicology). It is also important to include a completed Transmittal of Evidence Form when WSLH kits are submitted to the Crime Lab.

Table 30-2 should help determine the toxicology laboratory to use.

By statute, the Crime Laboratories are only *required* to accept cases involving a felony or a potential felony. The Crime Laboratories will make all efforts to accommodate the needs of law enforcement. Please contact your local Crime Laboratory to inquire about analysis of evidence related to non-felony offenses.

**Table 30-2**  
**Submissions: Hygiene Lab or Crime Lab**

<b>Offense</b>	<b>Hygiene Lab</b>	<b>Crime Lab</b>
<b>Driving under the influence (DUI) Type</b> Impaired by alcohol and/or other drugs. Includes snowmobiles, motorboats, and ATV's.	ALL OFFENSES Including great bodily harm, vehicular homicide.	ONLY FELONIES ACCEPTED
<b>Death Investigations</b>	Suicides & routine death investigations. Submission is not limited to coroner or medical examiner; WSLH will receive samples in any death investigation.	Death is suspicious and possible FELONY CHARGES pending.
<b>Probation and Parole Violations</b>	Initial charge must be a MISDEMEANOR. <b>FEE is required.</b>	Initial charge must be a FELONY.
<b>Crimes of Violence</b> Domestic Abuse, Drug Facilitated Sexual Assaults, Weapons Charges	NOT ACCEPTED	ACCEPTED
<b>Controlled Substance Cases</b>	NOT ACCEPTED	MUST BE A FELONY Biological samples alone are not sufficient for possession charges.

## VII. Toxicology Laboratory Contact Information

The Madison laboratory and the Milwaukee laboratory both have Toxicology Units; the Wausau laboratory has a Blood Alcohol Unit. The addresses and phone numbers are listed in the Introduction.



The State Lab of Hygiene can be contacted at:

Wisconsin State Laboratory of Hygiene (WSLH)  
2601 Agriculture Drive, P.O. Box 7996,  
Madison, WI 53707-7996  
(608) 224-6241  
<http://www.slh.wisc.edu/forensic>

Contact information for the Wisconsin Veterinary Diagnostics Laboratory can be found at <http://www.wvdl.wisc.edu>.

In addition to the state laboratories there are also independent laboratories which are approved to analyze blood and urine specimens for alcohol under Wisconsin Statute 343.305(6)(a). A list of all approved laboratories can be found at [http://dhs.wisconsin.gov/rl\\_DSL/Labs/LABSintro.htm](http://dhs.wisconsin.gov/rl_DSL/Labs/LABSintro.htm) or by calling the Wisconsin Department of Health and Family Services, Division of Supportive Living, Clinical Laboratory Unit at (608) 267-9862.

## VIII. Toxicology Kits

The WSLH provides blood and urine collection kits intended for use in driving under the influence (DUI) related offenses and are free of charge for these purposes. See above for their contact information.



**Fig. 30-2** Example of a WSLH blood collection kit.

# Notes

# Poisoning

**S**ome poisonings are readily recognized and present no problem in detection. At times, however, poisoning symptoms resemble those of natural illnesses, and the occurrence of the poisoning may be difficult to detect. The investigator should always be alert for clues which may suggest poisoning, whether it is intentional or accidental.

**Caution:** Observe protocols relating to the collection of evidence.

## Poisoning - Human

### I. Procedure Relating to the Scene

Thoroughly search the immediate area for containers (medicine bottles, drinking glasses, spoons, hypodermic syringes, needles, aerosol containers, etc.), taking care to preserve any fingerprints which may be on the evidence. The last food items consumed may be considered evidence in some poisonings (see Section III, A.5 below).

### II. Procedure Relating to Victim

- A. Note any symptoms (vomiting, shivering, unconsciousness, unusual color, or rigor mortis).
- B. If toxic symptoms are closely associated with the ingestion of food or drink, collect a reasonable portion (8 ounces) of these items.
- C. If victim is living, have a physician recover blood and urine specimens.
- D. If victim is dead, a complete autopsy must be performed. Tissue and other specimens should be collected and packaged. These specimens should include:
  1. Blood. Collect at least 20 milliliters (mLs) in gray-top blood tubes. If prescription drugs are suspected, an ad-

ditional 5-10 mLs of blood should be collected from a peripheral site (e.g. femoral vein) in a gray-top blood tube.



**Fig. 31-1** Grey top blood tube

2. Urine. Collect entire contents of the bladder in a glass jar. If urine volume is less than 15 mLs or is unavailable, collect a kidney sample (100 grams in a glass jar).
3. Stomach contents. Collect the entire contents, or measured portion of the stomach contents in a glass jar. If only a portion of the stomach contents is submitted, mark what fraction is submitted (e.g., 1/2 of total contents submitted) on the label.
4. Liver. At least 100 grams in glass jar (approximately 3-4 oz.).
5. Hair. Collect a large sample (see [Chapter 23 - Hairs and Fibers](#)).
6. Ante mortem blood and urine. In cases involving significant hospital stays collect the earliest samples drawn by medical personnel.
7. Eye fluid (vitreous humor). 1-5 mLs in a gray-top blood tube.
8. Bile. Collect 5 mLs in a gray-top blood tube.

### III. Supplementary Information Procedure

- A. Record information from victim's family or other sources:
  1. Name, age, sex, and weight of victim.
  2. Date and approximate time victim was last seen.
  3. Type and quantity of substance that may be related to the cause of death.
  4. Other drugs or medicines available to the victim in the three days prior to the onset of symptoms. Document the contents of the medicine cabinet. For prescription drugs include the prescription dates, the amount prescribed (e.g., number of pills) and amount of medicine remaining.

5. If death was sudden, obtain details of last known food or meal.
  6. List date and time deceased was found.
- B. Record/collect the following medical information:
1. Victim's medical history, including a list of all medications used.
  2. Attending physician's observations and treatment of victim prior to death.
  3. The autopsy report including the pathologist's observations and conclusions.
  4. If resuscitative attempts were made, list all drugs administered by medical personnel.

## Poisoning - Animal

Cases of non-felony animal poisoning should not be submitted to the Laboratory. The Wisconsin Veterinary Diagnostic Laboratory handles animal poisoning cases. Their telephone number is (608) 262-5432.

# Notes

# Controlled Substances

*Forensic Scientists in the Controlled Substances Unit detect and analyze controlled substances and other drugs in plant materials, powders, liquids, capsules, tablets, cigarettes (joints), cigars (blunts) and many types of paraphernalia such as scales, spoons, straws and smoking devices. They also assist agents from the Division of Criminal Investigation (DCI) in assessing, processing and collecting evidence at clandestine drug laboratories.*

## I. Submission of Drug Evidence

Proper collection, packaging, storage and submission of drug evidence help ensure the integrity of the evidence for forensic analysis. Each type of evidence requires specific handling precautions that need to be followed when submitting drug evidence to the laboratory for analysis.

There are different types of drugs in many forms. Some of the commonly seen types are listed below.

### Marijuana

The most common plant material submitted to the Laboratory for analysis is marijuana. Marijuana contains the controlled substance tetrahydrocannabinol, commonly known as THC. Upon seizing the evidence, the officer should perform a Duquenois-Levine color test on the suspected plant material. A positive color test should be sufficient for probable cause at a preliminary hearing.

For simple possession cases, the dried plant material should not be submitted to the Laboratory for a chemical analysis **until a trial date has been set**. Associated paraphernalia such as pipes, cigarette papers and roaches often found with suspected plant material should only be submitted to the Laboratory if they are essential to the case. Seeds do not contain THC and thus are recommended against being submitted.



**Fig. 32-1** Marijuana in PVC Pipes



**Fig. 32-2** Marijuana Bes



**Fig. 32-3** Brick of Hash

Fresh plant material such as recently harvested marijuana plants needs to be dried prior to packaging or packaged in breathable containers such as brown paper bags to allow the material to dry safely. If fresh or wet plant material is packaged in airtight containers such as plastic bags, it will rot fairly rapidly like wet silage, forming a soft, watery mass with a foul pungent odor. In addition, the material can become moldy. Moldy plant material is a **potential health risk**. The time to **dry plant material is immediately upon confiscation**. If your agency confiscates fresh plant material, the following should be done:

1. Air dry the material in a well-ventilated, secure area until thoroughly dry.
2. After obtaining the weight of the evidence, take representative samples of the **dried** plant material from each batch (container, package, etc.) and seal them for transmittal to the Laboratory (see Section V. Drug Packaging below). A few grams of material from each item are sufficient for analysis.
3. Package the dried plant material in a sealed paper bag or envelope to further reduce the possibility of spoilage.
4. In order to be counted as a plant, there must be intact leaves, stems, and roots. If the plant count and analysis is important to the case, plants must be packaged separately.



## Khat



Fig. 32-4 Bundles of Khat

Khat is plant material that is native to eastern countries of Northern Africa. Khat is usually seen as tied bundles which consist of plant shoots with green leaves wrapped in a large plant leaf. Khat contains two controlled substances, cathinone and cathine. Without the proper preservation, cathinone (Schedule I) will break down into cathine (Schedule IV). **To help prevent this breakdown and preserve the material, khat should be frozen soon after confiscation.**

## Other Plant Material

Other plant materials containing controlled substances may also be encountered. Common examples are peyote cactus that contains mescaline, psilocybin mushrooms and opium poppies. Plant material of this nature may be submitted to the Laboratory for analysis anytime after the plant material has been thoroughly dried. Additionally, synthetic cannabinoids sold in a variety of herbal products such as “K2”, “Kush”, and “Mr. Smiley” have become prevalent. Due to the continually changing components in these products, they should be submitted to the Laboratory for analysis. As of April 25, 2014, many of these synthetic cannabinoids were added to Wisconsin Statute 961 by specific listing or structural classification.



Fig. 32-5 Peyote Buttons  
(Mescaline)



Fig. 32-6 Psilocybin  
Mushrooms



Fig. 32-7 Opium  
Poppies

## Powders and Chunky Material

Cocaine, cocaine base (crack) and heroin are controlled substances usually seen in a powdered or chunky form. These drugs are commonly encountered in colors ranging from white to off-white, tan to brown. Cocaine is sometimes seen as compressed bricks of white to off-white powder (kilo bricks), with logo marking and multiple layers of tape and plastic packaging.

Other substances that may be seen as powders, chunks, or crystalline material include controlled substances such as methamphetamine, methylone, and alpha-PVP. In recent years, there has been an emergence of synthetic cathinones commonly referred to as “bath salts”. These synthetic cathinones may be marketed in a variety of products such as “Ivory Wave”, “Vanilla Sky” and “Cloud Nine” and are often sold as bath salts, plant food, or jewelry cleaner with labeling including “not for human consumption”. Due to the continually changing components in these products, they should be submitted to the Laboratory for analysis. As of April 25, 2014, many of these synthetic cathinones were added to Wisconsin Statute 961 by specific listing or structural classification.

Recently fentanyl and fentanyl analogs have also be seen in a powdered or chunky form. These compounds are very potent opioids and readily absorbed through the skin. Special precautions should be taken when handling cases suspected to contain fentanyl including proper protective equipment such as gloves and masks. It is also recommended that your agency have a safety plan in place for accidental exposure to fentanyl.

Upon seizing the evidence, the officer should perform the appropriate color test(s) for the suspected material (see Section II. Color Testing below). If the confiscated evidence is in trace or residual amounts, avoid conducting any color tests; submit the items directly to the Laboratory if analysis is necessary.

## Liquids

Phencyclidine (PCP), Gamma-Hydroxybutyric Acid (GHB), Gamma-Butyrolactone (GBL), 1,4-Butanediol and anabolic steroids are controlled substances usually seen in liquid form. Steroids usually are available in pharmaceutical preparations with labels often in a foreign language. As liquids are usually transported in glass containers, care while packaging and shipping must be exercised to prevent the container from breaking.



Fig. 32-8 Steroids



Fig. 32-9 Liquid PCP

## Pharmaceuticals

Pharmaceutical tablets, capsules and patches which are seized can frequently be identified through their markings (imprint codes). These tablets are well defined and marked. An officer should consult references such as the *Physicians Desk Reference*, *Drug Identification Bible*, *Pharmer.org*, *Drugs.com*, or *Identadrug online* to determine if the evidence is a controlled pharmaceutical preparation. The markings on the suspected pharmaceutical tablets must compare thoroughly to reference picture or description before conclusion. Alternate sources of information about marked tablets, capsules and patches are area pharmacists, local or regional poison control centers or the Laboratory. Non-controlled pharmaceuticals should not be submitted to the laboratory.

## Illicit Tablets



Fig. 32-10 Illicit Tablets Submitted as “Ecstasy”

Illicit tablets often contain many types of controlled substances and these appear in many colors and logos. Illicit tablets have traditionally contained MDMA. However, laboratory analysis of these tablets have found other controlled substances such as MDA, BZP, methamphetamine, ketamine, MDPV and GHB, often in combination with MDMA and other adulterants. It is recommended that officers submit illicit tablets to the Laboratory for analysis to determine the specific controlled substance(s) present.

## Syringes and Other Sharps

Because of the dangers for contracting bloodborne diseases through an exposure to a contaminated needle or syringe which has been used for injecting drugs, extreme caution needs to be exercised when handling, packaging, storing and submitting these items as evidence (see [Appendix A - Bloodborne Pathogens](#)). **DO NOT SUBMIT** syringes or needles to the Crime Laboratory for analysis **unless absolutely necessary**. If syringes, needles, razor blades or any other sharp items are to be submitted to the Crime Laboratory, be sure to handle them with **extreme care** and to package them in sealed **puncture proof and biohazard labeled** containers.

## II. Color Testing

Color test pouches are available from commercial suppliers that provide drug investigators with preliminary information regarding the nature of a suspected controlled substance. The tests results are presumptive. Although the test results, when performed by an officer in the field, are not sufficient to serve

at trial as definitive identification of a controlled substance, they often will suffice for probable cause at the preliminary hearing. In many instances, the color testing results can be used to obtain search and arrest warrants. Therefore, it is crucial that these tests always be performed according to the manufacturer's instructions.

In cases where only small amounts of material are present, **never use more than  $\frac{1}{10}$  of the material for the test.** If there is not enough material to run the test, skip the color test and submit the item to the Laboratory for analysis.

**DO NOT send the used plastic pouches containing the results of color tests to the Laboratory with the evidence. These pouches contain chemicals that may leak and contaminate your evidence.** Used pouches should be disposed of according to the manufacturer's instructions.

### III. Pseudo Drugs

The State Crime Laboratory in Milwaukee supplies pseudo-cocaine and pseudo-heroin used in narcotic canine training. The pseudo drugs are available in pound and half-pound sizes only. Agencies interested in obtaining pseudo drugs need to request in writing on official letterhead the following:

1. The type and quantity of the pseudo drug needed.
2. The date by which the material is needed. (If possible, no less than ten working days).
3. The name and phone number of the contact person and the billing address of the agency making the request.
4. The shipping address, if the items are to be sent via FedEx or UPS.

Send the request to the following address:

WI State Crime Laboratory  
Attn: Chemistry Supervisor  
1578 S. 11<sup>th</sup> Street  
Milwaukee, WI 53204

## Controlled Substances 32

The requesting agency will be billed with an invoice, the total amount to be remitted within thirty days.

### IV. Latent Prints/DNA on Drug Packaging Materials

When it is anticipated that latent print examination or DNA testing will be needed on drug packaging materials, **the drug item should be separated from the original packaging when it is reasonable to do so.** The drug item (powders, plant material, etc.) and the packaging should be sealed in separate containers prior to submitting to the Laboratory for analysis. (See Section V for repackaging guidelines.) Notify the Laboratory that latent print and/or DNA analysis is requested in addition to drug analysis **at the time the evidence is submitted.**

The contents of each evidence container should be itemized on the transmittal form for proper receipting of the evidence. **Nonspecific terms such as “drug packaging” and “paraphernalia” should be avoided.** Transmittal information should include item by item notation as to what analyses are being requested. For example, the transmittal should read as illustrated in Figure 32-11

Exhibit #	Qty	Item Description and Source
1	5	smoking pipes (Drugs & Prints)
2	10	zip top plastic bags (DNA & Prints)
3	2	drug packages consisting of duct tape, heat-sealed plastic and plastic wrap (Prints)

Fig. 32-11 Example of transmittal item descriptions

**NOTE:** All persons handling these items should wear gloves as a safety precaution and to prevent their own prints or DNA from being deposited onto the evidence.

### V. Drug Packaging

If items of drug evidence require repackaging [i.e., separation of original packaging for latent print or DNA analysis (see Section

IV) or submission of representative samples to the Laboratory], use the following packaging guidelines.

- Powders and plant material should be repackaged in paper packets, envelopes or paper bags. Ensure that the drug evidence does not leak from any seams or seals. **Do not** place small amounts of powder or plant material in heat-sealed plastic sleeves or large plastic bags. The static electricity generated by the plastic makes recovery of the material difficult.
- Liquids can be left in their original container if the container is leak proof and can sufficiently contain the liquid. These original containers should be placed in a secondary leak proof container. Liquids in metallic containers should be transferred to a glass container. **Never place a liquid directly into a metal container.** If a large quantity of liquid is encountered, submit only a representative sample (approximately 20 milliliters) for analysis. Liquids requiring repackaging should be placed in a glass vial which is then placed in a Nalgene bottle (see Fig. 1-4 in [Chapter 1 - Evidence Integrity](#)).
- Items for DNA examination should always be packaged in paper envelopes or bags or cardboard boxes. All who handle the materials should wear gloves and take proper precautions to prevent depositing their own fingerprints or contaminating with their own DNA.

Please contact the Laboratory if you have any questions regarding the repackaging of evidence.

## VI. Clandestine Drug Laboratories

Domestic clandestine drug laboratories range from crude makeshift operations to highly sophisticated and technologically

advanced facilities, some of which are mobile. They can be set up anywhere and are often found in private residences, motel and hotel rooms, house trailers, houseboats, campgrounds and commercial establishments. Often these laboratories are hidden in nondescript houses or barns in remote rural areas. Some of these facilities contain sophisticated surveillance equipment and may be booby-trapped. This may be done to prevent intruders and law enforcement personnel from entering or to destroy any evidence if the facility is discovered.

In recent years, “One Pot” or Shake ‘N Bake” methamphetamine labs have become more prevalent. These types of labs are generally seen as plastic drink bottles (figure 32-12) containing all the necessary components in one reaction mixture. Due to the hazardous and reactive nature of the components involved, these labs create a serious health and safety risk.

**Any law enforcement agency that believes there is a possible clandestine drug laboratory of any type in their vicinity should first contact their regional DCI office for assistance in the investigation.**

**Extreme care and caution should be used whenever investigating or processing a clandestine lab site.** Every precaution should be taken as the substances used in the production of controlled substances may be **caustic, corrosive, carcinogenic, poisonous, irritating, explosive or flammable.** Law enforcement personnel engaged in clandestine drug laboratory investigations and seizures should have specialized training in the investigation of such laboratories, the appropriate health and safety procedures and the use of personal protective equipment.

Clandestine drug laboratories may also involve the removal and proper destruction of large quantities of hazardous toxic chemicals. The disposal of these chemicals is strictly regulated by state and federal environmental protection agencies. The liability for the removal and disposal of these chemical



hazards is often the single largest cost-producing portion of any clandestine lab investigation.



**Fig. 32-12** “One Pot” or “Shake ‘N Bake” methamphetamine lab



**Fig. 32-13** Placards demonstrating hazards of the One Pot method.

# Notes

# Arson

**M**any times it is difficult to ascertain whether a fire was accidental or arson. This is especially true when simple ignition devices such as a match and paper were used to start the fire. Frequently flammable liquids such as gasoline, oil, fuel oil, charcoal lighter fluid, etc., are used as accelerants. If used, and if the fire origin can be determined, it may be possible to detect and classify accelerants.

The Laboratory is equipped with sensitive instruments capable of detecting and classifying trace quantities of volatile hydrocarbons. Detection is not possible if the fire completely consumes the accelerant or if the samples are not from the fire's origin. Because ignitable liquids readily evaporate, great care must be taken in the collection and packaging of fire debris suspected of containing them. Containers of arson evidence need to be air tight to prevent loss by evaporation, and possible contamination. Moisture is not a problem. **Do not air dry arson evidence.**

**Caution:** Observe laws relating to the collection of evidence.

In considering whether or not a fire is a case of arson, review the possible motives (financial gain, personal satisfaction, concealment of another crime, revenge or pyromania). The following is a brief general procedural guide for use in investigation of suspected arson cases.

## I. Procedure at Crime Scene

- A. Note (and photograph to scale whenever applicable):
  1. Condition of all locks, doors, windows. If entry has been forced, see [Chapter 16 - Burglary](#) and [Chapter 17 - Building Materials](#).
  2. Origin of fire (one or many sites?).
  3. Identification of igniting material (foreign to the

- scene?).
4. Presence of ignitable liquids by:
    - a. odor of petroleum products, paint solvents, alcohol, etc.
    - b. stains on floor or other material
    - c. evidence of explosions not due to heat (shattered glass)
    - d. unusual burning patterns (splashed areas or trailers)
    - e. rapid spread of fire not explainable by structure, weather, or other conditions
    - f. smoke not explainable by building materials
    - g. characteristic heavy soot
    - h. unusual flame coloration
  5. Evidence of another crime which the fire might conceal (items stolen, evidence of violence).
  6. Recent similar fires in the vicinity (date, time, location, intended victim).
- B. Collect in separate, airtight containers (e.g., one-pint through five-gallon new, unused, unlined metal paint cans):
1. All igniting devices (fuses, candles, wicks, trailers, rags, etc.).
  2. Charred debris and related material from the origin where the accelerant was placed (container should be one-half to three-quarters full).
  3. Samples of plaster, upholstery, wood or other substances that may have been penetrated by ignitable liquids. Any fresh stains should be collected.
  4. Samples of soil (two to three quarts) which may have been saturated by ignitable fluids (container should be three-quarters full). Soil samples should be refrigerated and submitted to the lab as soon as possible to minimize microbial degradation of ignitable liquid hydrocarbons.
  5. Any trace evidence left by the arsonist such as blood stains, fingerprints, clothing, hair and fibers, etc. (For proper collection procedure see chapters 6, 13, 22,

- 23 pertaining to the specific type of evidence).
6. Any and all tools or pieces of metal at the scene (airtight container not necessary).
  7. Liquids should be collected in airtight clean glass bottles sealed with Teflon®-lined caps or absorbed onto a clean cloth and placed in an airtight container.
  8. Samples of carpeting and/or padding which readily absorb ignitable liquids collected from around the point of origin (in vehicles as well as buildings). **A sample of uncontaminated carpeting and/or padding must be collected separately and submitted for comparison purposes.**
  9. When fire debris consists of carpeting, cloth, plastics, polymers, synthetics or other material, uncontaminated known samples must be collected separately and submitted. Control samples allow the scientist to distinguish between natural or fire produced artifacts and ignitable liquids.
- C. If a container is found that has a flammable label on it and is suspected of being involved in the fire, a container of the same labeling should be purchased from an area store and submitted to the Laboratory. If unavailable, send in the description of the flammable contents from the label.
- D. In cases involving large volumes of ignitable liquids or suspected ignitable liquids, contact the Laboratory for the proper procedures in handling and packaging.

## II. Suspects

Incidental to arrest, with consent, with a search warrant, or with a combination of the above, obtain the following:

- A. Fuels, flammable solvents, tools or starting devices in the suspect's car and home. Submit fire starting devices **only** after they have been deactivated and properly packaged.
- B. Clothing worn at the time of the crime, including shoes (package in clean, unused airtight paint cans or

specifically made fire debris nylon bags).

- C. Any stains from the vehicle's interior if possible. The car may have been involved in transporting the suspect or incendiary materials to or from the crime scene.
- D. Any trace evidence (paint, glass, building materials, etc.) which might connect the suspect to the scene found on the suspect's clothing or in the suspect's car or home.



**Fig. 33-1** New, clean paint cans make ideal containers for preserving evidence suspected of containing accelerants. Cans are available from paint stores or wholesalers.



**Fig. 33-2** Char pattern typical of the use of accelerants. The area where the accelerant is in contact burns hotter and therefore leaves a char pattern that is different from surrounding areas. Door propped open, holes chopped in floors, “trailer” used to direct the fire from one area to another, etc., are all reasons to suspect that a fire is due to arson.

## Explosives, Bombs and Fireworks

*Materials causing an instantaneous disruption of solid or liquid bodies releasing gas, heat or pressure and associated with loud noise when enough pressure, temperature, or shock is applied describes an explosive. The pyrotechnic display often used as an application for entertainment known as fireworks is discussed below after a brief discussion on explosives and bombs defined as explosive devices put together to explode under specified conditions..*

### Explosives and Bombs

When the explosion is the result of a criminal act, a very careful and methodical search of the scene will frequently reveal evidence indicating the type of explosive involved; further, the search may reveal fragments or parts of either the container, the fuse mechanism or a time delay device. The scene should be roped off, guarded, and all nonessential personnel evacuated from the area. The Laboratory, upon request, will assist the law enforcement agencies in properly processing the scene.

In those instances where suspected explosives or explosive devices are encountered, it is suggested that **no attempt be made to move or neutralize the explosive or device**. A local bomb squad or the federal Bureau of Alcohol, Tobacco and Firearms (ATF) should be contacted by telephone and assistance requested. In Wisconsin, ATF has two districts:

- The Eastern District in Milwaukee, (414) 727- 6170
- The Western District in Madison, (608) 441-5050

Because of the danger and complexity involved, no attempt is being made in this handbook to outline safe or recommended procedures to be followed in the handling or neutralizing of suspected explosive materials. The ATF or local bomb squad

## Explosives, Bombs and Fireworks 34

should be informed by telephone as to the nature, type, size, location, etc., of the suspected explosive substance, as well as any other pertinent information. This will then permit the ATF or local bomb squad to make preliminary recommendations regarding precautionary measures which can and should be taken. If explosives are encountered:

**Do not** attempt to neutralize or destroy explosives.

**Do not** turn on any electrical switches.

**Do not** walk or step in any liquid or suspected explosive material.

**Do not** smoke or use matches in area.

**Do not** move any objects.

If a suspected bomb or package foreign to the scene is encountered:

**Do not** move, turn over, or disturb package or suspected bomb.

**Do not** immerse in any liquid.

**Do** evacuate building and immediate area.

**Do not** pick up or handle any detonators or explosives.

**Do not** breathe any vapors which may be present.

Nitroglycerine may cause a very severe headache

**DO NOT** transport suspected explosive devices or bombs to the Laboratory.

**CAUTION:** Electric blasting caps may be detonated by police radio transmission or cellular phones.





**Fig 34-1** Although the destruction caused by a bomb is great, the pieces of the device which survive are surprising. Investigators should be alert to the investigative leads such debris can provide.

## Fireworks

The current law regulating the manufacture, possession, sale and use of fireworks is contained in Wisconsin Statutes §167.10. By definition, fireworks means anything manufactured, processed or packaged for exploding, emitting sparks or combustion, which does not have another common use. Certain devices are specifically excluded from regulation as fireworks, unless controlled locally by city, village or town ordinance. A list of excluded (non-permit) devices is contained in Wisconsin Statutes §167.10. All other devices require a permit for their possession and use.

# Notes

# Appendix A

## Bloodborne Pathogens

*Occupational exposure to blood and other potentially infectious materials place law enforcement officers at risk for infection with bloodborne pathogens. Bloodborne pathogens are pathogenic microorganisms that are present in human blood and can cause disease in humans. These pathogens include, but are not limited to, human immunodeficiency virus (HIV), hepatitis B virus (HBV), and hepatitis C virus (HCV).*

### I. Bloodborne Pathogen Exposure Control Plan

Law enforcement agencies in Wisconsin are subject to the requirements of the Occupational Safety and Health Administration's (OSHA) Bloodborne Pathogen Standard, 29 CFR 1910.1030. This standard has been adopted by the State of Wisconsin (Wisconsin Statutes Section 101.055) for public employees and is enforced by the Department of Commerce's Safety and Buildings Division. The standard requires that an employer having employees with occupational exposure to bloodborne pathogens establish a *Bloodborne Pathogen Exposure Control Plan*. The purpose of the plan is to offer guidelines to minimize chances of exposure to these pathogens. A model exposure control plan is available at [OSHA.gov](https://www.osha.gov).

Topics the BBP Exposure Control Plan should include are

- engineering controls and work practices
- recordkeeping
- personal protective equipment
- housekeeping schedules
- use of biohazard labels
- training and information on the types of exposures
- hepatitis B vaccinations
- post-exposure evaluations

It is your employer's responsibility to offer hepatitis B vaccinations at no cost. Vaccination is not mandatory and you may refuse. If you later change your mind, vaccinations must remain available at no cost.

A basic premise of the plan is the use of **Universal Precautions**. This means **all** human blood and other potentially infectious materials (OPIM) are treated as if known to be infectious for HIV, HBV and other bloodborne pathogens. Other potentially infectious materials include, but are not limited to:

- seminal fluid
- pleural fluid (lungs)
- vaginal secretions
- pericardial fluid (around heart)
- cerebrospinal fluid
- peritoneal fluid (abdominal)
- synovial fluid (joint)
- amniotic fluid (around fetus)
- human tissue

Feces, nasal secretions, sweat, tears, vomit and urine (when they are not contaminated with blood) are not addressed under universal precautions. However, they can transmit other infectious diseases so **caution is advised**. Any body fluid must be handled with caution.

### II. General Guidelines to Avoid Exposure

- A. Assess a situation beforehand and wear appropriate personal protective equipment (gloves, mask, goggles, shoe coverings, coveralls, etc.).
- B. Protect eyes, nose and mouth by using goggles and a mask. These provide a barrier to spraying, splashing or aerosol transmission of infectious materials.
- C. Gloves minimize the risk of infectious materials entering the body through a cut or other skin lesion. Most latex gloves have microscopic "holes" and openings. Double gloving (wearing two pair of gloves at the same time) and changing gloves frequently aids in protection.

- D. Wash your hands after removing gloves. Frequent hand washing is a good hygiene and safety practice.
- E. Items that are soaked with blood or other body secretions should be carefully air dried. Dry in a manner that minimizes the exposure of other staff to the liquid or dried material.
- F. Do not assume that a dried sample is risk-free. Current research indicates that the infectious activity of some organisms persists **more than several days** after drying.
- G. Minimize or avoid direct handling of contaminated sharp or pointed objects. Collect syringes in puncture-resistant, leak-proof containers and attach a biohazard label. Never shear, break or bend a contaminated sharp.
- H. Smoking, drinking or eating at a crime scene is hazardous. Avoid these activities when handling evidence.

# Appendix B

## Collection Kits

*The following information is provided to assist law enforcement in preparing various evidence collection kits. These kits may be modified to best fit an agency's resources and expertise. Any questions or difficulties obtaining the items listed below, please contact the Laboratory in your service area for assistance.*

### I. General Collection Kit

This kit contains a variety of packaging options and items for documentation and collection of physical evidence at a crime scene. A toolbox with two or more compartments can be used to contain the following:

- Sharpies
- Ink Pens
- Razor Blades
- Scissors
- Disposable Tweezers
- 1 oz. Dropper Bottle of Distilled Water
- Coin Envelopes
- Sterile Swabs
- Swab Boxes
- Methanol Soluble Trace Evidence Tape
- Mikrosil™ Casting Putty for Tool Mark Impressions
- 25' Tape Measure
- Variety of Paper Bags
- Biohazard Labels
- Weighing Paper
- Evidence Tape
- Large Stapler
- Box of Staples
- Variety of Manila Envelopes
- Syringe Tube
- 2 and 4 oz. Specimen Jars
- Cardboard Slide (Pill) Boxes

## II. Fingerprint Processing Kit

This kit contains a variety of fingerprint powders, brushes, lifting media and backing cards for lifts. (See [Chapter 13 - Latent Prints](#) and [Chapter 14 - Major Case Prints](#).) A toolbox with two or more compartments can be useful to separate the powders from the other contents of the kit. This can prevent lift cards and tapes from being damaged by stray powder. As an added precaution, powder jars should be tightened periodically to prevent a jar from opening accidentally. This can occur to jars stored in vehicles over a period of time due to the movement of the vehicle.

- Black and Grey Magnetic Powder
- Black and Grey Fingerprint Powder
- 2" and 4" Rolls of Lift Tape
- Gelatin-Type Lift Tape
- Fingerprint Brushes
- Wand for Magnetic Powders
- Disposable Tweezers
- Adhesive Scales
- White Backing Cards
- Black Backing Cards
- Clear Acetate Sheets
- Dust/Mist Respirator Masks
- Ruler
- Pad of Elimination Print Records
- Ink Pad (for Elimination Prints)
- Gloves
- Magnifier

## III. Casting Kits

These kits may be used for casting tire and footwear impressions at a crime scene (see [Chapter 12 - Footwear and Tire Impressions](#)).

### Dental Stone Kit

- Prepackaged Bags of Dental Stone
- Ziplock Plastic Bags
- Bulk Dental Stone
- Measuring Cup for Bulk Dental Stone and Water
- Snow Print Wax
- Forms
- Flexible Mixing Bowl(s) or Containers
- Metal Stir Rod
- Deflector (Large Spoon)
- Ruler
- Hand Sifter
- Spray Bottle
- Water Jug
- Bottle of Distilled Water
- Instructions for Use
- Transmittal Form

## Sulfur Kit

- Sulfur
- Heating Mantle
- One-Gallon Unlined Paint Can
- Ruler
- Deflector (Large Spoon)
- Dust/Mist Respiratory Masks
- Heat-Resistant Gloves
- Metal Stir Rod
- Goggles
- Forms

## IV. Kits Available from the Crime Laboratory through Document Sales and Distribution

The following kits provided by the Laboratory are available at <https://docsales.wi.gov>.

### Sexual Assault Evidence Collection Kits

Named the “Medical-Forensic Evidence Collection Kit” as a result of collaborative review by DNA Supervisors and Sexual Assault Nurse Examiners (SANE), the kit is still referred to as the Sexual Assault Evidence Collection Kit. The kit was redesigned to offer a single kit for both male and female, and/or suspect and victim. The Sexual Assault Evidence Collection Kits (see [Chapter 7 - Sexual Offenses](#)) are available at no charge..

Sexual Assault Evidence Collection Kit - [1205-15D](#)

Though not provided in the Sexual Assault Evidence Collection Kit, blood and urine samples are still needed when date rape drugs are suspected. For more information, see [Chapter 30 - Toxicology](#).

### Biological Specimens Kits

Biological Specimens Kits are also offered at Document Sales. The kit is designed for either victim or suspect specimen collection and are available at no charge (see [Chapter 6 – DNA Evidence and Standards](#)). Contents include:

- (5) Packages Each Containing Two Sterile Swabs
- (5) Swab Boxes
- (5) Individual Envelopes
- Pair of Gloves

Biological Specimens Kit – [1206D](#)



## DNA Databank Buccal Swab Collection Kits

Wisconsin DNA Databank Buccal Swab Collection Kits, including a postage-paid return envelope, are available at no charge to criminal justice agencies. Use these kits to collect DNA samples for inclusion in the DNA Databank. These kits can be used for the collection of convicted offender samples as well as violent felony arrestees. **These kits are not for the collection of evidence.**

WI DNA Database Buccal Swab Collection Kits:

- ( 25 pack) – [1209A](#)
- ( 50 pack) – [1209B](#)
- ( 75 pack) – [1209C](#)
- ( 100 pack)– [1209D](#)

For more specific information on kit use see [Chapter 8 DNA Databank](#).

## V. Other Recommendations

- Personal Protective Equipment (e.g., Gloves, Dust/Mist Respirator Masks, Goggles, Shoe Covers, Overalls)
- Large Paper Evidence Bags
- Unlined Paint Cans
- Cardboard Evidence Boxes (e.g., Handgun and Long Gun Boxes)
- Plastic Cable (Zip) Ties
- Sharps Storage Containers
- Flashlights
- Forms: Crime Laboratory Transmittal, Evidence Inventory Sheets, Photo Log, Video/Audio Slate
- Physical Evidence Handbook
- Evidence Markers
- Electrostatic Dust Print Lifter and Metallic-Backed Mylar Film
- Metal Detector
- Portable Lighting

## Autopsy Kits

Autopsy kits are no longer available through the State Crime

# Appendix C

## Evidence Submission Guidelines

*The following guidelines are presented and current at publication and are subject to change as necessary.*

The guidelines that follow are listed by laboratory section. The intent of these guidelines is to focus laboratory resources on performing analyses and examinations on the most probable items of evidence in each case. These guidelines were developed based on experience and forensic analysis of evidence in a large number of cases. These experiences have allowed us to determine the most effective analysis process.

By partnering with you, our customer, on the most probable forensic evidence first, rather than sending in all evidence (regardless of probative value) in the beginning, we can provide investigative results in a more timely fashion. You may then submit additional evidence later if required for investigative or judicial purposes.

**Please remember that these are guidelines and we are fully aware that they may not apply to every case. We encourage you to call the laboratory in your service area with any scenario you encounter that does not fit these guidelines and ask for a laboratory supervisor or the laboratory manager. We will always do our best to address the special needs of your case.**

**Thank you for your assistance in this process. Customer service is fundamental to our mission of providing high quality forensic analysis in a timely fashion and we think these guidelines will help us achieve that goal.**

General Evidence Submission Guidelines

- Submission of items of evidence shall be connected with felony investigations as per WI Statute §165.75.
- Misdemeanor cases will be considered on a case-by-case basis for controlled substances analysis and other unique circumstances.
- Evidence connected to local ordinance violations and civil matters will not be analyzed by the crime laboratory.
- The following guidelines set the standard requirements for routine submission of forensic evidence to Wisconsin State Crime Laboratory Bureau.
- When multiple sections of the laboratory are involved, the submitting agencies should contact either a laboratory supervisor or manager of the Wisconsin State Crime Laboratory Bureau in their service area for guidance. Processing by one section of the laboratory may have a detrimental effect of the other section(s) ability to process the item(s) of evidence.
- Please notify the crime laboratory if evidence analysis is no longer needed.
- Fingerprinting and DNA analysis on items removed directly from a person's body or clothing is generally not of forensic value and may not be analyzed unless there is a specific investigative need.
- Items requiring fingerprint analysis should be packaged separately from drug evidence. If a case requires fingerprinting of the bags the suspected drugs were in, please separate them prior to submission and list them as separate items on the transmittal sheet.
- The CLB requests that forensic evidence needed for analysis be submitted at least a month prior to the trial date whenever possible so that the crime laboratory has time to complete analysis. If it is a rush case, please limit evidence to one item (if possible) and give us as much notice as possible. If analysis is needed for pre-trial, please notify the crime laboratory as soon as possible and include the court date.

## **DNA Evidence Submission Guidelines**

1. DNA testing may be completed when an association is established from probative evidence. For example, an associa-

tion is established between a subject and a victim. A factual scenario must be provided with the submitted evidence. The scenario will establish the value of each item as to its likelihood to provide probative results or an investigative lead. If appropriate DNA standards are not presented at the time of initial submission, analysis could be delayed.

2. The type and number of items accepted per submission is based on case type. For all cases, known standards from victim(s) or subject(s) will not count against the number of items that may be submitted. An item is expected to be comprised of one piece of evidence. If items are received packaged together, the number of items in the package will be considered to be the number of items submitted (i.e. pants, shirt and shoes packaged together will be considered three items).

### **a. Sexual Assaults**

- The first submission is limited to a sexual assault evidence kit (recovered from a victim and/or subject) plus one pair of underwear, and one condom.
- If the kit is negative, additional items such as clothing or bedding may be submitted in a separate submission.
  - Second and subsequent submissions are limited to 5 items per submission. Based on discussions with the submitting agency and/or prosecuting attorney, every attempt will be made to focus on probative evidence.
- If the kit is positive, no additional items will be accepted for DNA, unless after discussions with the investigator and prosecutor it is determined that case circumstances (such as multiple subjects or the DNA detected is attributable to a consensual partner) dictate the need for additional processing.
- Large items such as mattresses and car seats are not to be submitted. These types of items of evidence will only be processed when no other probative evidence exists. If necessary, the surface material may be cut and submitted for analysis. Prior to submission of these items contact the Laboratory DNA Supervisors for further direction.

- Buccal swab standard(s) from any consensual partner(s) who had sexual contact with the victim within 72 hours of evidence collection must be submitted.
  - Standards from consensual partners up to 120 hours prior to evidence collection may be requested at a later time. These standards do not count toward the number of items allowed per submission.

## **b. Homicides**

- DNA evidence is limited to a maximum of 10 items per submission.
- If probative DNA results are obtained from any of the 10 items in the initial submission, additional items may not be examined, unless case circumstances dictate the need for additional processing.
- If no probative results are found on the first submission, the next tier of probative items (maximum of 10) may be submitted.

## **c. Burglary/Property Crimes**

- The first submission is limited to a maximum of 3 items for DNA—typically blood sample(s) from the scene, or items that may have been left at the scene (cigarette butt, item of clothing, etc).
- If a profile is developed additional items may not be examined, unless case circumstances dictate the need for additional analysis.

## **d. Other Case Types (robbery, assault, etc.)**

- The first submission is limited to a maximum of 3 items for DNA.
- If a profile is developed additional items may not be examined, unless case circumstances dictate the need for additional analysis.
- Items of evidence directly taken from a defendant in a possession case (i.e. body cavity, pockets, or waistband) may not be processed for DNA.

## **e. Criminal Parentage Cases**

- Submissions must include a buccal swab standard from the mother or alleged mother, father or alleged father, the child or the product of conception (frozen with no

preservatives).

- No partial submissions will be accepted, unless dictated by case circumstances (such as mother is deceased or maternity is in question and the father is unknown).

### 3. Touched Evidence

- a. Touched evidence is defined as evidence which has no visible staining and would contain DNA that only results from touching an item with the skin. Touched evidence does not include cigarette butts, swabbing from cans, bottles, straws or other items in which the substance being tested is most likely saliva. Touched evidence does not include items submitted for wearer of such shirts, shoes, hats, etc. where there is probability of prolonged contact.
- b. Touched evidence will be accepted for possible STR DNA analysis when there is a high degree of likelihood that the evidence submitted will provide probative results or investigative leads. A high degree of likelihood may be established by means of witness corroboration, visual monitoring systems, or sound deductive reasoning.
- c. Touched evidence will be processed on violent crime cases only, absent extenuating circumstances.
- d. Touched evidence accepted will be processed only when no other probative evidence exists.
- e. Touched evidence accepted will be processed for DNA only if it has not been previously processed by another discipline.
- f. Touched evidence will be processed for DNA only if it has been properly stored and handled.
- g. Items submitted for touched evidence processing will comply with existing policy relating to the number of items of evidence that may be submitted based on case type.
- h. Charred or burnt evidence and fired cartridge casings will not be processed for DNA.
- i. Touched evidence collected from the floor, countertop, doorknob/handle, or payphone of a public place will not be processed for DNA, unless there is direct evidence that the

object was touched/handled by the subject.

- j. Elimination standards must be submitted with touched evidence where appropriate (i.e. owner of hijacked vehicle).
- k. It is recommended that touched evidence be collected using DNA free swabs.

## **Chemistry Evidence Submission Guidelines**

- If the evidence submitted for controlled substance analysis has more than one date-of-offense we ask that the submitting agency prepare a separate transmittal sheet for each date of offense.

## **Weight Limits**

- Generally the laboratory will work to the highest statutory weight limit for each type of drug submitted.
- If the drug does not have a statutory weight limit, or the weight of the drug does not reach the lowest statutory weight, only one unit will be tested.
- The laboratory will utilize a scientific sampling plan known as hypergeometric sampling. This plan is based on a mathematical formula which ensures uniformity in the sampling process and meets the CLB accreditation standards.

## **Plant Material**

- Please do not submit wet plant material to the laboratory. Wet plant material will mold which results in a health hazard and loss of the substance of interest.
- Seal recently dried plant material in paper bags.
- Submit a sample (approximately 1 gram) from a large plant instead of the entire plant. Package and seal each plant, or plant sample, separately. **DO NOT SUBMIT ONLY THE ROOT BALLS OF A PLANT.** The root balls do not contain any statutory controlled substance.
- Please contact the laboratory in your service area for guidance to determine the number of plant samples needed for submission.
- Hypergeometric sampling may be used for large grow operations. Please contact the laboratory for guidance.

### Syringes

**\* NOTE: Syringes will generally not be accepted if there are other items of evidence in the case. \***

**A syringe may be submitted if it is the only item in the case, or the only item connected to a subject. To submit a syringe, follow these four steps.**

- 1) Package the syringe in a puncture-proof tube.
  - 2) Mark it as a biohazard.
  - 3) Clearly state on the transmittal form that the item is a syringe.
  - 4) Take all necessary safety and blood borne pathogen precautions when handling syringe(s).
- If a syringe contains liquid, package the item to preserve and contain the liquid also. Only the liquid will be analyzed.
  - Do not package liquids in metal cans, pill bottles, or plastic bags. Use a container appropriate for liquids (e.g., screw-top vials or specimen jars). Please contact the laboratory in your service area for guidance.

### Evidence submitted from suspect Clandestine Laboratories

- Always call DCI for advice on how to proceed with a suspected clandestine laboratory. A map with service areas and contact information is located on the DOJ website.
- Only properly stabilized samples from suspected clandestine laboratories may be submitted to the crime laboratory.

### Pharmaceuticals and Clandestinely Manufactured Tablets

- Non-controlled pharmaceuticals should not be submitted to the laboratory.
- If non-controlled pharmaceuticals are found within a case being worked, they will be examined visually using pharmaceutical logo identifiers to indicate the substance present, no other analysis will be performed absent a compelling investigative need.
  - Controlled pharmaceuticals will be examined visually



using pharmaceutical logo identifiers. A representative sample for each drug type per case will then be analyzed further to identify the controlled substance present.

- If an item contains tablets or capsules that do not have a pharmaceutical logo identifier and are visually consistent (same color, shape, and size), a representative sample of the tablets or capsules may be examined and reported on.
- A representative sample of the tablets may be examined and reported on for clandestinely manufactured tablets that are visually consistent (same imprint and color).
- Note: If the drug identified in the pharmaceutical or clandestinely manufactured tablet has a statutory weight limit, the laboratory will work to the highest statutory penalty.

## **Residues/Drug Paraphernalia**

- If weighable material is present in other items, please do not submit paraphernalia or residues.
- If there is no weighable material, only one residue item per substance type will be analyzed (e.g., one plant residue and one powder residue).
- If a residue or paraphernalia item meets the guidelines for submission, please do not field test the material. Submit it to the laboratory for testing.
- Please do not use the general phrase “various or miscellaneous paraphernalia”. Clearly describe the item(s) on the transmittal.

## **Toxicology Evidence Submission Guidelines**

- Submission of all items of evidence shall be connected with potential felony investigations as per WI Statute §165.75 with the following exceptions:
  - Fourth offense or above OWI
  - Bail jumping

- o Endangering safety by use of a dangerous weapon
- First through third offense OWI should be sent to the WI State Laboratory of Hygiene.
- If a case is suspected to be charged under the Len Bias Act-please let the laboratory know upon submission.

The best blood collection tubes for toxicology samples are gray top tubes. These tubes contain the requisite preservative and anti-coagulant. Tubes with purple tops are also acceptable but the preservative in those tubes may limit certain types of testing.

*A sufficient volume of blood is necessary to complete toxicological testing. Two tubes filled at least to 50% will be adequate to accommodate multiple drug testing requests. Too little sample may limit what tests the laboratory can perform, and it may be necessary to decide which tests are most important and which can be delayed until it is known whether or not there is enough sample. Please contact the lab if there are questions regarding the volume of blood collected.*

Urine samples should be placed in a watertight sealed container if possible. Otherwise be sure the specimen container is closed tightly and placed in a sealed plastic bag to hold any urine that might leak out of the container.

Please notify the laboratory if the sample is associated with bail jumping and there are restrictions such as “no alcohol” or “no drugs.” If drugs are suspected, be sure to tell us what drugs you suspect.

When you suspect the use of a single drug, such as THC, cocaine, and heroin, please request targeted testing for those substances as a full drug panel is not necessary.

## Latent Prints Evidence Submission Guidelines

### 1. For nonviolent crimes

- A maximum of 15 items for latent print processing will be accepted per submission.
  - Known standards from victim(s) or subject(s), latent lifts and image media (CD/DVD) are excluded from this submission guideline and have no submission limit.
  - An item is expected to be comprised of one piece of evidence (i.e. one object per package). If items are received packaged together, the number of items in the package will be considered to be the number of items submitted (i.e. three baggies packaged together will be considered three items).
  - If no probative results are found on the first submission, the next tier of items (maximum of 15) may be submitted.
- Drugs must be separated from packaging for latent print processing and submitted as separate items.
- Layers of packaging from only one kilo/“brick” of controlled substance (i.e., layers of tape and plastic wrap from one “brick” of cocaine or one “brick” of marijuana) will be accepted per submission.
- Items of evidence **taken directly from a subject** (i.e. body cavity, pockets, or waistband) will generally not be processed for latent prints. You should contact the supervisor to explain the need in such cases.

2. Appropriate elimination standards (i.e. residents of the house, owners/drivers of the stolen vehicle, employees who handled items) should be submitted for all individuals with rightful access to locations and items where latent print evidence is collected. Identification analysts may elect to not enter latent prints into AFIS/NGI without receipt of proper elimination standards.

3. Known standards should be submitted even if the individuals have a record on file.

4. Based on our experience in analysis of small items of evidence measuring less than one square inch in size (see below), we typically do not obtain any usable latent prints.

However, when there is a high degree of likelihood that the evidence submitted may provide probative results or investigative leads, these types of evidence will be examined.

These items would include but are not limited to:

- knotted baggie corners
- miniature zip lock bags
- .22 cartridge cases
- small syringes

In addition, heavily textured or soiled items along with improperly scaled items will not be examined. Exceptions to this guideline will be handled on a case by case basis if the submitting agency can demonstrate the probative value in examining these items.

### **Bloodstain Pattern Analysis (BPA) Submission Guidelines**

Bloodstain Pattern Analysis (BPA) is the examination of the size, shape, distribution, overall appearance and location of bloodstains at crime scenes or on items recovered from a crime scene. These examinations are performed in an attempt to provide an interpretation of the physical events by which they were created.

Proper preservation and documentation of bloodstain patterns is crucial for an effective analysis. Prior to submission of a case for BPA it is required that the submitting agency contacts their regional laboratory to consult with the Crime Scene Response Supervisor or a trained BPA analyst. **The laboratory will only accept cases in which the events occurring during or after the creation of the bloodstain patterns are of forensic or probative value to the submitting agency.** The supervisor or BPA analyst will evaluate the request with the case officer including the case scenario and evidence and/or bloodstain pattern documentation prior to acceptance.

#### **Case Types:**

BPA analysis can be performed on most cases in which blood evidence is present at a scene or on items of evidence;

however, case submissions will be limited to:

- Homicides/Attempted Homicide cases
- Missing Persons cases
- Cases involving great bodily harm (assaults, other case types).

### **Case Documentation Requirements:**

Once a case has been evaluated and accepted by the laboratory for BPA, the following methods of evidence submission/documentation are acceptable for case submission:

- An active or properly preserved crime scene for on site evaluation by the Wisconsin State Crime Laboratory Bureau's Crime Scene Response Team.
- Proper documentation of individual bloodstains and/or bloodstain patterns from a crime scene including sketches, scaled and un-scaled photographs. This submission must also include a detailed account of the nature of the crime and the crime scene, autopsy reports (if applicable) and any eyewitness, victim, or subject accounting of the events.
- Original items of evidence with unaltered bloodstains present for analysis. This submission must include a detailed account of the nature of the crime, scene details, autopsy reports (if applicable) and any eye witness, victim or subject accounting of the events.

Call the appropriate laboratory in your service area with questions, concerns, or comments. Contact information for our three laboratories are listed at the beginning of this handbook.

## Index

### A

Accident reconstruction 195, 197

Address

Crime laboratory *iii*, 251

State Lab of Hygiene 239

AFIS

electronic submission 153

email submission 153

fax submissions 154

FBI search 152

image quality 146, 147

search requests 152

legible prints 134

See also *fingerprints*

Air dry

arson evidence 257

bite mark swabs 75, 206

bloodstains 200

casts 118

clothing 207

condom swabs 77

DNA Databank swabs 85, 86

DNA swabs 66, 74

finger swabs 75

finger nail swabs 75

method

plant material 246

recover blankets or sheets 199, 206

Alcohol

blood alcohol 228, 230, 233, 235, 238

urine alcohol 228, 232

Ammunition

bearing print 96

handling, marking, shipping 91, 92, 96

possible determinations 93

See also *Bullet*; *Cartridge*

Amniotic fluid

as biohazard 266

Anatomical outlines 208, 209

Animals

poisoning 243

Anonymous Letter File 87

See *Documents*, *anonymous writing*

ANSI/NIST record 141

Arson 257-260

flammable liquids 257-260

scenes, evidence 257-260

suspects, evidence 257-260

See also *Flammable liquids*

ATF 160, 261, 262

Audio recordings 41-46

See *Video recordings*

Audio slate 42, 43, 44, 271

Automobile 52, 195 -203

See *Hit-and-run*; *Vehicle*

Automobiles—National Insurance Crime Bureau (*formerly: National Auto Theft Bureau*) 196

Automated Counterfeit ID Database 87

Autopsy *viii*, 4, 7

anatomical outlines 208, 209

autopsy kit 211, 271

bite mark recovery 206

body fluids and organs 208

clothing 208, 213

fingerprinting 144, 273

firearms evidence 210

hair 186, 210

identification of unknown 213-217

deceased 232

officer procedure 205

pathologist procedure 208

photography 22, 23, 27-28

poisoning - animal 232, 237, 243

poisoning - human 241

report 243, 283

sexual assault kit 270

toxicology samples 200, 232-234

wound area recovery 208, 210

x-ray dental records 217

x-rays 205, 208, 215, 217, 220-226

See also *Poisoning*; *Toxicology*

### B

Bile

samples 232, 233, 242

Biohazard

labels, use of 250, 265, 267, 268

shipment 200, 234

Bite marks

DNA, saliva recovery 39, 64, 75, 206

photography 17, 23, 28, 206

recovery at autopsy 206

Blasting caps 262

Blood

ante-mortem samples 233, 242

autopsy recovery 241-242

bullets, blood on 93

drug- screening and confirmation 235-236

hit-and-run, 199-200

identification of unknown deceased 217

packaging 234

sample collection 199-200

standard samples 70

toxicology 199-200

Bloodborne Pathogens

Exposure Control Plan 265

general guidelines 266

Hepatitis B 265, 266

HIV 265, 266

body fluids containing 266

other potentially infectious materials

- (OPIM) 266
  - protection against exposure 266-267
  - universal precautions 266
- Bloodstain Pattern Analysis 59-60, 282
- Body
  - DNA 61
  - See Autopsy; Deceased
- Body Bag 4, 200
  - body sheet 4
  - photography 200
- Bomb procedures 262
- Buccal swab 70, 74, 81-82, 211, 271, 275
- Building materials 163-166
  - at scene 163
  - suspect procedures 164-165
  - See also Glass; Metal; Paint; Wood
- Bullet
  - bearing fingerprints 91
  - detection by x-ray 145
  - handling, marking, shipping 5, 92-93
  - tissue, in 209
- Burglary 157-161
  - safe burglary 159-160
  - scene, procedure 158
  - suspect, procedure 158
  - See also Building materials
- C**
- Camera 2, 17-20, 23, 25, 29-38
  - See Photography
- Canine drug training 251
- Cardboard boxes 253
  - as packaging 6
- Cartridge
  - bearing fingerprints 96
  - handling, marking, shipping 92-94
  - possible determinations 93
- Casting 103
  - dental stone 107-112
  - marking of casts 118
  - Mikrosil 127
  - packaging of casts 118
  - snow print wax 107,110,112-116, 269
  - sulfur 112, 114-117, 270
  - what to cast 106
  - See also Dental stone; Impressions; Tool marks; Photography, footwear and tire
- Chain of custody 4, 12, 18, 20, 200, 237
- Checks
  - forgery 88
  - fracture match 191-192
- Clandestine drug laboratories v, viii, 245, 253-255, 278-279
- Clothing
  - air drying 207
  - autopsy recovery 208
  - fingerprinting and DNA 273
  - identification of unknown deceased, in 213-214
  - packaging
    - recovery and packaging 2, 200, 207-208
    - seminal stains 76-77
    - sexual offenses, in 274
    - shot or powder patterns in 95, 97
    - See also Fabric
- Computer generated printing 87-89
- Computer Evidence vi
- Condoms 64, 76,
- Controlled substances 245-255
  - See Drugs
- Courts
  - custodial chain, and 12
  - Laboratory services, and vi-x
- Crime Laboratories
  - areas of analysis v
  - contact information viii, 69
  - field services vii-viii
  - forensic units v
  - preliminary hearings x
  - providing technical support vii
  - requesting aid from vi-viii
  - service areas (map) iv, 278
  - tours of x
  - training programs ix
- Crime scene
  - Arson 257-260
  - burglary 157-158
  - chain of custody
  - fingerprints 120, 207
  - hit-and-run 198
  - maintaining crime scene log 1
  - poisoning 241-242
  - preserving the scene 1-2
  - processing 2-3, 77
  - videography 43-44
  - See also Crime scene sketch; Photography
- Crime scene sketch 47-55
  - computer based programs 56-57
  - documenting evidence recovery 211,
  - equipment 51-52
  - illustrating of 50, 55
  - labeling 55
  - latest technology 57
  - locating objects 53
  - rough 52
- Criminal damage to motor vehicles 195-196
- D**
- Deceased
  - body bag 4, 200
  - death investigation 238
  - hit-and-run, in 196
  - medical history 243,
  - poisoning 241-243
  - See also Autopsy; Deceased unknown
- Deceased unknown 143-147

- clothing 215-216
- external examination 213-214
- identification photographs 215-216
- internal examination 215-216
- personal effects 216-217
- Dental identification 219-226
  - examination procedures 119-221, 226
  - locating ante mortem records 224-225
  - NCIC 219
  - preparing postmortem records 221-223
- Dental stone 107-118, 222, 269
  - Bulk 108
  - dry powder method 109
  - mixing 108-109
  - premeasured 108
  - procedures 110-116
  - sand/soil, in 107
  - snow, in 112
  - snow print wax, with 112-113, 269
  - See also Casting; Footwear; Impressions; Tires*
- Diagram 158
  - See Crime scene sketch*
- Digital imaging *v.* 18-40
  - Admissibility 18
  - chain of custody 18
  - file formats 19
  - film resolution equivalents (table) 18
  - requirements for latent prints 19
  - storage 20-21
  - See also Photography*
- Division of Criminal Investigation
  - clandestine lab assistance *viii*, 245, 254, 278
  - computer evidence *vi*
- DNA
  - Definition 61
  - DNA buccal swab collection kit 74
  - commonly collected 64-65
  - collecting techniques 66-67
  - elimination samples 70-71
  - Local DNA Index System 71
  - mitochondrial DNA 62
  - nuclear DNA 62-63
  - packaging 4, 5, 6, 7, 68
  - preventing contamination 65-66
  - standard samples 70
  - storage of evidence 69
  - STR analysis 63
  - submission 68-69
  - submission guidelines 273-277
  - Y Chromosome DNA 62
- DNA Databank 79-86
  - buccal swab collection kit 81-82, 271
  - CODIS Architecture 80
  - Combined DNA Index System 79-80
  - fingerprints 83-84
  - State DNA Index System (SDIS) 80-81
- DNA samples
  - Biological Specimens Kit 270
  - Bloodstains 64, 200
  - cars 65
  - drug baggies 65
  - feces 64
  - fetal tissue 65, , 69
  - fired cartridge casings 276
  - food 65
  - hair 62, 64
  - saliva 39, 64, 75, 206, 276
  - semen stains 7, 64
  - Sexual Assault Collection Kit 64
  - tissue (skin cells) 64
  - touched items 63, 65, 66, 68, 70, 92, 276-277
  - urine 64, 69
  - vaginal secretions 64
  - vomit 67, 69-70
- Documents 87-90
  - Bank Robbery Note File 87
  - anonymous writings 90
  - care and marking 88
  - charred document preservation 87
  - computer generated 89
  - evidence, types of 90
  - examination 87
  - forgery 87
  - indentations on 88
  - liquid-soaked document preservation 87
  - packaging 88
  - photocopies 87
  - typewriting 87
  - See also Anonymous writing; Checks; Forgery; Handwriting; Typewriting*
- Drugs
  - body fluids, in 199-200
  - canine training 251
  - capsule/tablet identification 245, 249, 279
  - clandestine labs *v.* 253-255, 278
  - clandestine pharmaceuticals 278-279
  - color testing 250-251
  - ecstasy 250
  - fingerprints/DNA on packaging 253
  - fresh plant material dried 5, 277
  - illicit tablets 250
  - khat 247
  - liquids 249, 253
  - marijuana/THC 5, 245-246, 281
  - powders 7, 248, 253
  - pharmaceuticals 249, 278
  - precautions
  - pseudo drugs 251
  - repackaging of drugs 252-253
  - sample size for analysis 279
  - syringes 68, 241, 250, 267, 278, 282



- See also *Field drug testing kit; Clandestine drug laboratories*
- Duquenois-Levine color test 245  
 as probable cause 245  
 marijuana 245
- E**
- Ecstasy 250  
 See *Drugs, ecstasy and illicit tablets*
- Electronic imaging 17  
 See *Digital imaging*
- Electrostatic Dust Print Lifters 103  
 See *Impressions, dust; Footwear*
- Elimination standards (samples)  
 DNA 70-71  
 Fingerprints 277, 281
- Engine 25, 195  
 criminal damage to 195
- Envelopes  
 as packaging 6, 64, 66, 68, 84, 86  
 avoid use 164, 169, 176-177, 189  
 controlled substances for 253  
 kits 268, 270
- Evidence collection 3, 206, 268  
 Sexual Assault/Sexual Offenses 73, 75,  
 211, 270, 275
- Explosives v  
 assistance ATF 160, 261, 262  
 electric blasting caps 262  
 fireworks 261, 263  
 precautions 254, 262  
 safe burglary, in 160
- F**
- Fabric  
 air drying 182  
 impressions 23, 28, 182-183, 203  
 recovery and packaging 181 - 186  
 sexual offenses, recovery 77
- FBI  
 AFIS 141, 143, 150, 152, 153, 154, 155  
 DNA Databank 79  
 DNA Evidence and Standards 61, 63  
 Footwear and Tire 101, 103  
 Handbook of Forensic Services vii  
 Questioned Documents 87, 89
- Feces  
 as biohazard 266  
 DNA analysis 64
- Fibers  
 evidentiary value packaging 75 - 76,  
 122, 187, 203, 258  
 known sample 185-186  
 See also *Clothing; Fabric*
- Field Drug Testing Kit 279
- Field service v, vii - viii, ix  
 See *Crime laboratory, field service*
- Fingernails  
 identification of unknown deceased, in  
 scrapings 4, 75, 192, 214
- Fingerprints  
 arch pattern 142  
 AFIS 141-155  
 crime scene procedures 120-121  
 fingerprinting equipment 269  
 Laboratory results 129  
 latent prints 119-130  
 livescan 141-153  
 loop pattern 142  
 major case prints 131-139, 207  
 Next Generation Identification (NGI) system  
 141, 152, 281  
 obtaining good prints 119-130  
 palm prints 131-139  
 patent prints 119-120  
 , plastic prints 119-120  
 significance of 119  
 whorl pattern 142, 149  
 writer's palm 151  
 See also *Fingerprint processing*
- Fingerprint processing  
 backing cards 127, 269  
 fingerprint kit 269  
 gel lifters 127  
 gel tapes 127  
 lifts 126-127, 281  
 lifting method 128-129  
 marking lifts 129-130  
 nonporous item 119, 124  
 photography of 29, 120, 126, 127  
 porous items 119, 122-123, 125  
 powder cleaning techniques 125  
 powders, with 122, 124-125, 269  
 superglue, with 122-124  
 visual examination 122
- Fire  
 See *Arson*
- Firearms  
 handling, marking, shipping 91-97  
 possible determinations 91, 98-99  
 recovered from water/liquid 91-92  
 See also *Ammunition*
- Fireworks 261-263
- Flammable liquids  
 arson 257-260  
 clandestine labs 254  
 collection and packaging 4, 7-8  
 gasoline 8, 195-196, 257  
 unlawful to mail 196
- Fluids  
 See *Flammable liquids; Drugs, liquids*
- Footprints  
 See *Impressions; Footwear*
- Footwear  
 examinations 101-118  
 submission 101-102

- See also  *Casting; Impressions*
- Forgery  
See  *Documents, forgery*
- Fracture matching  
(table) 192  
See also  *specific kinds of evidence*
- G**
- Gasoline  
foreign materials in 195 - 196  
See also  *Flammable liquids*
- Gelatin lifters  
See  *Impressions, dust; Footwear*
- Glass  
chemical analysis of 168-169  
determining direction of force 169  
fracture matches 167-168, 191  
as packaging, 7  
collection and packaging 167  
hit-and-run, in 197-203  
known samples 167  
objects bearing fingerprints 119  
questioned glass 167  
recovery and packaging 68, 163-170
- Gun  
See  *Firearms*
- H**
- Hair  
arson 258  
autopsy recovery 186, 207-208  
collection of standards 185  
evidentiary value 62, 185, 214, 234  
DNA analysis 62, 64, 185  
head, standard sample 185-186  
identification of unknown 62  
deceased, in 62, 186, 214  
packaging 5, 186, 187, 207-208  
poisoning, in 234, 242  
pubic combings 64, 186  
pubic, standard sample 186  
recovery 75, 76, 77, 122, 158, 185-187,  
201, 203  
sexual offenses, recovery in 75, 76, 77,  
186  
toxicology sample, as 234
- Handwriting  
anonymous writings 87  
collected standards 87  
document collection procedure 88  
forgery 87, 151-152  
See also  *Checks; Documents*
- Hepatitis B Virus  
protection against exposure 265-267  
vaccination against 265-266
- Hit-and-run  
body fluids 199-200, 203  
clothing 181, 183, 197, 199, 203  
diagramming 198  
fingerprints 201  
glass recovery 167, 197, 198, 202  
impressions 183, 199, 203  
metal recovery 197, 198, 202  
paint recovery 175, 176, 197, 198, 202  
photography 195, 198, 202, 203  
plastic recovery 197, 198, 202  
scene procedure 197-203  
skid marks 195, 199  
towing 201  
vehicle procedure 201-203  
vehicle sketches 203  
victim (deceased) procedure 200-201  
victim (living) procedure 199-200
- HIV  
protection against exposure 265-267
- I**
- Impressions  
bite marks 23, 28, 38-39, 75, 206  
dust, in 3, 103-105, 120  
electrostatic dust print lifters 103-105  
fabric 23, 28, 182, 203  
footwear v., 2, 3, 23, 34-35, 101, 103-118,  
157, 269  
gelatin lifters 105-106  
hit-and-run 183, 199, 203  
photography 19, 23, 28, 32-39  
preserving 2, 88, 104  
procedure, general 103-118  
sand/soil, in 34, 103, 107, 110, 111-112,  
118  
snow, in 34, 103, 107, 110, 112-117, 269  
tire 35-37, 103-118, 269  
tire photography 35-37  
tool mark—See  *Tool marks*  
See also  *Casting*
- Indentations  
documents, on 88
- Inked prints  
See  *AFIS; Major Case Prints; Fingerprints*
- Intoxication, testing 227, 228, 230, 232, 233,  
235
- J**
- January 1, 2016 101, 103
- Jar(s) 7, 76-77, 186, 200, 209, 211, 231-  
233, 242, 268, 269, 278
- Jaw(s) 220-223, 226
- Jewelry Cleaner 248
- JPEG 19-20, 154
- Join 175, 191
- Joint(s) 131, 145, 150 266
- Junction 9, 16
- Juvenile 81
- K**
- Kidney  
autopsy recovery 232, 242
- Kits

- autopsy 271
- blood and urine 239
- biological specimens 270
- buccal swab 81-82, 271
- casting kits 269
- dental stone 269
- fingerprint processing 269
- general collection 268
- photographer's
- sexual assault collection 270
- studio equipment
- sulfur 279
- suspect evidence collection 270
- Knife
  - marks on bone 171
  - preserving cuts in clothing 181
- L**
- Laboratories, Crime
  - See *Crime Laboratory*,
- Laboratory of Hygiene, State 237,239,280
- Latent prints 119-130
  - Submission Guidelines 252, 281-282
  - See *Fingerprints; Fingerprint processing, Automated Fingerprint Identification System (AFIS)*
- Law Enforcement Bulletin ix
- Leather
  - packaging 7, 182
- Liquids
  - See *Drugs, liquids; Flammable liquids*
- Liver
  - Poisoning 242
  - Specimen collection 232-233
- LSD 236
  - tear match 191-192
- Lungs 234, 266
- M**
- Machine guns
  - See *Firearms*
- Major case prints
  - ink method 135-139
  - powder & tape method 131-134
  - See also *Fingerprints; AFIS*
- Manila envelopes
  - as packaging 6, 268
- Marijuana
  - Description 245
  - Detection 229
  - health risks 246
  - packaging 5, 246
  - possession cases 245
- Medication 243
  - See *Drugs, pharmaceuticals*
- Metal
  - autopsy recovery 205
  - detection by x-ray 205
  - evidentiary value
  - fabric weave impressions on 203
  - fracture match 191-192, 202
  - hit-and-run, in 176, 197-198
  - immersed in liquid 91-92
  - recovery of samples 179
- Metal cans 278
  - as packaging 5, 7-8, 253, 258, 278
- Mikrosil 127
  - See *Casting, Mikrosil ; Tool marks*
- Mitochondrial DNA 62-63
- Mushrooms
  - See *Psilocybe mushrooms*
- N**
- Narcotics
  - See *Drugs*
- National Automobile Theft Bureau
  - See *National Insurance Crime Bureau*
- National Insurance Crime Bureau 196
- NCIC 219
  - dental identification, and
  - Next Generation Identification (NGI) system
  - See *Fingerprints*
- Nitroglycerine 160, 262
- Nuclear DNA 62
- O**
- Organs, body 208, 216, 232
  - See *individual organs*
- P**
- Packaging
  - ammunition 91-99
  - arson investigations, clothing
  - arson samples
  - autopsy samples
  - biohazard samples
  - blood samples 7,
  - body fluids 199, 208
  - buccal swabs 70
  - building materials 163-166
  - cardboard boxes 6, 253
  - charred documents 87
  - clothing 4-5, 7, 64, 76, 181-183
  - documents 87- 89
  - evidence, generally 1-11
  - fabrics 181-183
  - fibers 185-187
  - firearms 91
  - flammable liquids 7
  - glass samples 169
  - glass vials and jars 7
  - hair 5, 185-187
  - latent fingerprint on
  - leather 7, 182
  - liquids 7
  - marijuana 5
  - metal cans 5, 8
  - packaging checklist 16
  - paint samples 175-176

- paper 4-7
- plant material 5
- plastic 5, 7
- saliva samples 39, 75, 206
- separating items 68, 76, 77, 97, 118, 158, 163-165, 168-169, 176, 181, 189, 193, 206-207, 246, 253, 273, 277, 281
- sexual assault evidence 73, 270
- slide boxes 6
- swabs 66, 68, 73, 75, 77
- syringes 68
- tissue specimens 209
- tools 172, 259
- toxicology specimens 234
- urine samples 231
- wood chips from burglaries 189
- Paint
  - as evidence in burglaries 175-177
  - as trace evidence in arson 258
  - evidentiary value
  - fabric-weave impressions, in 203
  - fabrics, on 181
  - fracture matches
  - hit-and-run, in 175-176, 197
  - packaging 177
  - recovery 175-177
  - stolen vehicles 196
  - tool marks, and 176
- Palm prints
  - See *Fingerprints, palm prints, writer's palm; Fingerprint processing; Major Case Prints*
- Paper
  - handwriting standards, in 87
- Paper bags
  - as packaging 5, 66, 76, 179, 182, 186,
- Pathologist
  - autopsy procedures, general 205-211
  - autopsy procedures, poisoning 234, 241-243
  - role in identification of unknown 213-217
    - deceased 208-211
- PCP 236, 249
- Perforation matching
  - (table) 192
- Pericardial fluid
  - as biohazard 266
- Peripheral blood 232, 233
- Peritoneal fluid
  - as biohazard 266
- Personal protective equipment
  - Booties 2-3, 266
  - Gloves 2-3, 65-66, 266
  - Masks 65, 248, 266
- Perspiration (sweat)
  - as biohazard 266
  - DNA analysis 64
- fingerprints 144
- Peyote 247
- Pharmaceuticals
  - See *Drugs, pharmaceuticals* 249, 278
- Photocopies and documents 87-89
- Photography
  - Autopsy 22-23, 27-28, 206-208
  - bite mark 17, 23, 28, 29, 38-40, 75, 206
  - bloodstain patterns 60, 283
  - building, exterior 17, 22, 42
  - building, interior 17, 22, 42
  - burglary 158
  - casting, prior to 103, 106, 111, 112
  - continuity of images 21
  - crime scene, at 3, 36, 77, 158, 257
  - electronic flash 29, 33, 34
  - evidentiary value 23, 29
  - filling frame with image 30, 31, 35, 36, 38, 126
  - fingerprints 126, 127
  - footwear impressions 34-35
  - forensic, general 17-40
  - "four views" of rooms 21
  - hit-and-run 198
  - impressions 35-36
  - lenses, macro 126
  - lighting 24, 25, 31, 32-33, 35, 36, 38
  - motor vehicle accidents 198
  - photo log 23, 271
  - recommended equipment 29, 40
  - scaling 29, 31, 34, 207, 208
  - scaling, required equipment 29
  - services offered by Laboratory 17
  - procedures 18-21
  - suspect 21
  - tire impressions 35-37, 103
  - tool marks 158, 174
  - tripod 25, 29, 31, 34, 35, 38, 57, 126
  - unknown deceased 215
  - vehicles, initial record 195, 196, 198, 200, 202, 203
  - victim 215
  - See also *Digital imaging*
- Physician
  - blood samples 230
  - poisoning procedures 241, 243
  - sexual offense procedures 73
  - See also *Pathologist; Veterinarian Physicians Desk Reference*
- Pipette
  - liquid transfer, and 7
- Plaster of Paris 172
  - See *Dental stone*
- Plastic
  - as evidence 98, 123, 191, 281
  - as fire debris 259
  - as packaging 231, 248

- cable ties 181-182, 271
- hit-and-run 197-199
- trace evidence 175, 197
- Plastic bags
  - as packaging 169, 182, 186, 231, 246, 280
  - fingerprints 123
- Plastic impressions
  - fingerprints 119, 120
- Pleural fluid
  - as biohazard 266
- Poisoning, animal 243
- Poisoning, human
  - autopsy procedure 241
  - medical information 243
  - scene procedure 241
  - supplementary information 242-243
  - victim procedure 241-242
  - See also *Autopsy*; *Toxicology*
- Poppies, opium 247
- Powder
  - drugs, sample size for analysis 248
  - fingerprint 105, 122-127, 131-139, 269
  - gunshot, in tissue 93, 95, 97, 209
  - packaging considerations 5, 252-253
- Powder pattern
  - in clothing 95, 97
  - possible determinations 91, 93
- Prescriptions
  - See *Drugs, pharmaceuticals*
- Pretrial conference *x*
- Printing, hand 13, 87
- Prints
  - See *Fingerprints*; *Impressions*; *footwear*; and *Tire*
- Psilocybin mushrooms 247
  - packaging 5
- Pubic hair
  - See *Hair, pubic combings and standards*
- Q**
- Quality
  - Quality assurance
    - bloodstain analysis, in 60
    - DNA 61
    - DNA Databank 79
    - index 71
- R**
- Rape
  - See *Sexual offenses*
- Reports
  - stand in lieu of appearance *x*
  - at preliminary hearings *v x*
- Restoring serial numbers 91, 196
- Retaining frame (form)
  - casting impressions 107, 110, 114
- Revolver
  - handling, marking, shipping 92-97
  - possible determinations 93
- Rifle
  - handling, marking, shipping 92-97
  - possible determinations 93
- S**
- Safes
  - burglary 159
  - combination lock nomenclature 160
  - nomenclature 159
  - See also *Burglary*
- Saliva
  - collected from 39, 64, 75, 206
  - collection procedure 66-67
  - See also *Bite marks*
- Sand
  - casting impressions in 107-112
  - photographing impressions in 32-37
  - vehicle engines, in 195-196
  - See also *Soil*
- Sawdust
  - See *Wood*
- Sealing evidence
  - heat sealing 11-12, 16, 253
  - staples, and use of tamper-evident tape 10
  - tamper-evident adhesive strip 10
  - tape 9
- Seminal fluid
  - as biohazard 266
- Seminal stains
  - recovery 76
  - sexual offenses, in 76-77
- Serial number
  - restoration *v*, 91, 196
- Service Areas *iv*
- Sexual offenses
  - autopsy procedures 210
  - Biological Specimens Kit 73, 270
  - bite marks—See *Bite marks*
  - buccal swab 74
  - blood samples 229-230
  - clothing 76
  - condoms 76-77
  - evidence collection 64, 68-69, 73-77
  - fabrics as evidence 77, 181-183
  - finger nail scraping 75
  - finger swab 75
  - pubic hair combings 186
  - pubic hair standards 186
  - saliva samples 64,75
  - scene processing 1-4, 77
  - semen stains 64,77
  - toxicology specimens 7, 228, 236, 238
  - trace evidence 76
  - Sexual Assault Evidence Collection Kit 73, 270
  - sexual offenses, unusual 77

- Shoes
  - arson investigations 259
  - burglary investigations 164
  - glass fragments adhering to 167
  - packaging 182
  - sawdust adhering to 189
  - wood fragments adhering to 189
  - See also Impressions; Prints, footwear and tire
- Shot patterns
  - in tissue 209-210
- Shotgun
  - handling, marking, shipping 92-97
  - possible determinations 93
- Skid marks 195, 199
- Slide box, as packaging 6, 97
- Snow, impressions in 112-117
- Sodium fluoride 200, 211, 230
- Soil
  - arson, in 258
  - casting impressions in 107-112
  - footwear, and 103, 107, 110
  - photographing impressions in 32-37
- Spleen 232-233
- Standards
  - DNA 70, 74, 81, 271
  - blood 7, 69-70, 199-200, 227-228, 230-233
  - documents 87
  - fibers 185-186
  - hair 185-186
  - handwriting 87
  - paint 175-177
- State Laboratory of Hygiene
  - See *Toxicology*
- Steroids 249
- Stomach contents
  - autopsy recovery 216, 233, 242
- STR analysis 63-64
- Sulfur
  - casting 114-117, 270
  - safety concerns 114
  - See also *Casting*
- Synovial fluid
  - as biohazard 266
- Syringes
  - as biohazard 250, 267
  - packaging 68, 250, 278
- Synthetic cannabinoids 247
- T**
- Tablets 7, 245, 249-250, 278-279
  - See *Drugs, illicit tablets and pharmaceuticals*
- Tear matching
  - (table) 191-192
- Telephone numbers (or websites)
  - computer seizure, for vi
  - crime laboratories iii
  - FBI fingerprint database processing center (AFIS pg) 141-155
  - independent toxicology labs, for 239
  - State Lab of Hygiene 238-239
  - WI Veterinary Diagnostic Lab 237, 239, 243
- Tissue
  - autopsy recovery 208-210, 241-242
  - DNA analysis 61, 64-65
  - finger nail scrapings, in 64, 75
  - shot or powder patterns in 95, 97
  - See also *individual organs*
- Tires
  - examinations 101-102
  - hit-and-run investigations 202
  - See also *Casting; Impressions; Skid marks*
- Tool marks
  - burglary, in 157, 158, 161
  - casting 172
  - evidentiary value 171
  - Mikrosil 172
  - paint samples, and 176
  - photography 28
  - preservation 172
  - recovery 171-172
  - types and location 171
- Tools
  - arson investigation, and 259
  - burglary investigations, in 157, 158, 161
  - evidentiary value 171
  - fragments 161
  - packaging 172
  - trace evidence, and 194, 196, 165, 171, 172
  - types of investigations 171
  - See also *Tool marks*
- Touch DNA 65, 276-277
- Tours vii
- Towing
  - hit-and-run vehicle 201
- Toxicology
  - animal poisoning, in 243
  - autopsy specimens 211, 232, 241, 243
  - bile samples 232, 233, 242
  - blood alcohol 228, 230, 233, 235
  - blood samples 227, 228, 230
  - collection, living individuals 230-231
  - collection, deceased 232-233
  - contact information 238-239
  - detection periods 229 (table)
  - drug screening 235-236
  - GHB 236, 249, 250
  - hair samples 234, 242
  - independent toxicology labs 239
  - immunoassay 235
  - kits 239

- liver samples 232, 233, 242
- lungs 234
- peripheral blood 232, 233, 242
- postmortem redistribution 228, 232, 233
- samples, where to submit 237-239
- sexual offenses, in 228, 236
- specimen preservation 234
- specimens, in lieu of blood 233-234
- spleen samples 233
- State Laboratory of Hygiene 237-239
- stomach contents 233, 242
- storage and shipping 234
- submissions: Hygiene vs. Crime Lab 238  
(table)
- testing 235-236
- urine samples 228, 231, 232
- vitreous humor 232, 242
- See also *Poisoning; Autopsy*
- Training programs *vi*,
- Transmittal of Criminal Evidence Form
  - checklist for use 16
  - electronic version 14
  - general 14-16
- Typewriting
  - submittal procedures 87
- U**
- Universal precautions 3, 266
- Urine
  - as biohazard 266
  - clothing, in 182
  - DNA analysis 64
  - drugs and alcohol 227-232, 235
  - hit-and-run, in 200
  - human, recovery 270
  - packaging 69, 182, 200, 279-280
  - poisoning, in 241-242
  - toxicology sample 227-232, 235, 239,  
279-280
  - sample storage 69
- V**
- Vaginal secretions
  - as biohazard 266
  - DNA analysis 64
- Vehicle
  - arson, in 259-260
  - burglary, used in 158
  - criminal damage to 171, 195-196
  - fiber transfer 187, 203
  - fingerprints 201
  - fractured parts from 167-168, 192, 198,  
202
  - hit-and-run, in 167, 175-176, 181-182,  
197-203
  - impoundment 195
  - moving 201
  - note in area of crime scene 1
  - paint samples 175-176, 198, 202
  - physical impressions left by 101, 182, 199,  
203
  - repainted
  - sketches/photography of 24-27, 50, 99,  
198, 203
  - skid damage 199, 202
  - stolen 196-197
  - stripped parts, matching 196
  - submission of
  - trace evidence on operating pedals
  - See also *Hit-and-run Impressions, footwear  
and tire; Tires*
- Veterinarian
  - poisoning procedure 243
- Victim
  - photography 38-40, 215
  - recovery of body fluids and  
tissue from 64, 73-76
- Video taping, Video tapes
  - authentication 42
  - duplicating 41, 44, 45
  - not recommended as exclusive  
recording medium 43
  - procedures 43-44
  - submitting
  - usefulness 41
- Video recordings
  - audio slate 42-44
  - crime scenes, of 43-44
  - criminal investigations, in 3, 17, 41-46, 60
  - interviews and interrogations, of 44
  - labeling 42
  - Laboratory examinations of 41-42
  - sealing 45
  - uses of 41
  - viewing 45
  - write protecting 45
- Vitreous humor
  - autopsy recovery 232-233
- Vomit
  - as biohazard 266
  - DNA analysis 65, 67, 69
- W**
- Water
  - dilution of urine samples 231
  - distilled, used in kits 268, 269
  - drying wet cloth or clothing 182, 199, 206,  
207
  - evidence packaging, and 4, 68
  - metal immersed in 91-92
  - mixing dental stone, in 108-110
  - soil, in 111-112
- Wood
  - evidentiary value 189
  - sawdust adhering to shoes 189
- Wound areas
  - autopsy procedure 207-210

autopsy recovery 208, 210  
photography at autopsy 28, 207

**X**

X-rays  
autopsy 217  
dental identification 217, 220  
records, as 224-226  
to locate dislodged teeth or fragments 220  
unknown deceased identification 215

**Y**

Y chromosome DNA  
STR testing 62-63

**Z**

Zip ties 271  
Zip lock or zip top bags 108, 282  
Zoom(s) 43





**EVIDENCE**

## CERTIFICATION OF PROPOSED GUIDANCE DOCUMENT

I have reviewed this guidance document or proposed guidance document and I certify that it complies with sections 227.10 and 227.11 of the Wisconsin Statutes. I further certify that the guidance document or proposed guidance document contains no standard, requirement, or threshold that is not explicitly permitted by a statute or a rule that has been lawfully promulgated. I further certify that the guidance document or proposed guidance document contains no standard, requirement, or threshold that is more restrictive than a standard, requirement, or threshold contained in the Wisconsin Statutes.

On behalf of the Attorney General

A handwritten signature in blue ink, appearing to read 'Charlotte Gibson', is written over a horizontal line.

CHARLOTTE GIBSON

Division of Legal Services Administrator